

| Parts List | | | | Parts List | | | |
|------------|-----|-----------------|---|------------|-----|-------------------------|---|
| ITEM | QTY | PART NUMBER | DESCRIPTION | ITEM | QTY | PART NUMBER | DESCRIPTION |
| 1 | 1 | 026-0185-00 | Paddle Blower Outer Plate | 17 | 2 | 032-5000-00 | 1/2" Oil Impregnated Bushing |
| 2 | 1 | 039-0159-00 | Paddle Blower Cover BRK | 18 | 2 | 019-8054-00 | .505 Nylon Spacer |
| 3 | 1 | 026-0182-00 | Paddle Blower Cover plate | 19 | 1 | 033-6001-00 | 4 3/4 Idler Pulley - ABFI-76 |
| 4 | 1 | 039-0160-00 | Paddle fan weldment | 20 | 1 | 033-4900-00 | 4x1 v- pulley |
| 5 | 1 | 088-1894-00 | Paddle Blower Weldment | 21 | 2 | 7/16-20x1" hex bolt | |
| 6 | 2 | 088-4067-00 | Flanged Bearing for 1 3/16" shaft | 22 | 3 | 1/2-13 x 1.75" hex bolt | |
| 7 | 1 | 033-5034-00 | 4 3/4" Motor Pulley | 23 | 3 | 013-8050-00 | 1/2-13 NYLON INSERT FLANGE LOCKNUT ZINC |
| 8 | 1 | 039-0158-00 | Paddle Blower tensorer arm | 25 | 4 | 018-8052-00 | 1/4" x 3/4" Hex Bolt |
| 9 | 1 | 042-6030-00 | 1/4" x 1" Key | 26 | 4 | 013-2050-00 | 1/4-20 Hex flang lock nut |
| 10 | 1 | 030-0050-00 | 5/16 Set Screw | 27 | 1 | 034-0090-00 | 3" Extension Spring |
| 11 | 2 | 019-8053-00 | 7/16" Lock Washer | 42 | 1 | 034-0090-00 | 3" spring with closed loop ends |
| 12 | 2 | 019-6020-00 | 1/2" Belleville Washer | 43 | 2 | 019-8040-00 | 1/4-20 X 3/4 CARRIAGE BOLT (GR.5) ZINC |
| 13 | 4 | 018-5043-00 | 3/8" x 1 1/4" Carriage Bolt | 44 | 2 | 013-8051-00 | 1/4-20 WING NUT FORGED (TYPE A) LIGHT SERIES ZINC |
| 14 | 4 | 013-5202-00 | 3/8" Nylock Flange Nut | 45 | 1 | 018-4007-00 | 1/4-20 X 1 HEX CAP SCREW (GR.5) ZINC |
| 15 | 17 | 030-7041-00_Old | 1/4-20x1/2 HWH Bolt Slot | 46 | 1 | 018-0011-00 | 1/4-20 X 2 HEX CAP SCREW (GR.5) ZINC |
| 16 | 2 | 025-7036-00 | 1/2 Solid Shaft Collar (W/1 Set Screw) Zinc | 47 | 4 | 013-9001-00 | 1/4-20 HEX SERRATED FLANGE NUT HARD/ZINC |

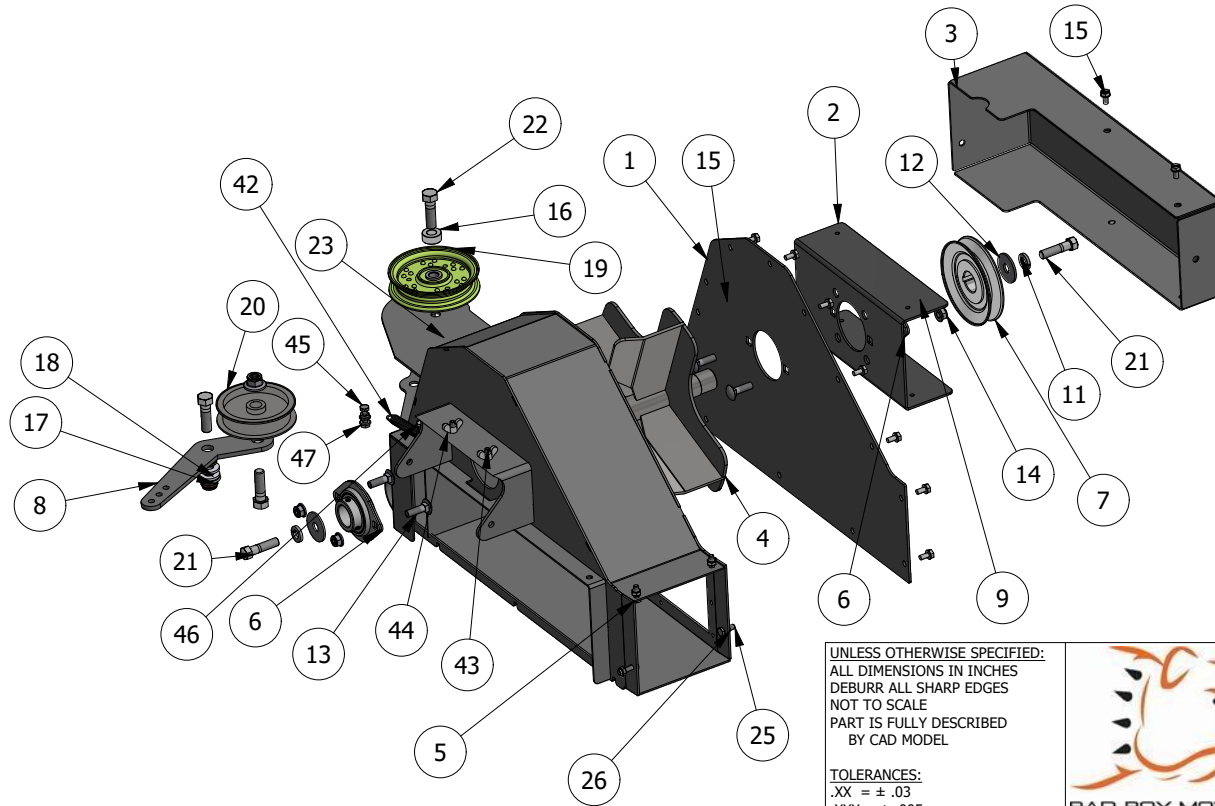

Bolt Kit # 088-1893-01

UNLESS OTHERWISE SPECIFIED:
 ALL DIMENSIONS IN INCHES
 DEBURR ALL SHARP EDGES
 NOT TO SCALE
 PART IS FULLY DESCRIBED
 BY CAD MODEL

TOLERANCES:
 .XX = ± .03
 .XXX = ± .005
 .XXXX = ± .0005
 ANGULAR = ± 1°

Material:
 Coating:

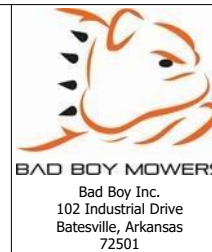

Scale: NTS
 Sheet Number
1 OF 1
 Revision:

Part Number
088-1893-00
 Description
Paddle Blower Assembly

| REV | ECN NUMBER | DESCRIPTION | DATE | APPROVED |
|------------------|------------|---|------|----------|
| | | Preliminary: For Quoting And Samples Only | | |
| REVISION HISTORY | | | | |