



**PLEASE REFER TO THIS MANUAL BEFORE YOU USE THE PRODUCT. ALWAYS PLACE THIS MANUAL NEAR THE PRODUCT AND NOTE THAT THIS MANUAL SHOULD BE TRANSFERRED TO OTHERS IF YOU TRANSFER THE PRODUCT TO THEM.**

# PREFACE

This operator's manual contains handling tips and precautions for safe operation of your a **BAD BOY 5045(CS, CH, S, H) / 5055(CS, CH, S, H)** tractor. Read it carefully before you operate your tractor and make sure that you have a full understanding of this manual. This will ensure correct operation and to keep the tractor optimum condition.

After reading the manual, keep it close to the tractor for immediate reference. When you loan your tractor to someone else, loan the manual as well.

In case the manual is lost or damaged, please contact your local authorized dealer for a copy. Some parts of this product may have been changed for the improvement of quality or for safety reasons, in which case the photographs or drawings of the parts in this booklet may not be the same as the actual parts installed on this product. If you find anything in this manual unclear or need further explanation, please contact your authorized dealer.

※ Regarding the purpose of this machine

Do not modify the machine or try to do the job which is beyond purpose of this machine. Otherwise it may cause the warranty cancellation. (Refer to warranty statement for detail)

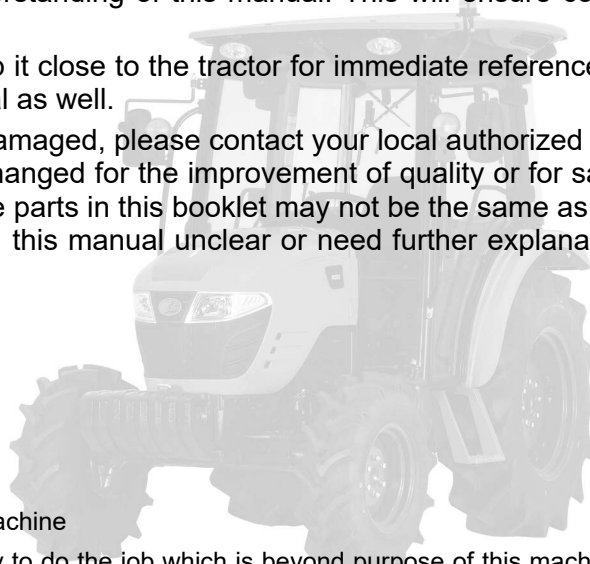



# TABLE OF CONTENTS

## ***SECTION***

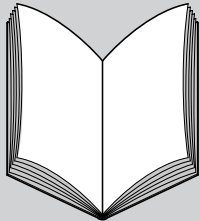





● FOR SAFE OPERATION .....	1
● REGARDING WARRANTY SUPPORT .....	2
● SPECIFICATION .....	3
● DESCRIPTION OF OPERATING SYSTEM .....	4
● CONTROLS AND COMPONENTS .....	5
● PERIODIC CHECKS AND MAINTENANCE .....	6
● DIAGNOSIS AND TROUBLE SHOOTINGS.....	7
● STORAGE AND DISPOSAL .....	8
● ENGINES EMISSION WARRANTY .....	9



# SAFETY AND VEHICLE DAMAGE WARNING

This manual includes information titled as **DANGER, WARNING, CAUTION, IMPORTANT**. These safety marks stand for the safety precaution so follow the instruction with special attention:

 <b>DANGER</b>	This symbol indicates that a condition may result in harm, fatal injury or death to you or other persons if this instruction is ignored.
 <b>WARNING</b>	This symbol indicates that a condition may result in harm, serious injury or death to you or other persons if this instruction is ignored.
 <b>CAUTION</b>	This symbol indicates that a condition may result in damage to your vehicle or its equipment if this instruction is ignored. Also this symbol alerts the operator's unstable operation.
 <b>IMPORTANT</b>	This symbol indicates emphasis on notable characteristics of working procedures, and information about technology for easier operation.
<b>NOTE</b>	This instruction is to give additional description to operator so that he/she can operate the machine more effectively.

This manual includes "Very important safety tips for safe operation" as a chapter. Be sure to read this chapter before initial operation.

# SYMBOL MARKS OF CONTROLLER

This manual includes symbol marks of the controller to simplify operations for maneuverability and maintenance. These meanings are as below, so carefully read it for a proper function.



Left Turn signal



PTO



Engine Oil Pressure



Right Turn signal



Parking Brake



Battery Charging Warning



High Beam



Pre-heat



DPF

## **“USE AND DISPOSAL” POLICY CONCERNED WITH ENVIRONMENT PRESERVATION**

We try our best to preserve the environment, and are always concerned about our environmental impact at each step of planning, development, production, distribution, use and disposal of products, and for our over-all operations through an “environmentally friendly” management system. We comply with international environmental regulations, environmental regulations designated by country and local authorities and other requirements with which we are in agreement, and we work towards the prevention of environmental pollution and the conservation of resources. We provide environmental education and have an awareness campaign to raise environmental awareness among all our employees and members of the supporting companies.

We introduce the “Use and Disposal” policy concerned with environment preservation as follows.

1. Please read the operator’s manual though for global environment protection. Overload on the machine shortens the product life and increases the harmful exhaust gas which cause air pollution due to the incomplete combustion.
2. When replacing various fluids (for engine, transmission, hydraulics, etc.) by yourself, don’t dispose the used oil to anywhere not recommended. It can pollute the ground and water. Please contact your local dealer to dispose it legally.
3. Observe the operator’s manual and store or dispose the waste product properly. Rust, oil, etc leaked from waste product improperly stored can pollute the ground and water. Accordingly for a waste product disposal, contact the necessarily “approved waste collection and recycling facility” to discard the used materials legally.

# 1. FOR SAFE OPERATION

<b>SAFETY PRECAUTIONS .....</b>	<b>1-2</b>
<b>BEFORE USING THE MACHINE .....</b>	<b>1-2</b>
BEFORE WORKING.....	1-11
WHILE WORKING .....	1-16
AFTER USING THE MACHINE .....	1-17
PRECAUTION FOR PROLONGED STORAGE .....	1-21
OTHER.....	1-23
<b>DECAL CABIN.....</b>	<b>1-34</b>
DECAL ROPS.....	1-36
CAUTIONS FOR DECAL MAINTENANCE .....	1-38



## SAFETY PRECAUTIONS

If the instructions in this chapter are ignored, it may cause a machine failure, a fatal accident with injury or death.

For further detailed information, refer to each chapter.

### NOTE

- Please understand that some of the figures or contents in this manual may not match with your own machine due to the product variation.
- This tractor is not designed for road driving. Please use a truck to move this machine on the public roads.

## BEFORE USING THE MACHINE

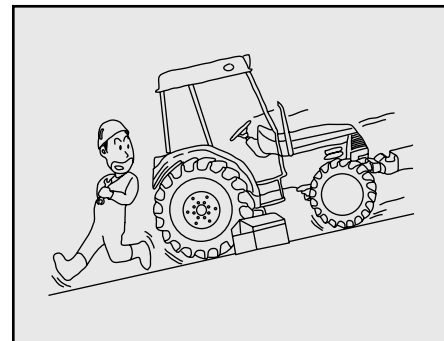
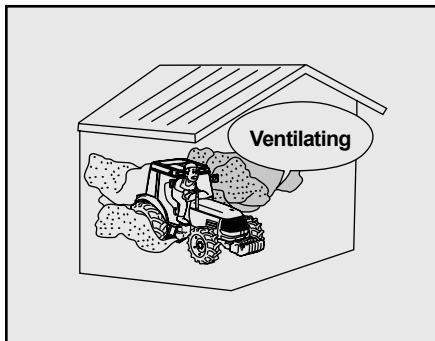

### WARNING

Beware of exhaust gas;

- Running the engine, repairing (tightening) any painted part or grinding any painted area should be performed only in a well-ventilated area.

If this instruction is ignored, the exhaust gas or dust can cause intoxication and lead to fatal consequences.



### WARNING

Wide and flat enough area;

- Inspect or repair the tractor on a wide and flat area.

If this instruction is ignored, an unexpected accident may occur, such as overturning of the tractor.

**⚠ WARNING**

Clean and arranged place;

- Do not mess the place by dust, mud, oil, or parts

If this instruction is ignored, an unexpected accident may occur.

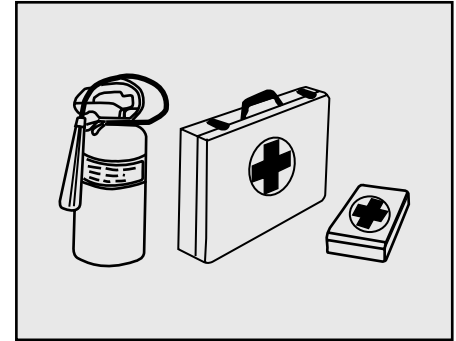
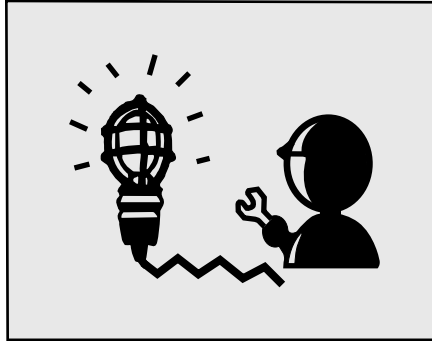
**⚠ WARNING**

Carry out maintenance in a well-lit place;

- Make sure work area is properly lighted.
- Use safety work lights with protective covering when working inside or under the machine.

If this instruction is ignored, an unexpected accident may occur, possibly fire or explosion.

**⚠ WARNING**

Prepare for emergencies;

- Keep a first aid kit and fire extinguisher handy at all times while operating machine.

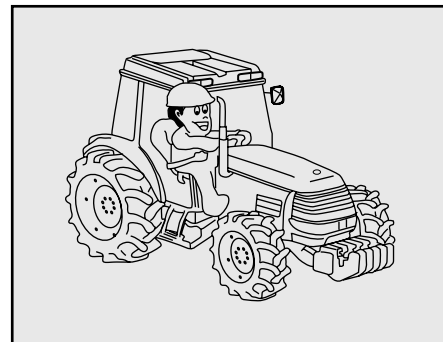
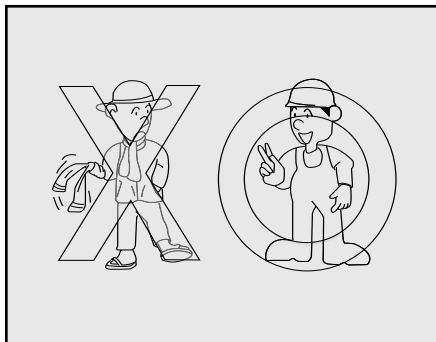
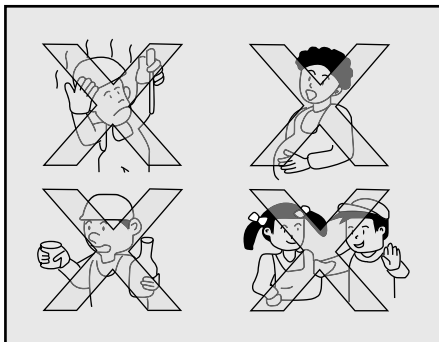

**! WARNING**

Do not drive if you are;

- Unable to concentrate because of fatigue, under treatment of medicine.
- Under the influence of alcohol
- Pregnant
- Under the age of 18

**! WARNING**

Wear properly for the job;

- Hair band, loose clothing is not allowed. Wear tight clothes, work hat, and work shoes which have rough bottoms against slippery surface.

If this instruction is ignored, you will be exposed to a risk of being entangled, slipping, or falling.

**! WARNING**

Use only recommended implements;

- Be sure to use only implements which are recommended by manufacturer.

If this instruction is ignored, an unexpected accident may occur or tractor may not perform properly.

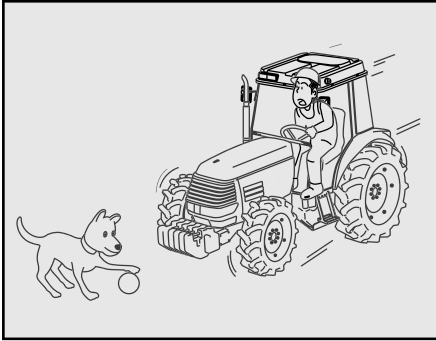

**⚠ WARNING**

Start the machine slowly after reminding bystander;

- Start the engine after reminding bystanders of your intention. Do not start the machine abruptly.

If this instruction is ignored, unexpected accident or injury can happen.

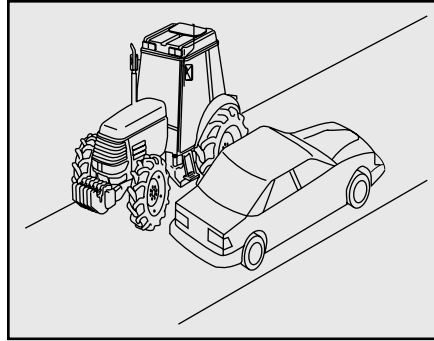

**⚠ WARNING**

Pay attention to the shoulder of the road;

- When moving along the unpaved road with ditches or slanted sides, pay attention to the shoulders.

If this instruction is ignored, there is a risk of falling over.

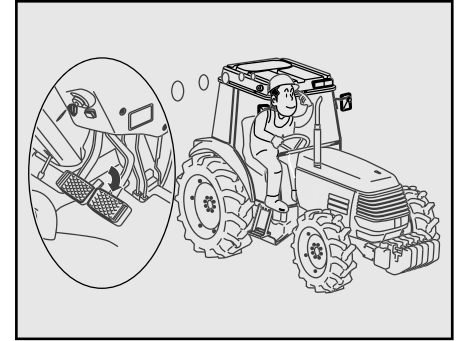

**⚠ WARNING**

Interlock the brake pedals (left and right) when driving on a road;

- Make sure to interlock the brake pedals (left and right) when driving on a road

If this instruction is ignored, there is a risk of abrupt turning or overturning due to one-sided braking.



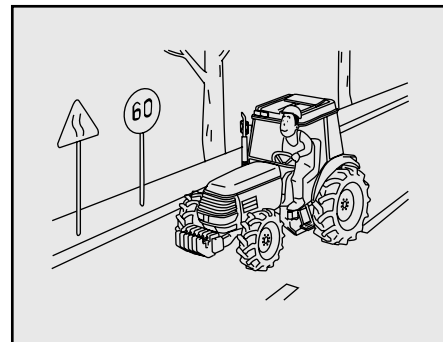
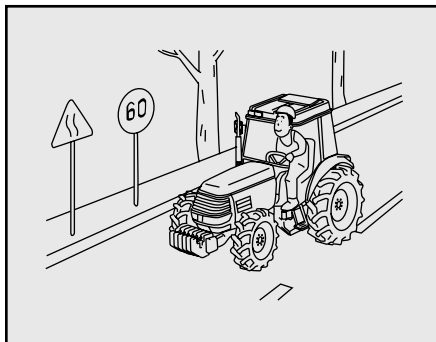
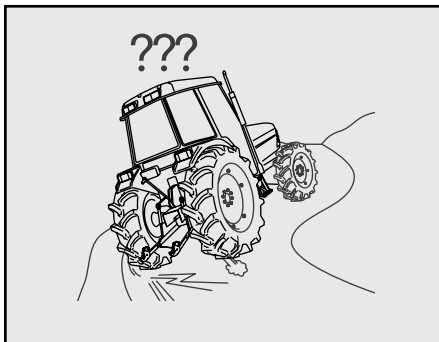

 **WARNING**

Avoid rapid starting, braking, turning, and excessive speed;

- Start and stop the tractor slowly. Reduce engine speed when making a turn and driving on hilly or curved roads.

If this instruction is ignored, there is a risk of overturning or damage to the machine.

 **WARNING**

Observe traffic regulations and drive safely;

- When driving on the road, observe the traffic regulations and wear a hard hat and seat belt.

If this instruction is ignored, there is a risk of accident or injury.

 **WARNING**

Observe traffic regulations when driving on a road safely;

- If the machine is broke down and stopped on the road, move the machine to a safe place out of the road.

If this instruction is ignored, there is a risk of accident or injury.

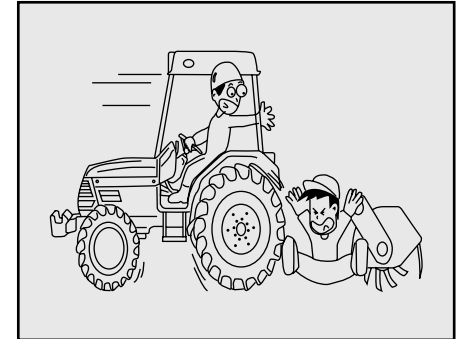
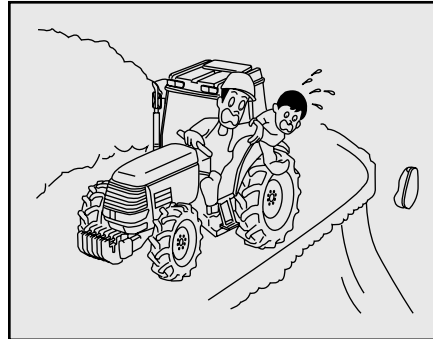
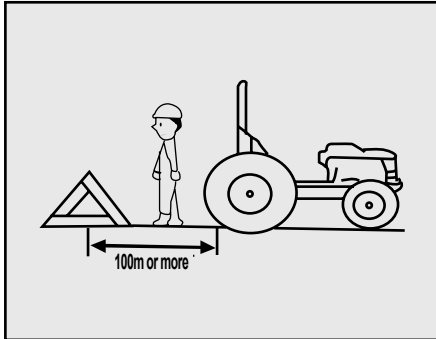

**! WARNING**

Put machine shut down sign if the machine is stopped on the road;

- If the tractor is stopped on the road due to the machine failure, put the machine shut down sign (Emergency triangle reflex reflector) at least 100~200 yards before failed machine in accordance with local traffic laws.

If this instruction is ignored, the machine can be hit by a car and cause a traffic accident with injury or death.

**! WARNING**

Only driver should be aboard the tractor while in operation;

- This tractor is designed to allow only one operator. The driver must not allow anyone else to get on the tractor.
- Especially never allow children on the machine while in use.

If this instruction is ignored, an unexpected accident may occur.

**! WARNING**

Do not allow anyone near while operating the tractor or implement;

- When engaging or disengaging the implement by moving the tractor, make sure that no one is around the tractor or between the implement and the tractor.

If this instruction is ignored, there is a risk of accident or injury.

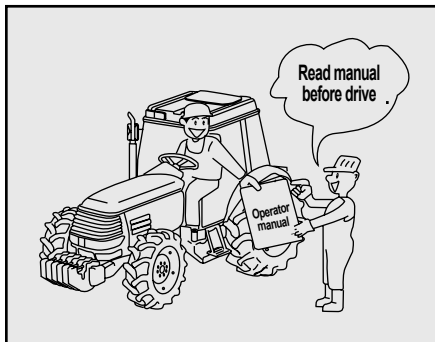
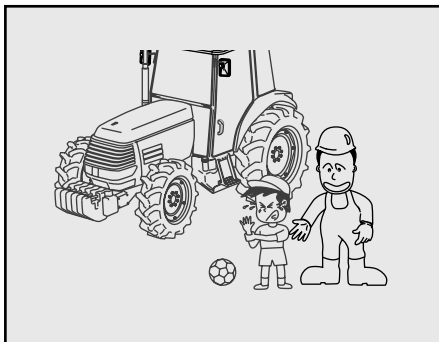

 **WARNING**

Precautions for children;

- Fully warn the children and keep them away from the tractor at all times.

If this instruction is ignored, unexpected accident of injury can happen.

 **WARNING**

Properly train anyone operating;

- Explain the handling tips in detail and make sure the driver reads the Manual before driving.

If this instruction is ignored, there is a risk of death, serious injury, or damage to tractor.

 **WARNING**

Use Pesticides safely;

- Careless use of agricultural chemicals such as disinfectants, herbicide, pesticides, rat poison, and fertilizer can be harmful to environment and human body. Be sure to observe all relevant regulation and instructions to use the agricultural chemicals efficiently and safely. Then it may prevent injury or accident.

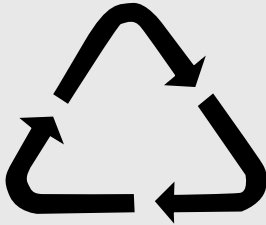
 **WARNING**

Observe all relevant regulations for disposal;

- Be sure to observe all relevant regulations when you dispose of the engine oil, transmission oil, fuel, coolant, filters and battery.
- Never dispose the used oil directly to the river or drainage, follow legal procedures.

 **WARNING**

Observe all relevant regulations for disposal;

- Careless disposal of waste product can be harmful to environment and ecosystem.
- When draining the fuel and oil, use a proper container that is not leaking, not food or beverage containers to prevent from drinking. Do not bury the waste product in the ground or dispose to drainage.

 **WARNING**

No smoking or open flame when fueling;

- Do not smoke or use match or lighter while refueling.

If this instruction is ignored, fuel can catch fire and lead to explosion or fatal injury with burn.



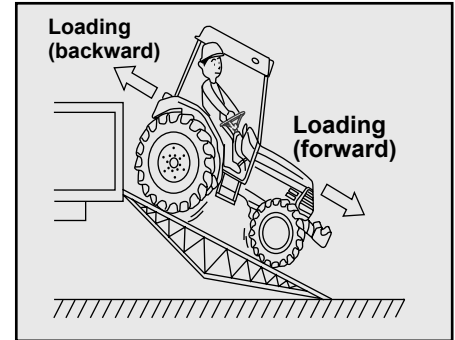
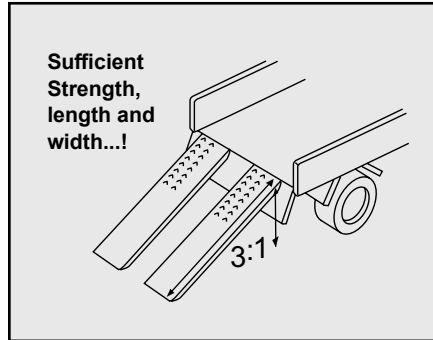
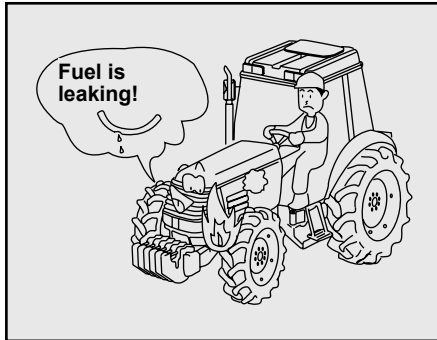

**! WARNING**

Inspect for fuel leaking;

- Check the fuel lines and hoses for damage or leakage

If this instruction is ignored, there is a risk of fire.

**! WARNING**

Consider the strength, length and width of loading ramps before using;

- Loading or unloading must be done on a flat and safe place, the tractor engine switched off, and the parking brake engaged. The loading ramps must be non-slip and have sufficient strength, length, and width for the tractor.

If this instruction is ignored, the tractor may roll backwards or fall off causing accident or injury.

**! WARNING**

Move the tractor backward when loading, and forward when unloading;

- Move the tractor backward when loading it on the truck, and forward when unloading from the truck.

If this instruction is ignored, the tractor may roll or fall off causing accident or injury.

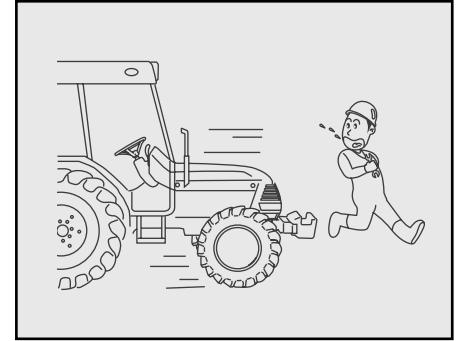
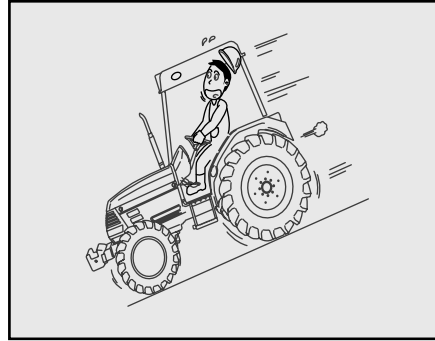
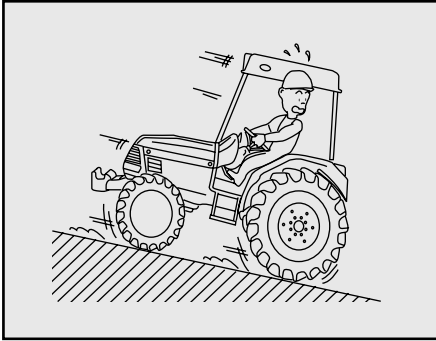
**BEFORE WORKING**

**⚠ WARNING**

Be careful when driving on the loading ramps;

- Be careful when driving on the loading ramps. Do not disengage the clutch, shift the main shift, range shift, or forward/reverse lever.

If this instruction is ignored, the tractor may roll backwards or fall causing accident or injury.

**⚠ WARNING**

Do not shift gears on slopes or on the loading ramps;

- When driving on slopes or on loading ramps, select the proper shift gear before approaching the loading ramps and then do not shift the gear on the loading ramps.

If this instruction is ignored, there is a risk of slipping, rolling, or overturning.

**⚠ CAUTION**

Stop the engine before maintenance;

- Stop the engine before maintenance when checking, repairing or cleaning the machine.

If this instruction is ignored, there is a risk of injury.

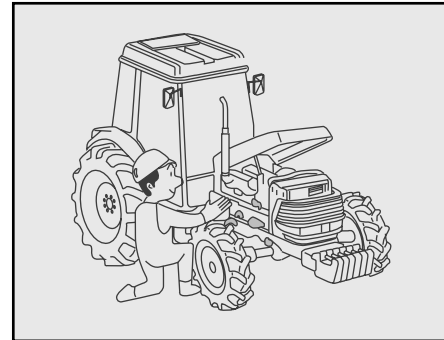
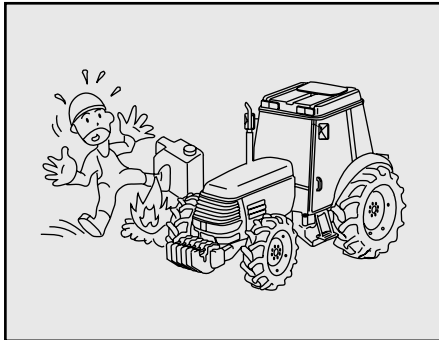

**⚠ DANGER**

Stop and cool down the engine before fueling or lubricating;

- Do not fill the fuel while the engine is running or machine is hot.

If this instruction is ignored, fuel can catch fire or lead to fatal injury with burn.

**⚠ DANGER**

No fire or spark near to the battery;

- No fire or spark near to the battery while checking and charging the battery.

If this instruction is ignored, the battery can cause a blaze or explosion and lead to a fatal injury or death.

**⚠ DANGER**

Remove dirt and debris from muffler and engine before operating;

- Clean if there is dust, debris or fuel on the engine or muffler before operating the machine every day.

If this instruction is ignored, there is a risk of fire.

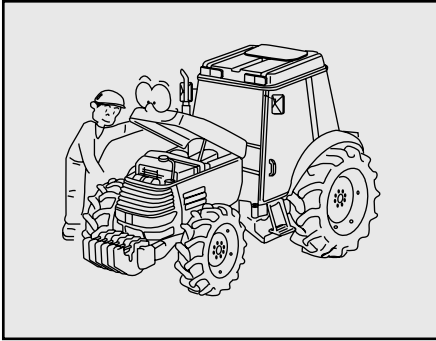

**⚠ WARNING**

Check electrical component and wire harness;

- Check before work if the wire harnesses are burned or stuck on any other component, if the cord cover is peeled off or if the wire connectors are loose.

If this instruction is ignored, the electrical short can cause fire and injury.

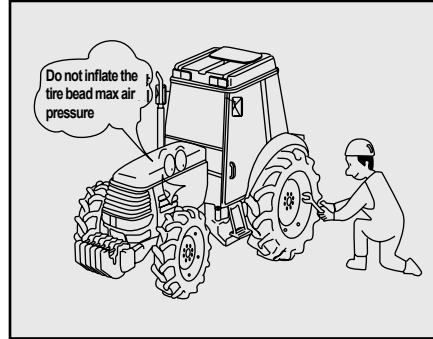

**⚠ CAUTION**

Do not over inflate tires;

- When filling tires with air, do not inflate it beyond the maximum pressure stated in this manual. (Refer to P5-42 of Proper inflation pressure)

If this instruction is ignored, the tire may blow out, causing an injury.

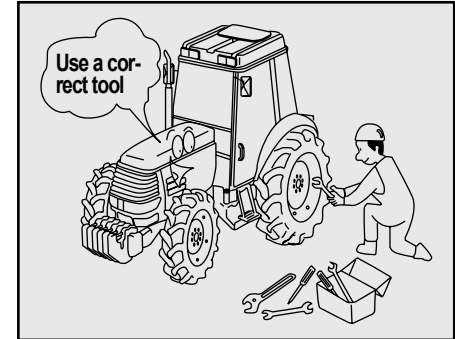

**⚠ CAUTION**

Use correct tools;

- Use proper tools to carry out all maintenance procedure. Also have available the required tools in the tractor at all times.

If this instruction is ignored, there is a risk of accident due to poor maintenance.



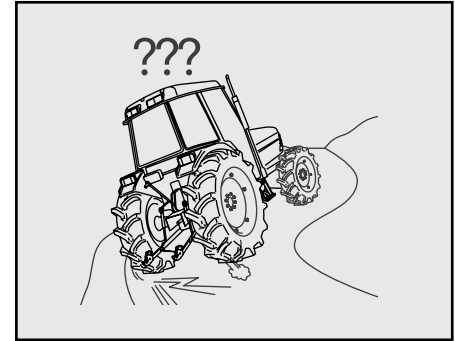
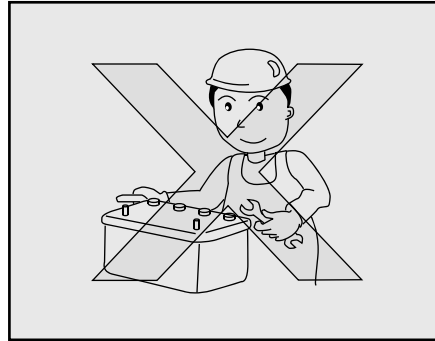
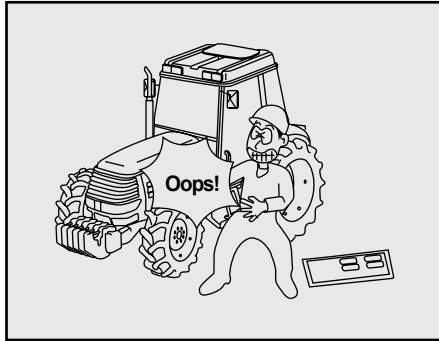

 **CAUTION**

Secure hood and side covers before operating tractor;

- After detaching the covers for checking or maintenance, make sure to put them back in their place.

If this instruction is ignored, there is a risk that you may get entangled in the tractor or get injured.

 **CAUTION**

Observe correct procedures when installing or removing the battery;

- Connect the (+) terminal first when installing the battery, and disconnect the (-) terminal first when removing it.

If this instruction is ignored, there is a risk of burn or fire due to short circuit.

 **WARNING**

It is necessary to inspect the brake to and steering wheel;

- Check if the brakes work properly and evenly on both sides or if the steering wheel is loose.

If this instruction is ignored, there is a risk of accident.

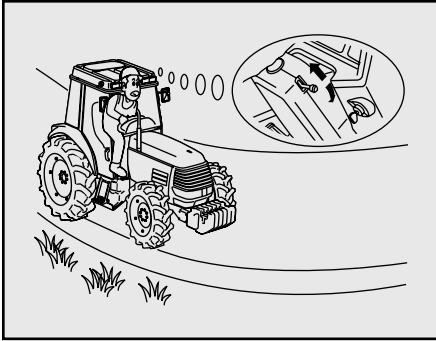

**⚠ WARNING**

Lock tilt lever and telescopic knob when adjusting steering wheel;

- Except when you adjust the steering wheel, make sure that the tilt lever and telescopic knob are secured in the “No” and “Lock” positions.

If this instruction is ignored, the tractor may not turn properly, causing an accident.

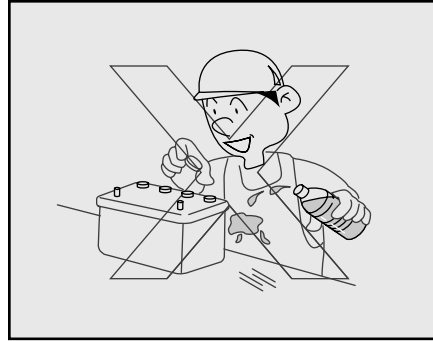

**⚠ DANGER**

Avoid contact with the battery solution;

- Be careful that your body or your clothes do not come in contact with the battery solution. If it contacts your skin, wash immediately with water.

If this instruction is ignored, it can burn your skin or clothes.

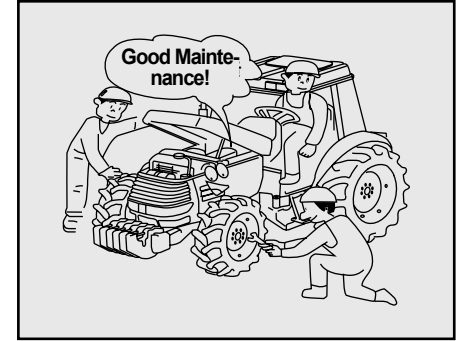

**⚠ WARNING**

Be sure to check before and after using machine;

- Be sure to check the machine before and after using. Especially inspect and repair controls such as clutch, brake, lever, etc.

If this instruction is ignored, the machine can be broken or lead to an accident or injury.

## WHILE WORKING

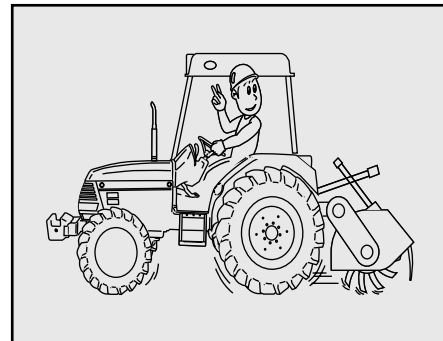
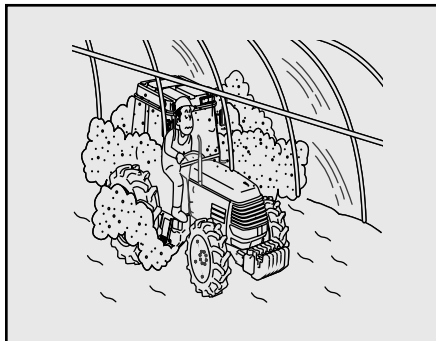
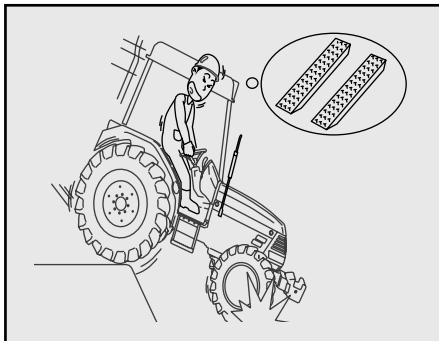

### **WARNING**

Use the loading ramps when crossing a ditch or a dike;

- Be sure to use the loading ramps when crossing a ditch or dike, or when passing through soft land. The loading ramps must be suitable for the tractor in width, length and strength.

If this instruction is ignored, there is a risk of accident that the tractor may slip or turn over.

### **WARNING**

Properly ventilate when working in a green house;

- Ventilate the green house to let out the exhaust gas.

If this instruction is ignored, the exhaust gas can cause intoxication and lead to fatal consequences.

### **WARNING**

Pay attention and keep hands on the steering wheel while driving;

If this instruction is ignored, there is a risk of accident or injury.

## AFTER USING THE MACHINE

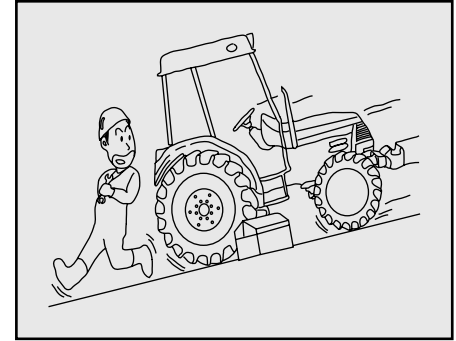
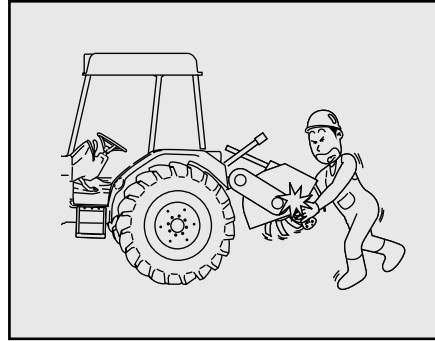
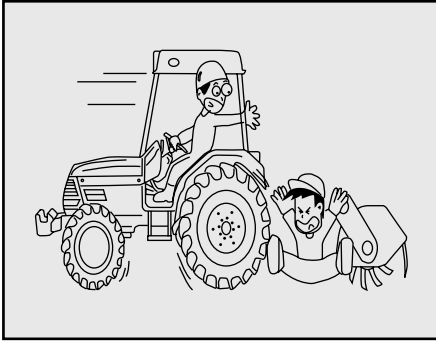

**! WARNING**

Do not allow anyone near while operating the tractor or implement;

- When engaging or disengaging the implement by moving the tractor, make sure that no one is around the tractor or between the implement and the tractor.

If this instruction is ignored, there is a risk of accident or injury.

**! WARNING**

Stop the engine when removing grass, etc. from blades of the cultivator;

- Stop the engine when removing grass, etc. from blades of the cultivator and lock the flow control valve not to lower the implement.

If this instruction is ignored, there is a risk that you will get entangled in the cultivator or sustain a serious injury due to lowering the implement.

**! WARNING**

Perform the maintenance on a level and safe location;

- Perform the maintenance on a level and safe location that will keep the tractor in place and will not cause a risk to people passing by. Before carrying out the maintenance, place blocks at the front and rear tires to prevent movement.

If this instruction is ignored, an unexpected accident may occur, such as overturning of the tractor.

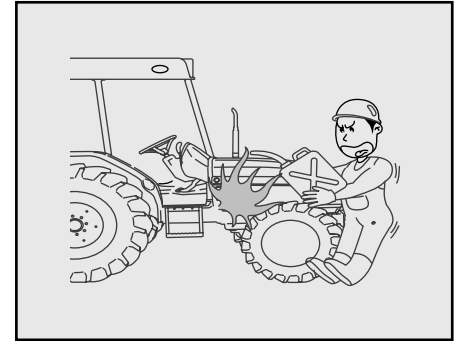
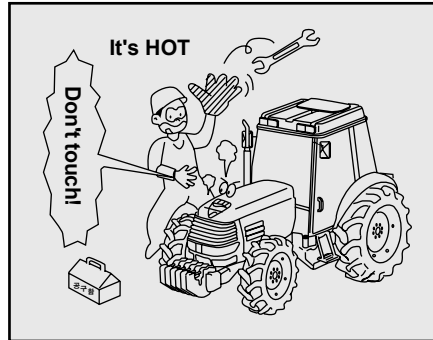
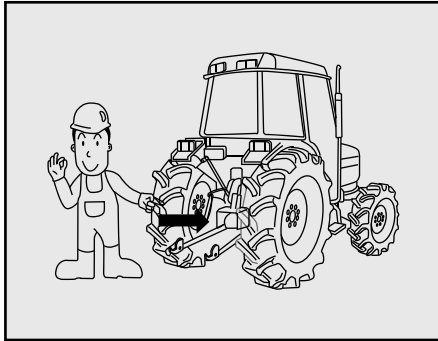

 **CAUTION**

Cover the PTO shaft when not in use;

- When the PTO shaft is not in use, apply grease and keep it covered.

If this instruction is ignored, there is a risk that you may get entangled or get injured. Implement shaft installation on the PTO shaft will not be easy due to the rust on it.

 **CAUTION**

Carry out maintenance after the parts have cooled down;

- Carry out the maintenance work after the heated area such as the muffler or the engine is fully cooled down.

If this instruction is ignored, there is a risk of getting burnt.

 **CAUTION**

Stop and cool down the engine before fueling or lubricating;

- Do not fill the fuel while the engine is running or machine is hot.

If this instruction is ignored, fuel can catch fire or lead to fatal injury with severe burns.



**⚠ CAUTION**

Be careful of high oil pressure;

- Make sure that the hydraulic coupling or the hose is not loose or damaged. Before separating the hydraulic coupling or the hose, eliminate the high pressure inside the hydraulic system by moving the control lever while engine is stopped.

If this instruction is ignored, the oil under high pressure may cause skin injury.

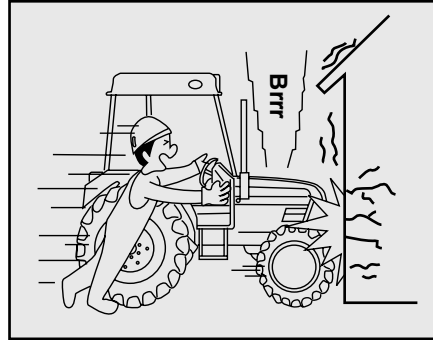

**⚠ WARNING**

Make sure that you are seated in the driver's seat with your seat belt fastened before starting engine;

- When starting the engine, make sure that you are seated in the driver's seat with your seat belt fastened and check the seat position and the safety of the tractor.

If this instruction is ignored, an unexpected accident may occur.

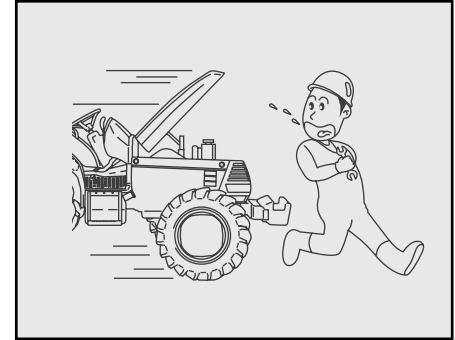

**⚠ CAUTION**

Stop the engine before maintenance;

- Stop the engine before maintenance such as checking, repairing or cleaning the machine.

If this instruction is ignored, there is a risk of injury.

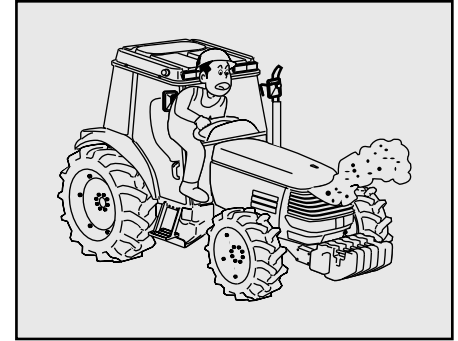
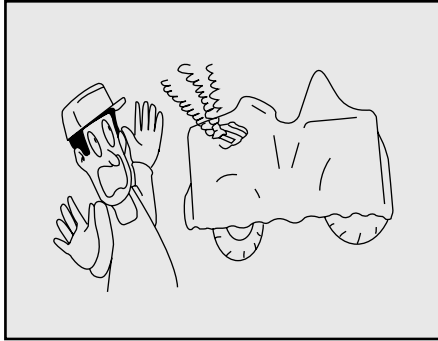

**⚠ WARNING**

Put tractor rain cover on only after tractor has cooled down;

- Put tractor rain cover on only after parts such as the engine and muffler have cooled down.

If this instruction is ignored, there is a risk of fire.

**⚠ WARNING**

Do not open the radiator cap when the radiator is hot;

- Never open the radiator cap when the radiator is heated.

If this instruction is ignored, hot water may spurt, causing burns or damage.

**⚠ WARNING**

Remove dirt and debris from muffler and engine before operating;

- Clean if there is dust, debris or fuel on the engine or muffler before operating the machine every day.

If this instruction is ignored, there is a risk of fire.

## PRECAUTION FOR PROLONGED STORAGE

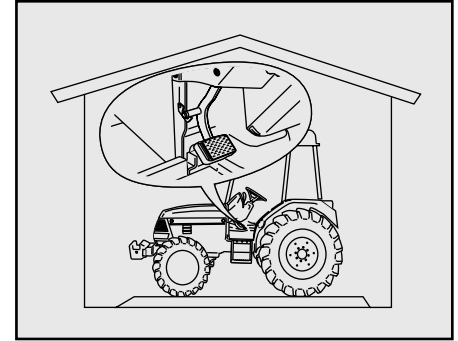
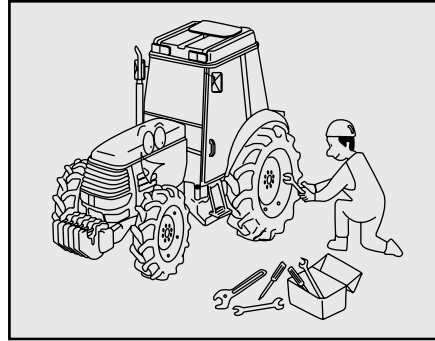
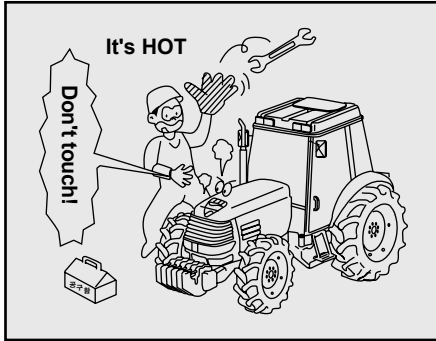

### ⚠ CAUTION

Be careful of hot muffler;

- During operation and right after the engine is turned off, the muffler is very hot. Avoid touching it.

If this instruction is ignored, you may get burnt.

### ⚠ CAUTION

After working, immediately repair if necessary;

- Immediately repair or replace the faulty parts.
  - Tighten the loose bolt and nut right away.

If this instruction is ignored, an unexpected accident may occur due to poor maintenance.

### ⚠ CAUTION

Disengage the clutch when storing the tractor for a long time;

- When storing the tractor for a long period of time, make sure to put the clutch pedal in the disengaging position.

If this instruction is ignored, the clutch disc can be stuck to the fly wheel after long period time.



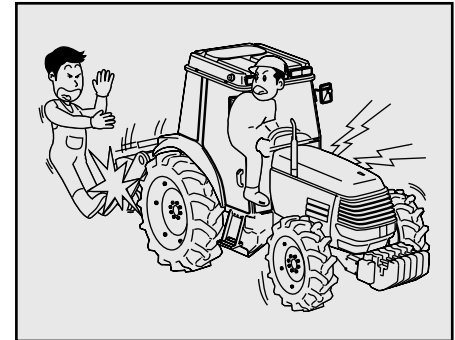
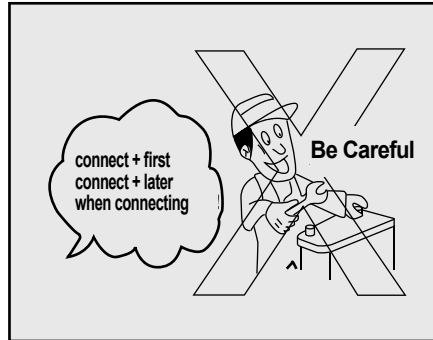
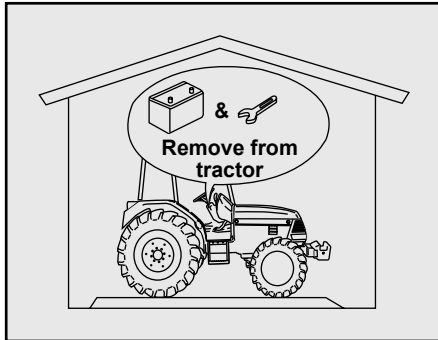

**! WARNING**

Disconnect the Battery and the key when storing the tractor for a long period of time;

- When storing the tractor without use for a long period of time, park the machine on the leveled ground and clean each component, remove the battery and keep the key in a safe place.

If this instruction is ignored, battery power may be weakened and starting will be failed.

**! CAUTION**

Observe correct procedures when installing or removing the battery;

- Connect the (+) terminal first when installing the battery, and disconnect the (-) terminal first when removing it.

If this instruction is ignored, there is a risk of burn or fire due to short circuit.

**! WARNING**

Confirm that the implement is down on the ground when starting the engine;

- When starting the engine, confirm that the control lever is on "Lowest" position.

If this instruction is ignored, implement may come down suddenly and cause an injury.

## OTHER

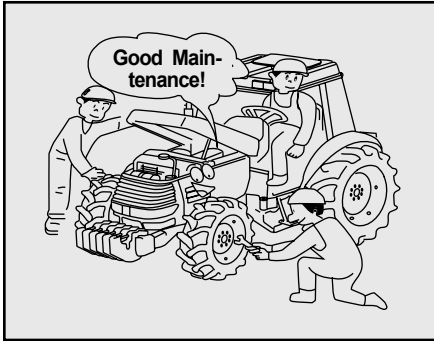

**! WARNING**

Maintenance periodically;

- After using tractor, visit your local dealer for maintenance, such as oil change and filters.
  - Contact the local dealer to discard the parts (battery, etc.) or waste materials.

If this instruction is ignored, there is a risk of accident due to poor maintenance.

**! WARNING**

Do not adjust or repair following components. Consult your local BAD BOY dealer for these repair;

- Injection capacity and timing of the engine fuel injection pump.
- Correction and repair of hydraulic system (safety valve, hydraulic pump, brake valve, PST cylinder, SCV valve).

There is a risk of accident or injury or machinery breakdown. Remember it may cause the warranty cancellation.

If this instruction is ignored, consult your local BAD BOY dealer for those repair and adjustment.

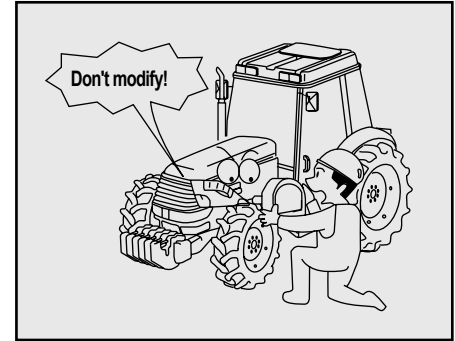

**! CAUTION**

Do not modify the tractor;

- Use only the genuine parts or other approved parts. Do not modify the tractor.

If this instruction is ignored, there is a risk of accident or injury or machinery breakdown. Remember it may cause the warranty cancellation.

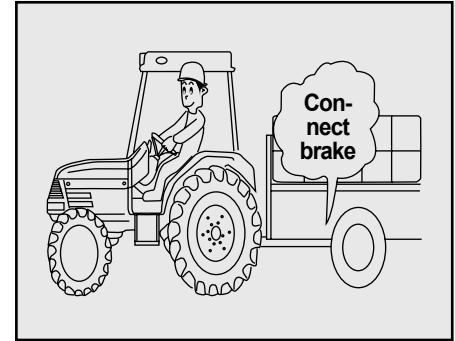
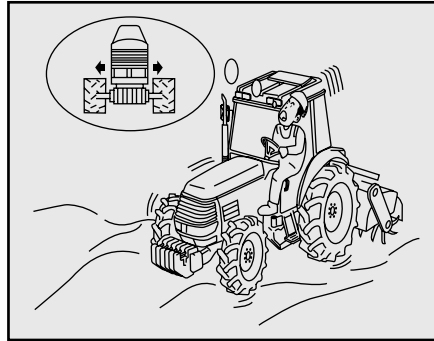

**⚠ WARNING**

Pay attention when turning with implement;

- Depending on implements, the overall length may become very long. Pay particular attention to people or objects nearby when making a turn.

If this instruction is ignored, there is a risk of person injury or a collision of the implement.

**⚠ WARNING**

Move wheels to widest setting (width between left and right tires) when working slope or when towing;

If this instruction is ignored, there is a risk of turning over.

**⚠ WARNING**

Use caution sign when towing a trailer;

- Link the brake of the trailer with the brake of the tractor. Do not shift gears when driving on a hill.

If this instruction is ignored, there is a risk of accident or injury.

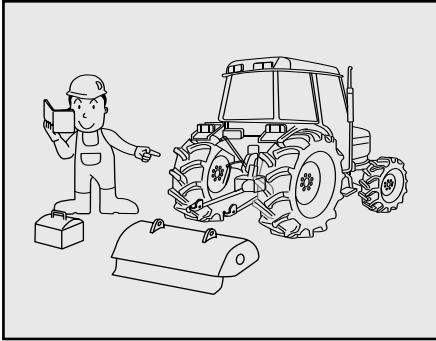

**⚠ WARNING**

Follow the instruction manual when engaging an implement;

- When engaging an implement to the tractor, follow the instruction manual for the implement.

If this instruction is ignored, there is a risk of personal injury or damage to the tractor.

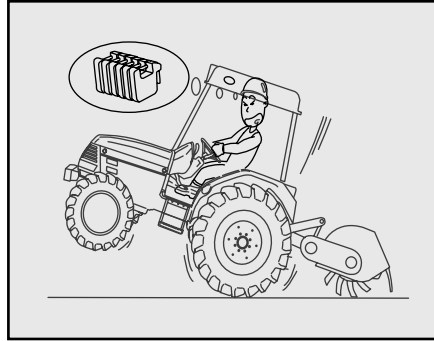

**⚠ WARNING**

Balance a heavy implement with weights;

- When engaging a heavy implement, load the weights on the front of tractor to keep the balance of the tractor.

If this instruction is ignored, there is a risk of accident or injury due to loss of balance.

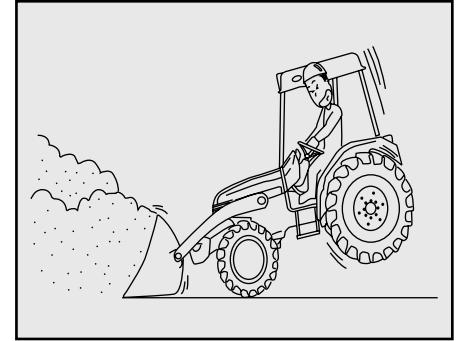

**⚠ WARNING**

Pay attention to the balance between the front and rear side during the front-end-loader operation;

- During the front-end-loader operation, apply weights or implement to avoid losing balance between the front and the rear side of tractor.

If this instruction is ignored, there is a risk of overturning accident due to loss of balance.

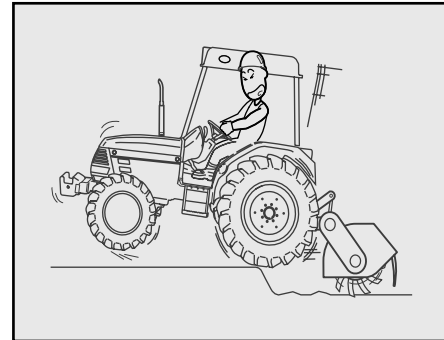
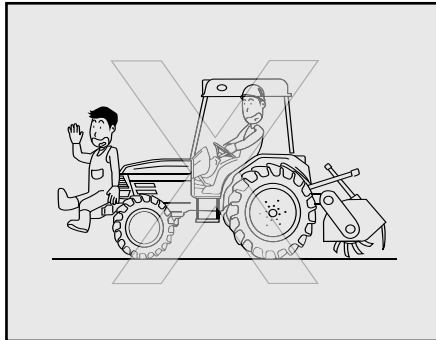
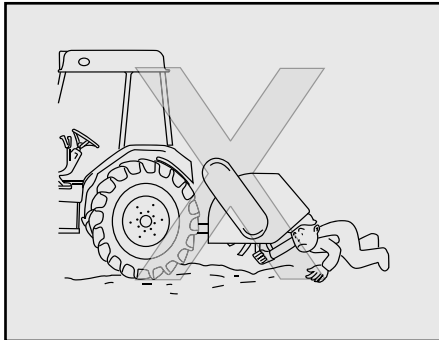

**⚠ WARNING**

Do not get under or put your feet under the implement;

- Do not get under or put your feet under the implement.

If this instruction is ignored, the implement unit may fall down and there is a risk of injury.

**⚠ WARNING**

Do not substitute balance weights with a person or anything else;

- Do not use a person or anything else in place of the balance weight. Use only genuine balance weight.

If this instruction is ignored, there is a risk of accident or injury.

**⚠ WARNING**

Be careful of unexpected movement when using the rotary tiller;

- When working with the rotary tiller, put the tiller slowly on soft or rocky ground. The tractor may be pushed in an unexpected direction by the rotating force of the tiller.

If this instruction is ignored, there is a risk of accident or injury.

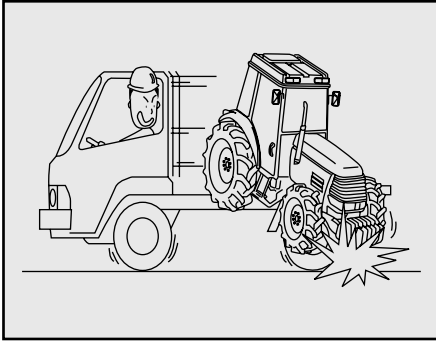

**! WARNING**

Properly secure tractor during transport;

- When transporting the tractor, apply the parking brake with gear engaged and fasten the tractor to the truck securely using ropes or belts with sufficient strength.

If this instruction is ignored, There is a risk of accident that the tractor may fall off the truck.

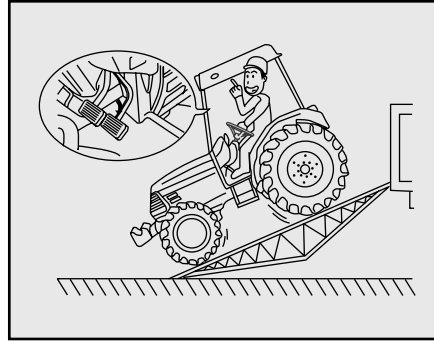

**! DANGER**

Interlock the brake pedals for both sides when loading or unloading the tractor;

- It is necessary to interlock the brake pedals for both sides when loading or unloading the tractor.

If this instruction is ignored, the tractor may overturn due to one-sided braking when the brake pedal is depressed in an emergency.

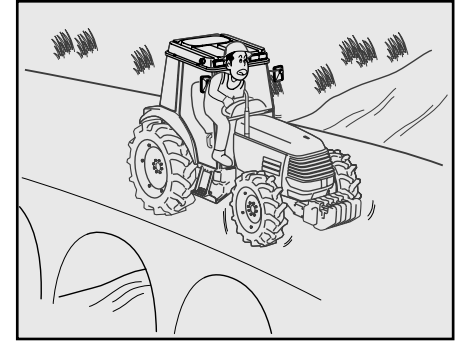

**! WARNING**

Release the differential gear lock when making a turn;

- Make sure to release the differential gear lock when making a turn.

If this instruction is ignored, the tractor may not turn to the intended direction and cause an accident.

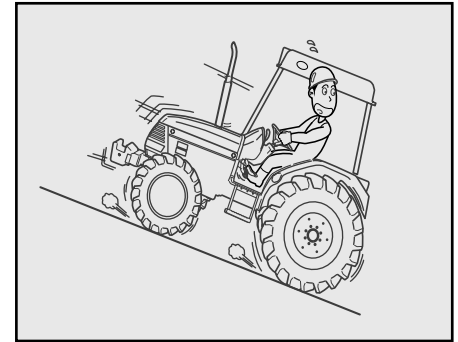
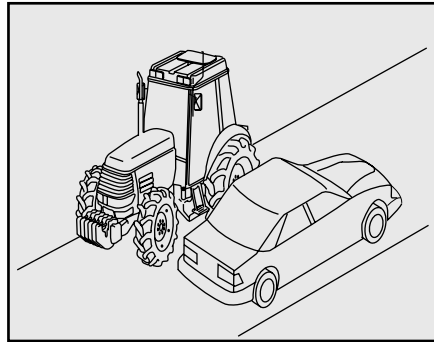
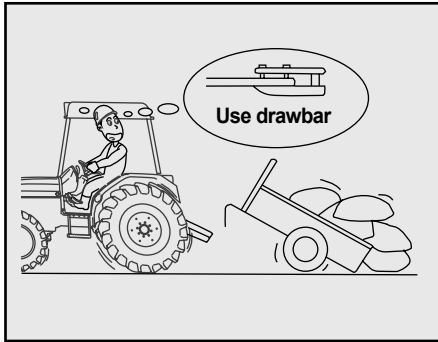

**! WARNING**

Use the drawbar when towing;

- Make sure to use the drawbar when towing. Never tow anything with the top link or the lower links.

If this instruction is ignored, the tractor may turn over.

**! WARNING**

Pay attention to the shoulder of the road;

- When moving along the unpaved road with ditches or slanted sides, pay attention to the road shoulder.

If this instruction is ignored, there is a risk of falling over.

**! WARNING**

Be careful when driving on a hill;

- Be careful when driving on a hill. Do not disengage the clutch on the hill. Do not shift the main shift lever, range shift lever, or shuttle lever in [neutral] on the hill.

If this instruction is ignored, the tractor may roll backwards or fall causing accident or injury.

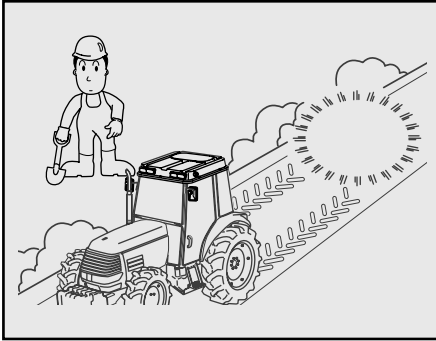

**! WARNING**

Turn off engine in a level area when leaving the tractor;

- When leaving the tractor, park the tractor on a level and safe area, turn off the engine, and apply the parking brake. Also, lower the implement on the ground.

If this instruction is ignored, the tractor may move and cause an accident.

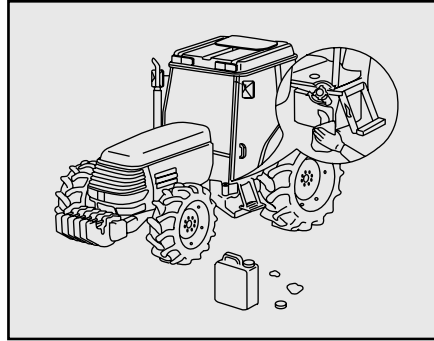

**! WARNING**

Remove spilled excess fuel after closing the fuel cap;

- After filling the fuel tank, close the fuel filler cap completely and wipe off the excess fuel thoroughly.

If this instruction is ignored, there is a risk of fire.

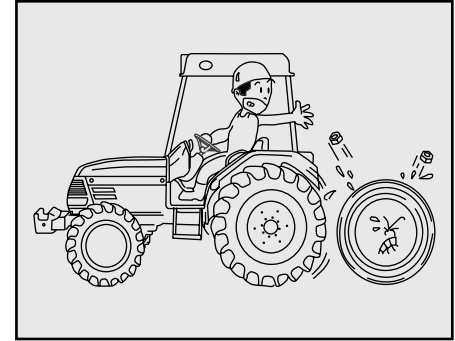

**! WARNING**

Be aware of the PTO RPM requirements for the implements;

If this instruction is ignored, there is a risk of accident or injury.



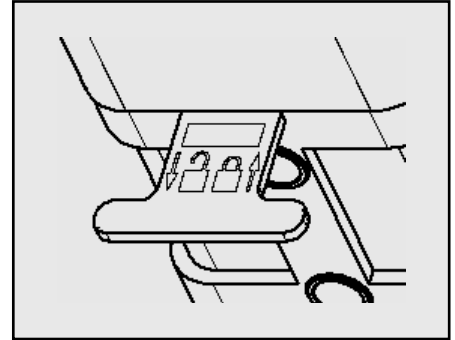
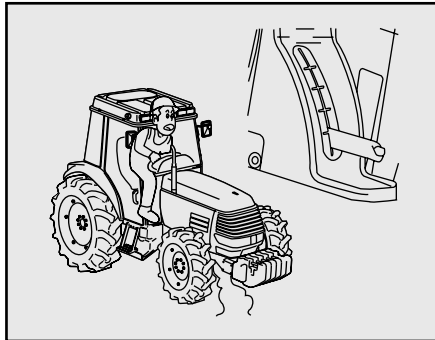
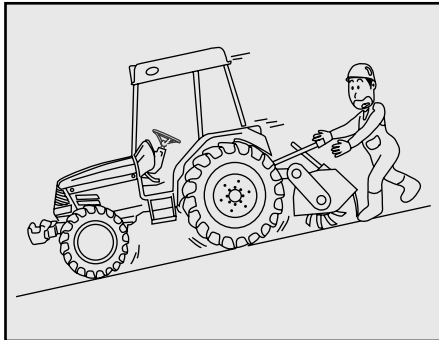

**⚠ WARNING**

Only engage or disengage implements on flat, level area:

- Engage or disengage the implement on a flat and safe place. Supply proper lighting at all times and especially night.

[Otherwise]

There is a danger of accident.

**⚠ CAUTION**

Engage the parking brake during warming up the engine;

If this instruction is ignored, the tractor may move and cause an accident or injury.

**⚠ WARNING**

- Check and perform maintenance to loader after lifting it. And fix the joystick safety lever when dismantling .

[Otherwise]

There is a danger of an unexpected death accident.

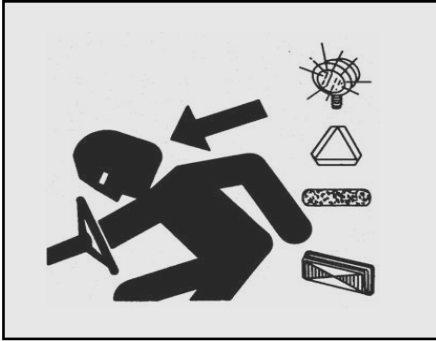

1. When the tractor has an implement attached or is moving slowly, you must often watch the rear side traffic status to avoid a collision accident when traveling on the road. In particular, be careful when you change directions. If necessary, the signal must be given by hand or direction indication lamp must be used.
2. Always turn on the head light, and/or emergency lamp at night and day as requested by the local traffic regulation.

3. Maintain the light and indication plate so it can be visible always. Immediately repair or attach the broken or missed light and indicating plates.

**CAUTION**

- Item regarding lighting devices. (alarm lamp and safety device)



1. Entanglement in rotating drive-line can cause serious injury or death.
2. Keep tractor master shield and drive-line shields in place at all times. Make sure rotating shields turn freely.
3. Understand service procedure before doing work. Keep area clean and dry.



4. Never lubricate, service, or adjust machine while it is moving. Keep hands, feet, and clothing from power-driven parts. Disengage all power and operate controls to relieve pressure. Lower equipment to the ground. Stop the engine. Remove the key. Allow machine to be cooled.
5. Securely support any machine elements that must be raised for service work.

6. Keep all parts in good condition and properly installed. Fix damage immediately. Replace worn or broken parts. Remove any buildup of grease, oil, or debris.
7. On self-propelled equipment, disconnect battery ground cable (-) before making adjustments on electrical systems or welding on machine.
8. On towed implements, disconnect wiring harnesses from tractor before servicing electrical system components or welding on machine.

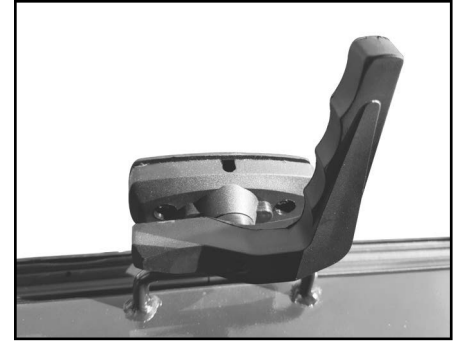

► **LOCATION AND METHOD OF OPENING OF EMERGENCY EXITS**

Removable rear cab window provides a large exit path if the cab door is blocked in an emergency situation.

The following items, maintenance and adjustment should not be attempted, but contact the nearest authorized dealer, if necessary.

1. Adjustment of injection pump without pre-approval may cause to deteriorate the durability and performance of the engine and may cause a fatal malfunction.
2. Adjustment of hydraulic pressure set at shipment may cause a fatal failure of related components and a subsequent accident.
3. If you intend to adjust the components that may deteriorate durability and performance, always contact your nearest authorized dealer or service department of the head office.

**[Otherwise]**

Be careful it may cause a fatal error or may not be covered by the warranty.

Use agricultural chemicals in a safe manner.

1. Agricultural chemicals must be sprayed properly.
2. Spraying of agricultural chemicals must be noticed in advanced and damage to the surroundings.
3. Do wear the protective clothing (mask, glove) for agricultural chemicals before spray work.
4. Clean the equipment and tractor just after spraying work.

**[Otherwise]**

You may be exposed to agricultural chemicals by wind.





# DECAL ROPS

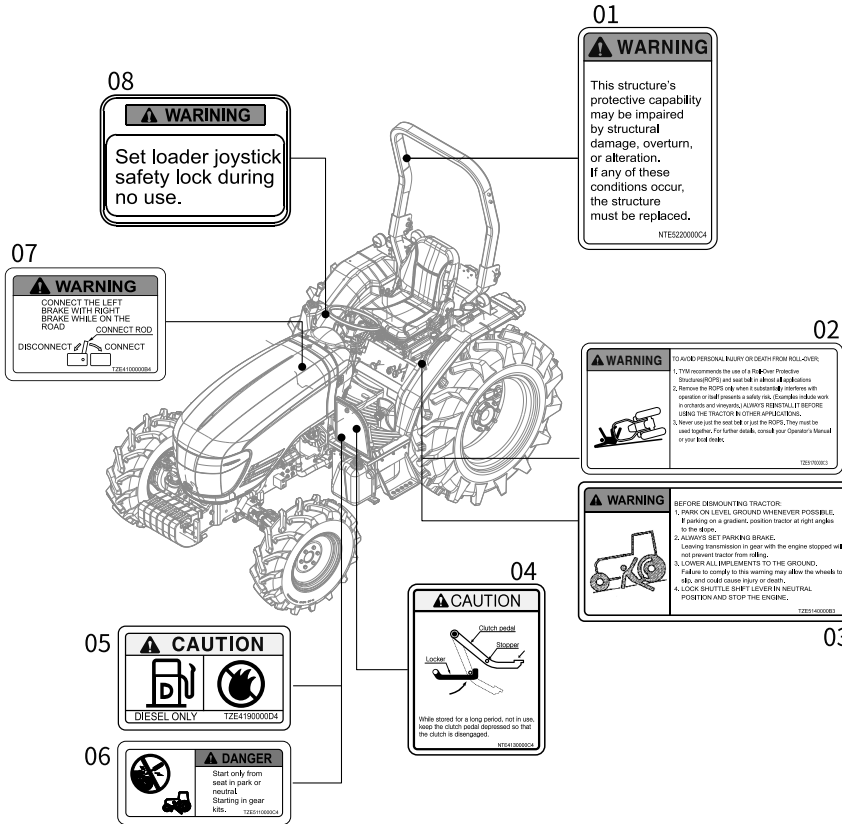

No	Part Code	Part Description
1	NTE5220000	WARNING
2	TZE5170000	WARNING-ROPS
3	TZE5140000	CAUTION-GETTING OFF
4	NTE4130000	SINGLE CLUTCH
5	TZE4190000	REFUEL
6	TZE5110000	START
7	TZE4100000	BRAKE PEDAL
8	TA00026342	JOYSTICK

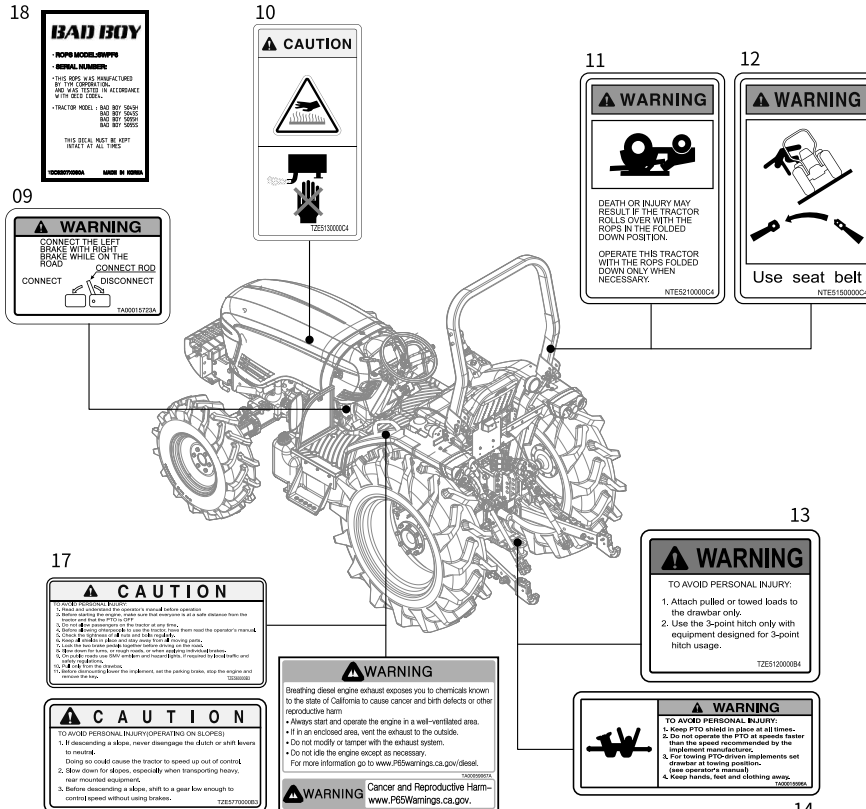

No	Part Code	Part Description
9	TA00015723	BRAKE PEDAL(HST)
10	TZE5130000	CAUTION
11	NTE5210000	WARNING
12	NTE5150000	SEAT BELT
13	TZE5120000	WARNING-CONNECTION
14	TA00015596	WARNING-PTO
15	TA00059067	WARNING-CALIFORNIA
16	TZE5770000	CAUTION-SAFETY
17	TZE5160000	CAUTION-SAFETY
18	TDC9207X090	LABEL, ROPS



## CAUTIONS FOR DECAL MAINTENANCE

Safety decals are attached to the tractor for safe operation. Make sure to follow the instruction on the decals as well as the following instruction:



### CAUTION

- **Keep the decals clean and intact. If any decal is dirty, wash it with soap and dry with a soft cloth.**
- **Never use a solvent such a thinner or acetone, since it can ruin the decals.**
- **Do not spray high-pressure water directly onto the decal. The decal may fall off the tractor.**



### IMPORTANT

- **If a decal is damaged or lost, contact your local BAD BOY dealer immediately to install a new decal.**
- **Make sure to attach the decal in the correct position cleanly without bubbles after cleaning its mounting surface.**
- **If a decal is attached to a component to be replaced, replace the decal as well.**

## 2. REGARDING WARRANTY SUPPORT

<b>REGARDING WARRANTY CERTIFICATE.....</b>	<b>2-2</b>
<b>REGARDING AFTER-SALES SERVICE .....</b>	<b>2-2</b>
VEHICLE IDENTIFICATION NUMBER (VIN) .....	2-2
<b>REGARDING SUPPLYING SERVICE PARTS.....</b>	<b>2-3</b>
<b>REGARDING GENUINE PARTS AND FLUID .....</b>	<b>2-3</b>

## REGARDING WARRANTY CERTIFICATE

### **WARNING**

- Do not modify the machine. If it is damaged by unapproved modification and misuse against description of manual, it will not be covered under warranty.

## REGARDING AFTER-SALES SERVICE VEHICLE IDENTIFICATION NUMBER (VIN)

### ► PRODUCTION SERIAL NUMBER

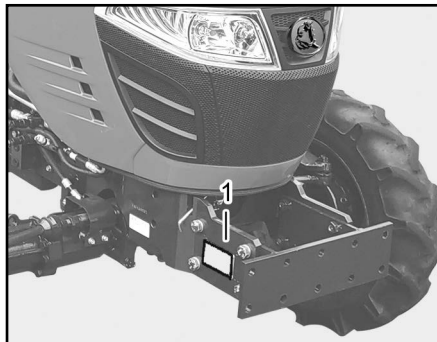

(1) Model And Production Serial Number

The manufacturer's serial number is marked on the serial number decal which is attached to the front left side of the front axle bracket.

### ► ENGINE SERIAL NUMBER

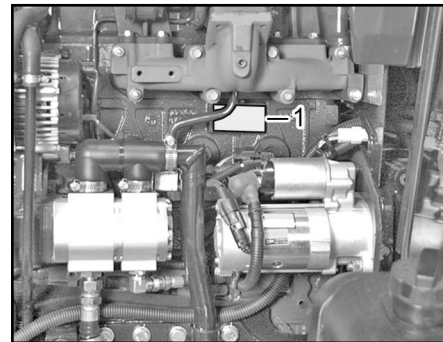

(1) Engine Serial Number

The engine number is stamped on the cylinder block and is specified on the decal which is attached to the cylinder block on the top of the engine. Also, the decal indicating the engine model and standards is attached on the top of the engine cylinder head cover.

## REGARDING SUPPLYING SERVICE PARTS

### ► REGARDING AFTER-SALES SERVICE

If you have a problem on your machine, refer to “Troubleshooting” of chapter 7 to check by yourself. Or contact immediately to an authorized **BAD BOY** dealer nearby.

### ► BE PREPARE FOR THE FOLLOWING QUESTION BEFORE CALLING

- Model and product serial number
- In case of engine failure, engine serial number
- Working conditions  
(What kind of job and how fast)
- Run hour of machine
- Describe the problem in detail as possible

We supply the service parts in accordance with the separated quality assurance regulation.

Consult your local dealer for availability and pricing.

## REGARDING GENUINE PARTS AND FLUID

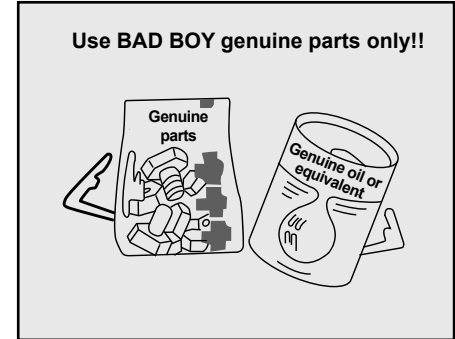

The **BAD BOY** genuine parts and fluid are passed severe durability and performance test. Please use **BAD BOY** genuine parts for your safety.

# MEMO

A series of horizontal dotted lines for writing.

# 3. SPECIFICATIONS

MAJOR SPECIFICATIONS .....3-2  
DRIVING SPEED .....3-14

## SPECIFICATIONS

### [CABIN - SYNCHRO]

Specification		Models	5045CS	5055CS
Engine	Model		A2300N3	A2300T11
	Aspiration		Natural	Turbo
	Emissions Standards		Tier 4	Tier 4
	Gross Power HP	HP (kW)	48.0 (36.0)	55.0 (41.0)
	PTO HP	HP (kW)	38.4 (28.6)	44.0 (32.8)
	No. of Cylinders		4	4
	Displacement	cu.in (cc)	139.5 (2,286)	139.5 (2,286)
	Rated Revolution	RPM	2,600	2,600
	Max Torque	lb-ft (Nm)	110.0 (150.0)	131.3 (178.0)
	Fuel Tank Capacity	gal (ℓ)	11.8 (45.0)	11.8 (45.0)
	Fuel Consumption	gal.hr (ℓ / hr)	3.0 (11.5)	3.9 (14.9)
	Air Cleaner		Dry Element	Dry Element
Alternator	12 volt amp	70	70	

Specification		Models	5045CS	5055CS
<b>Drivetrain</b>	Transmission		Synchromesh	Synchromesh
	Forward/Reverse Method		Synchromesh	Synchromesh
	4 Wheel Drive		2WD/4WD	2WD/4WD
	No. of Traveling Speeds		16F / 16R (4 Range)	16F / 16R (4 Range)
	Forward Traveling Speed	mph (km/h)	16.0 (25.7)	16.0 (25.7)
	Reverse Traveling Speed	mph (km/h)	15.2 (24.5)	15.2 (24.5)
	Clutch		Dry Single Type (N/A)	Dry Single Type (N/A)
	Brake		Wet, Multi-disc	Wet, Multi-disc
	Differential Lock		Standard	Standard
	Creeper		No	No
	Cruise Control		No	No
<b>Hydraulics</b>	Power Steering		Hydrostatic Power Steering	Hydrostatic Power Steering
	Total Hydraulic Flow (POWER STEERING+Implement)	gpm/ lpm	14.3 (4.4+9.9) / 54.2 (16.8+37.4)	14.3 (4.4+9.9) / 54.2 (16.8+37.4)
	Lift Control Type		Position	Position
	Joystick Valve		Standard	Standard
	Rear Remote(Port)		4Port	4Port



Specification		Models	5045CS	5055CS
<b>3 Point Hitch</b>	3 Point Hitch		CAT I	CAT I
	Lift capacity at lift link ends	lbs (kg)	3,306 (1,500)	3,306 (1,500)
	3Point Hitch Lift Capacity @24" behind lift point	lbs (kg)	2,425 (1,100)	2,425 (1,100)
<b>PTO</b>	Rear(Mid) PTO Speed	RPM	540 / 540E	540 / 540E
	Rear PTO Type		Independent	Independent
	Clutch		Wet, Multi-disc	Wet, Multi-disc
<b>Tires</b>	Front		9.5 - 16	9.5 - 16
	Rear		13.6 - 26	13.6 - 26
<b>Dimensions</b>	Wheelbase	in. (mm)	71.1 (1,806)	71.1 (1,806)
	Overall Length(W/ 3PT)	in. (mm)	127.4 (3,236)	127.4 (3,236)
	Min.Overall Width	in. (mm)	64.9 (1,650)	64.9 (1,650)
	Overall Height(W/ ROPS)	in. (mm)	97.0 (2,463)	97.0 (2,463)
	Ground Clearance(4WD)	in. (mm)	15.5 (394.0)	15.5 (394.0)
	Min.Turning Radius(W/ Brake)	feet (m)	9.18 (2.80)	9.18 (2.80)
	Turning Degree		45	45
	Weight(W/O Front Weights)	lbs (kg)	4,349 (1,973)	4,349 (1,973)

※ Specifications are subject to change without notice. Contact your local dealer for more information.

**[CABIN - HST]**

Specification		Models	5045CH	5055CH
<b>Engine</b>	Model		A2300N3	A2300T11
	Aspiration		Natural	Turbo
	Emissions Standards		Tier 4	Tier 4
	Gross Power HP	HP (kW)	48.0 (36.0)	55.0 (41.0)
	PTO HP	HP (kW)	38.4 (28.6)	44.0 (32.8)
	No. of Cylinders		4	4
	Displacement	cu.in (cc)	139.5 (2,286)	139.5 (2,286)
	Rated Revolution	RPM	2,600	2,600
	Max Torque	lb-ft (Nm)	110.0 (150.0)	131.3 (178.0)
	Fuel Tank Capacity	gal (ℓ)	11.8 (45.0)	11.8 (45.0)
	Fuel Consumption	gal.hr (ℓ/hr)	3.0 (11.5)	3.9 (14.9)
	Air Cleaner		Dry Element	Dry Element
Alternator	12volt amp	70	70	

**3-6 BAD BOY TRACTOR**

Specification		Models	5045CH	5055CH
<b>Drivetrain</b>	Transmission		HST	HST
	Forward/Reverse Method		HST	HST
	4 Wheel Drive		2WD/4WD	2WD/4WD
	No. of Traveling Speeds		4F / 4R (4 Range)	4F / 4R (4 Range)
	Forward Traveling Speed	mph (km/h)	19.5 (31.4)	19.5 (31.4)
	Reverse Traveling Speed	mph (km/h)	19.5 (31.4)	19.5 (31.4)
	Clutch		Dry Single Type (N/A)	Dry Single Type (N/A)
	Brake		Wet, Multi-disc	Wet, Multi-disc
	Differential Lock		Standard	Standard
	Creep		No	No
Cruise Control		Standard	Standard	
<b>Hydraulics</b>	Power Steering		Hydrostatic Power Steering	Hydrostatic Power Steering
	Total Hydraulic Flow (POWER STEERING+Implement)	gpm/ lpm	13.7 (4.4+9.3) / 51.9 (16.8+35.1)	13.7 (4.4+9.3) / 51.9 (16.8+35.1)"
	Lift Control Type		Position	Position
	Joystick Valve		Standard	Standard
	Rear Remote(Port)		4Port	4Port

Specification		Models	5045CH	5055CH
3 Point Hitch	3 Point Hitch		CAT I	CAT I
	Lift capacity at lift link ends	lbs (kg)	3,306 (1,500)	3,306 (1,500)
	3Point Hitch Lift Capacity @24" behind lift point	lbs (kg)	2,425 (1,100)	2,425 (1,100)
PTO	Rear(Mid) PTO Speed	RPM	540 / 540E	540 / 540E
	Rear PTO Type		Independent	Independent
	Clutch		Wet, Multi-disc	Wet, Multi-disc
Tires	Front		9.5 - 16	9.5 - 16
	Rear		13.6 - 26	13.6 - 26
Dimensions	Wheelbase	in. (mm)	71.1 (1,806)	71.1 (1,806)
	Overall Length(W/ 3PT)	in. (mm)	127.4 (3,236)	127.4 (3,236)
	Min.Overall Width	in. (mm)	64.9 (1,650)	64.9 (1,650)
	Overall Height(W/ ROPS)	in. (mm)	97.0 (2,463)	97.0 (2,463)
	Ground Clearance(4WD)	in. (mm)	15.5 (394.0)	15.5 (394.0)
	Min.Turning Radius(W/ Brake)	feet (m)	9.18 (2.80)	9.18 (2.80)
	Turning Degree		45	45
	Weight(W/O Front Weights)	lbs (kg)	4,349 (1,973)	4,349 (1,973)

※ Specifications are subject to change without notice. Contact your local dealer for more information.

\*540E: Economic

**[ROPS - SYNCHRO]**

Specification		Models	5045S	5055S
<b>Engine</b>	Model		A2300N2	A2300T3
	Aspiration		Natural	Turbo
	Emissions Standards		Tier 4	Tier 4
	Gross Power HP	HP (kW)	48.0 (36.0)	55.0 (41.0)
	PTO HP	HP (kW)	38.4 (28.6)	44.0 (32.8)
	No. of Cylinders		4	4
	Displacement	cu.in (cc)	139.5 (2,286)	139.5 (2,286)
	Rated Revolution	RPM	2,600	2,600
	Max Torque	lb-ft (Nm)	110.0 (150.0)	131.3 (178)
	Fuel Tank Capacity	gal (ℓ)	11.8 (45.0)	11.8 (45.0)
	Fuel Consumption	gal.hr (ℓ/hr)	3.0 (11.5)	3.9 (14.9)
	Air Cleaner		Dry Element	Dry Element
Alternator	12volt amp	50	50	

Specification		Models	5045S	5055S
<b>Drivetrain</b>	Transmission		Synchromesh	Synchromesh
	Forward / Reverse Method		Synchroshuttle	Synchroshuttle
	4 Wheel Drive		2WD/4WD	2WD/4WD
	No. of Traveling Speeds		16F / 16R (4 Range)	16F / 16R (4 Range)
	Forward Traveling Speed	mph (km/h)	16.0 (25.7)	16.0 (25.7)
	Reverse Traveling Speed	mph (km/h)	15.2 (24.5)	15.2 (24.5)
	Clutch		Dry Single Type (N/A)	Dry Single Type (N/A)
	Brake		Wet, Multi-disc	Wet, Multi-disc
	Differential Lock		Standard	Standard
	Creeper		No	No
	Cruise Control		No	No
<b>Hydraulics</b>	Power Steering		Hydrostatic Power Steering	Hydrostatic Power Steering
	Total Hydraulic Flow (POWER STEERING+Implement)	gpm/ lpm	14.3 (4.4+9.9) / 54.2 (16.8+37.4)	14.3 (4.4+9.9) / 54.2 (16.8+37.4)
	Lift Control Type		Position	Position
	Joystick Valve		Standard	Standard
	Rear Remote (Port)		Optional (Up to 4)	Optional (Up to 4)

### 3-10 BAD BOY TRACTOR

Specification		Models	5045S	5055S
3 Point Hitch	3 Point Hitch		CAT I	CAT I
	Lift capacity at lift link ends	lbs (kg)	3,306 (1,500)	3,306 (1,500)
	3Point Hitch Lift Capacity @24" behind lift point	lbs (kg)	2,425 (1,100)	2,425 (1,100)
PTO	Rear(Mid) PTO Speed	RPM	540 / 540E	540 / 540E
	Rear PTO Type		Independent	Independent
	Clutch		Wet, Multi-disc	Wet, Multi-disc
Tires	Front		9.5 - 16	9.5 - 16
	Rear		13.6 - 26	13.6 - 26
Dimensions	Wheelbase	in. (mm)	71.10 (1,806)	71.1 (1,806)
	Overall Length(W/ 3PT)	in. (mm)	127.40 (3,236)	127.4 (3,236)
	Min.Overall Width	in. (mm)	64.90 (1,650)	64.9 (1,650)
	Overall Height(W/ ROPS)	in. (mm)	98.40 (2,500)	98.4 (2,500)
	Ground Clearance(4WD)	in. (mm)	15.50 (394.0)	15.5 (394.0)
	Min.Turning Radius(W/ Brake)	feet (m)	9.18 (2.80)	9.18 (2.80)
	Turning Degree		45	45
	Weight(W/O Front Weights)	lbs (kg)	3,831 (1,738)	3,836 (1,740)

※ Specifications are subject to change without notice. Contact your local dealer for more information.

\*540E: Economic

**[ROPS - HST]**

Specification		Models	5045H	5055H
<b>Engine</b>	Model		A2300N2	A2300T3
	Aspiration		Natural	Turbo
	Emissions Standards		Tier 4	Tier 4
	Gross Power HP	HP (kW)	48.0 (36.0)	55.0 (41.0)
	PTO HP	HP (kW)	38.4 (28.6)	44.0 (32.8)
	No. of Cylinders		4	4
	Displacement	cu.in (cc)	139.5 (2,286)	139.5 (2,286)
	Rated Revolution	RPM	2,600	2,600
	Max Torque	lb-ft (Nm)	110.0 (150.0)	131.3 (178.0)
	Fuel Tank Capacity	gal (ℓ)	11.8 (45.0)	11.8 (45.0)
	Fuel Consumption	gal.hr (ℓ/hr)	3.0 (11.5)	3.9 (14.9)
	Air Cleaner		Dry Element	Dry Element
Alternator	12volt amp	50	50	



Specification		Models	5045H	5055H
<b>Drivetrain</b>	Transmission		HST	HST
	Forward/Reverse Method		HST	HST
	4 Wheel Drive		2WD/4WD	2WD/4WD
	No. of Traveling Speeds		4F / 4R (4 Range)	4F / 4R (4 Range)
	Forward Traveling Speed	mph (km/h)	19.5 (31.4)	19.5 (31.4)
	Reverse Traveling Speed	mph (km/h)	19.5 (31.4)	19.5 (31.4)
	Clutch		Dry Single Type (N/A)	Dry Single Type (N/A)
	Brake		Wet, Multi-disc	Wet, Multi-disc
	Differential Lock		Standard	Standard
	Creeper		No	No
	Cruise Control		Standard	Standard
<b>Hydraulics</b>	Power Steering		Hydrostatic Power Steering	Hydrostatic Power Steering
	Total Hydraulic Flow (POWER STEERING+Implement)	gpm/ lpm	13.7 (4.4+9.3) / 51.9 (16.8+35.1)	13.7 (4.4+9.3) / 51.9 (16.8+35.1)
	Lift Control Type		Position	Position
	Joystick Valve		Standard	Standard
	Rear Remote(Port)		Optional (Up to 4)	Optional (Up to 4)

Specification		Models	5045H	5055H
3 Point Hitch	3 Point Hitch		CAT I	CAT I
	Lift capacity at lift link ends	lbs (kg)	3,306 (1,500)	3,306 (1,500)
	3Point Hitch Lift Capacity @24" behind lift point	lbs (kg)	2,425 (1,100)	2,425 (1,100)
PTO	Rear(Mid) PTO Speed	RPM	540 / 540E	540 / 540E
	Rear PTO Type		Independent	Independent
	Clutch		Wet, Multi-disc	Wet, Multi-disc
Tires	Front		9.5 - 16	9.5 - 16
	Rear		12.4 - 28	13.6 - 26
Dimensions	Wheelbase	in. (mm)	71.1 (1,806)	71.1 (1,806)
	Overall Length(W/ 3PT)	in. (mm)	127.4 (3,236)	127.4 (3,236)
	Min.Overall Width	in. (mm)	64.9 (1,650)	64.9 (1,650)
	Overall Height(W/ ROPS)	in. (mm)	98.4 (2,500)	98.4 (2,500)
	Ground Clearance(4WD)	in. (mm)	15.5 (394)	15.5 (394)
	Min.Turning Radius(W/ Brake)	feet (m)	9.18 (2.80)	9.18 (2.8)
	Turning Degree		45°	45°
	Weight(W/O Front Weights)	lbs (kg)	3,754 (1,703)	3,836 (1,740)

※ Specifications are subject to change without notice. Contact your local dealer for more information.

\*540E: Economic

## DRIVING SPEED

※ The tractor's speed is changed by the condition of the tires and road surface.

※ To ensure safety, drive at a proper speed.

Engine speed: 2,850 rpm, Tire SLR : 596 mm (Rear 13.6-26)

km/h (mph)

RANGE		A				B				C				D			
MAIN		1	2	3	4	1	2	3	4	1	2	3	4	1	2	3	4
SYNC.	FORWARD	1.719	2.015	2.704	3.107	3.470	4.068	5.457	6.270	7.408	8.684	11.648	13.385	15.583	18.265	24.501	28.153
	BACKWARD	1.607	1.927	2.408	2.971	3.243	3.890	4.860	5.996	6.924	8.305	10.375	12.800	14.563	17.468	21.822	26.924

RANGE		A				B				C				D			
HST	FORWARD	3.80				7.67				16.37				34.43			
	BACKWARD	3.80				7.67				16.37				34.43			

## 4. OPERATION DESCRIPTION

<b>EXTERIOR VIEW .....</b>	<b>4-3</b>	BATTERY CHARGE WARNING LAMP .....	4-14
CABIN .....	4-3	RPM GAUGE/ ENGINE USING HOUR METER.....	4-14
ROPS .....	4-4	FUEL GAUGE.....	4-14
<b>SWITCHES AND LEVERS .....</b>	<b>4-4</b>	PTO ROTATING POSITION.....	4-15
MEC .....	4-5	WATER TEMP GAUGE.....	4-15
HST .....	4-6	DPF LAMP.....	4-16
MAIN (IGNITION) KEY SWITCH .....	4-7	<b>CONTROLS 1(PEDALS) - MEC.....</b>	<b>4-18</b>
STEERING COLUMN TILT LEVER.....	4-7	CLUTCH PEDAL.....	4-18
F-R SHUTTLE LEVER.....	4-8	BRAKE PEDAL (LEFT/RIGHT).....	4-19
COMBINATION SWITCH .....	4-8	ACCELERATOR PEDAL .....	4-19
ACCELERATOR LEVER .....	4-10	<b>CONTROLS 1(PEDALS) - HST.....</b>	<b>4-20</b>
<b>INSTRUMENT PANEL .....</b>	<b>4-10</b>	BRAKE PEDAL (LEFT/RIGHT).....	4-20
TURN SIGNAL LAMP .....	4-12	F-R SHUTTLE PEDAL (HST).....	4-21
HIGH BEAM LAMP .....	4-12		
PTO LAMP.....	4-12		
ENGINE OIL PRESSURE WARNING LAMP .....	4-13		
PRE-HEAT LAMP.....	4-13		

## 4. OPERATION DESCRIPTION

<b>CONTROLS 2 .....</b>	<b>4-22</b>	<b>OTHERS .....</b>	<b>4-36</b>
JOY-STICK LEVER .....	4-26	STORAGE COMPARTMENT /	
MAIN SHIFT LEVER .....	4-27	CIGARETTE LIGHTER SOCKET .....	4-36
POSITION CONTROL LEVER .....	4-28	SEAT BELT .....	4-37
SCV LEVER .....	4-28	SEAT ADJUSTMENT .....	4-37
RANGE SHIFT LEVER .....	4-28	SAFETY FRAME ROPS .....	4-38
PARKING BRAKE LEVER .....	4-29	BRAKE LAMP .....	4-39
MFWD LEVER .....	4-30	WORK LAMP (ROPS) .....	4-39
PTO SHIFT LEVER .....	4-30		
FLOW CONTROL VALVE .....	4-31		
DIFFERENTIAL LOCK PEDAL .....	4-31		
PTO OPERATION SWITCH .....	4-32		
CRUISE CONTROL SWITCH .....	4-32		
DPF REGENERATION SWITCH .....	4-33		
HAZARD SWITCH .....	4-34		
WORK LAMP SWITCH .....	4-34		
WIPER SWITCH .....	4-35		
AIR CONDITIONER .....	4-35		

## EXTERIOR VIEW [CABIN]

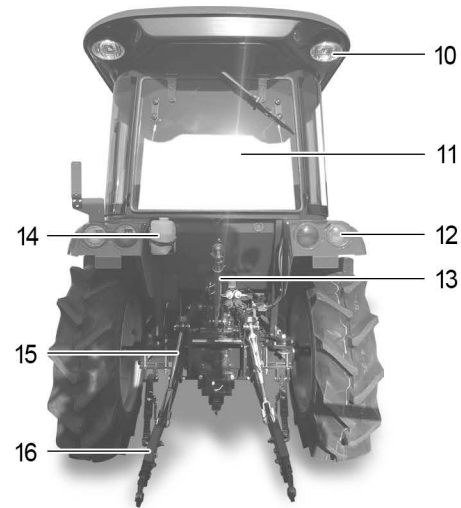
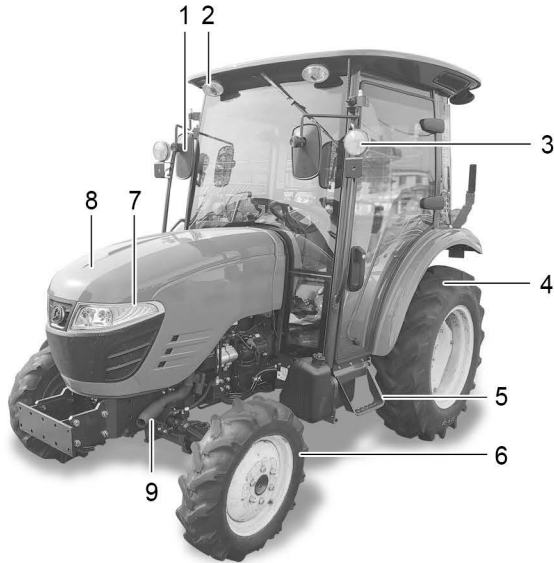

- (1) Side Mirror
- (2) Working Lamp (Front)
- (3) Turn Lamp
- (4) Rear Tire
- (5) Step
- (6) Front Tire

- (7) Head Lamp
- (8) Hood
- (9) Muffler
- (10) Working Lamp (Rear)
- (11) Rear Window
- (12) Rear Combination Lamp

- (13) Top Link
- (14) Washer Tank
- (15) Lift Rod
- (16) Lower Link

[ROPS]

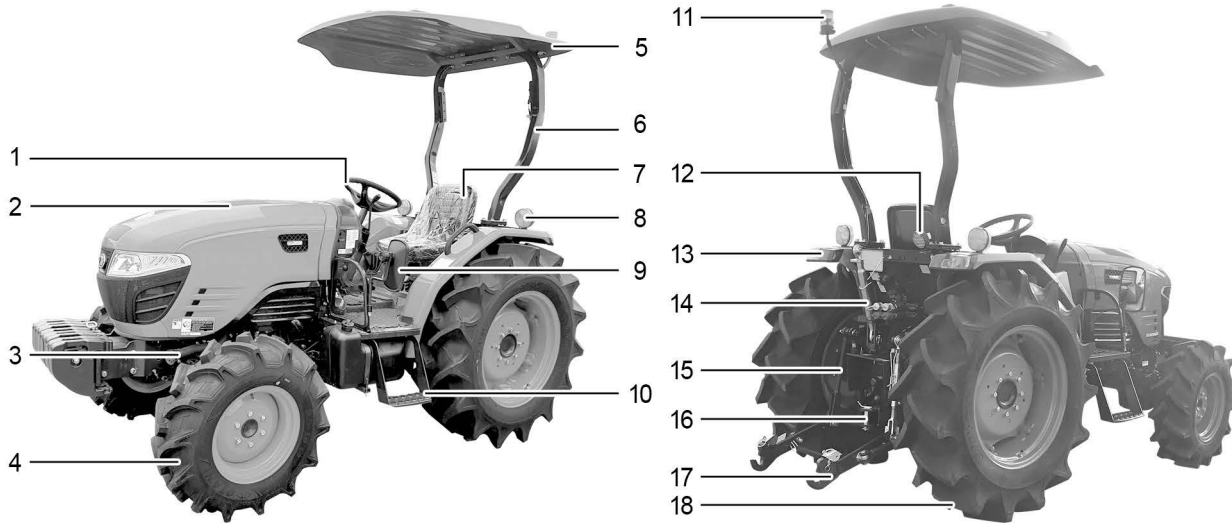

- (1) Steering Wheel (Handle)
- (2) Hood
- (3) Muffler
- (4) Front Tire
- (5) Sun Visor (Option)
- (6) Safety Frame

- (7) Seat
- (8) Turn Lamp
- (9) Side Mirror
- (10) Step
- (11) Working Lamp
- (12) LED Working Lamp

- (13) Combination Lamp
- (14) Top Link
- (15) Lift Link
- (16) Draw Bar
- (17) Lower Link
- (18) Rear Tire

## SWITCHES AND LEVERS [MEC.]



- (1) Steering Wheel (Handle)
- (2) F-R Shuttle Lever
- (3) Combination Switch
- (4) Steering Column Tilt Lever
- (5) Accelerator Lever
- (6) Main (Ignition) Key Switch

※ Refer to the relevant content for further detailed information



[HST]



- (1) Steering Wheel (Handle)
- (2) Combination Switch
- (3) Steering Column Tilt Lever
- (4) Accelerator Lever
- (5) Main (Ignition) Key Switch

※ Refer to the relevant content for further detailed information

## MAIN (IGNITION) KEY SWITCH

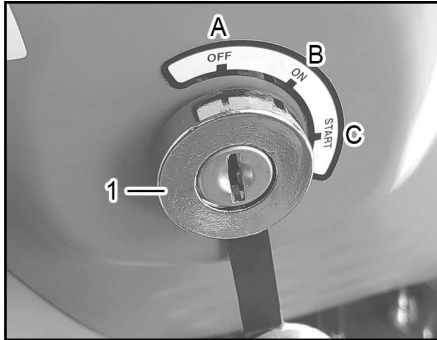

(1) Main (Ignition) Key Switch  
 (A) OFF (B) ON (C) START

The main (ignition) key switch is used to start or stop the engine.

- OFF: The engine is stopped, and current ends at the main (ignition) key switch.
- ON: Electric current flows to all switches in the electrical system.
- START: When the starter motor is engaged, the engine will start. When the engine is started, release the key. The key will return to the “ON” position automatically and the engine will keep running.

### CAUTION

- To start the engine, put the shuttle shift lever to the “Neutral” position to release the safety start system.

### CAUTION

- When the tractor is not in use, take out the key and keep it in a safe place.

## STEERING COLUMN TILT LEVER

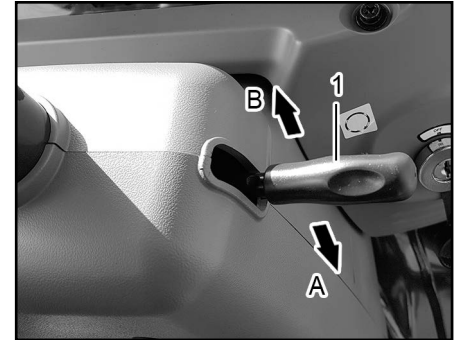

(1) Steering Column Tilt Lever  
 (A) Release (B) Lock

Confirm that the steering wheel is firmly fixed.

### CAUTION

- Must not be adjusted while driving.

## F-R SHUTTLE LEVER

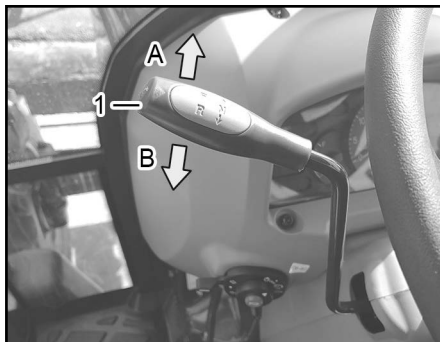

(1) F-R Shuttle Lever  
 (A) Forward (B) Reverse

This is used to drive the tractor forward or backward. Shift the lever with the clutch pedal and brake pedal depressed to maximum.

### ⚠ CAUTION

- For safety, when shifting from “forward” to “reverse” or from “reverse” to “forward”, put the lever in the “neutral” position and wait for the tractor to stop moving before shifting the gear to the opposite direction. To ensure safety, the lever must first be pulled upward for shifting to another position.

## COMBINATION SWITCH ▶ TURN SIGNAL LAMP SWITCH

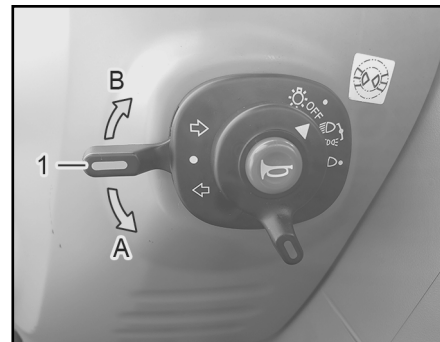

(1) Turn Signal Lamp Switch  
 (A) LH (B) RH

The turn signal lamps can be operated with the main (ignition) key switch in the “ON” position.

- Left turn: Turn the turn signal switch counterclockwise. Then, the left turn signal lamp and the left turn signal lamp on the instrument cluster blink.
- Right turn: Push the turn signal switch clockwise. Then, the right turn signal lamp and the right turn signal lamp on the instrument cluster blink.

**NOTE**

- This switch is not automatically returned to the neutral position. Therefore, set it back to the neutral position after turn.

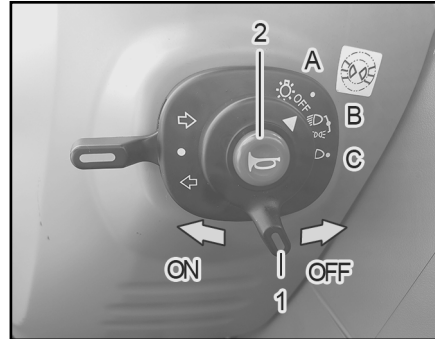
**► LAMP / HORN SWITCH**

- (1) Lamp Switch  
 (2) Horn Switch  
 (A) OFF  
 (B) Low  
 (C) High

The lamp switch can be operated with the main (ignition) key switch in the “ON” position.

「OFF」 - All light OFF

☰ - Instrument lamp, tail lamp and high beam lamp ON.

**⚠ WARNING**

- The high beam can obstruct the view of other drivers coming in the opposite direction on a road, leading to an unexpected accident.

The horn can be operated with the main (ignition) key switch in the “ON” position regardless of the light switch.

- Operating: Pressing the switch sounds the horn.

## ACCELERATOR LEVER

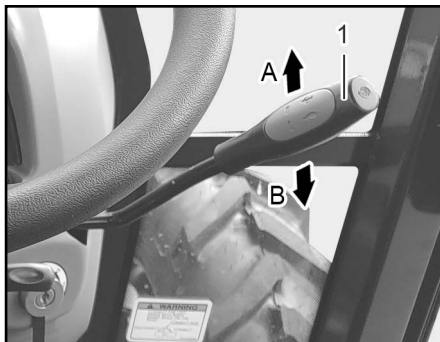

(1) Accelerator Lever

☝ : Slower Engine RPM (A)

☞ : Faster Engine RPM (B)

It is used to make the engine run faster or slower. It is also used when working at a constant speed.

### NOTE

- Use the foot throttle pedal during driving for travel, not the accelerator lever.

## INSTRUMENT PANEL

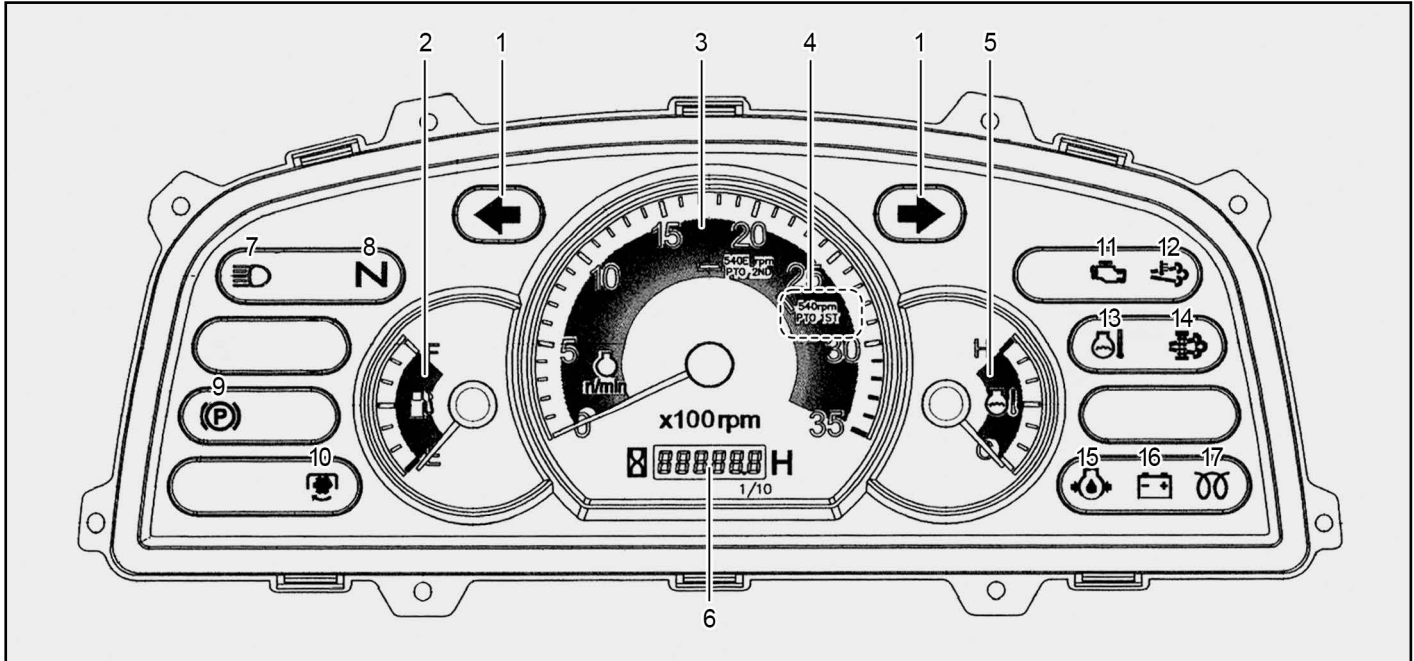

- |                               |                          |  |                    |
|-------------------------------|--------------------------|--|--------------------|
| (1) Turn Signal Lamp          | (7) High beam Lamp       | (13) Coolant Overheating<br>Warning Lamp | (17) Pre-heat Lamp |
| (2) Fuel Gauge                | (8) Neutral Lamp         | (14) DPF Lamp                            |                    |
| (3) Tachometer                | (9) Parking Brake Lamp   | (15) Engine Oil Pressure<br>Warning Lamp |                    |
| (4) PTO Rotating Position     | (10) PTO Lamp            | (16) Battery Charge Warning Lamp         |                    |
| (5) Coolant Temperature Gauge | (11) Engine Failure Lamp |  |                    |
| (6) Hour Meter                | (12) EGT Lamp            |  |                    |

### TURN SIGNAL LAMP

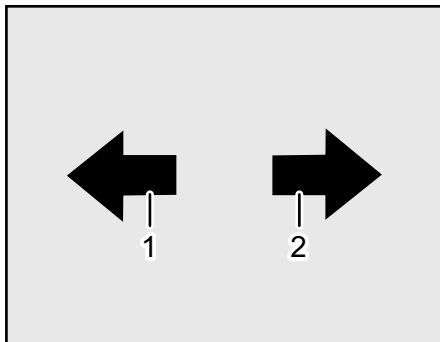

- (1) Left Turn Signal Lamp
- (2) Right Turn Signal Lamp

This lamps the condition when operating one of the turn signal lamps for the desired turning direction.

### HIGH BEAM LAMP

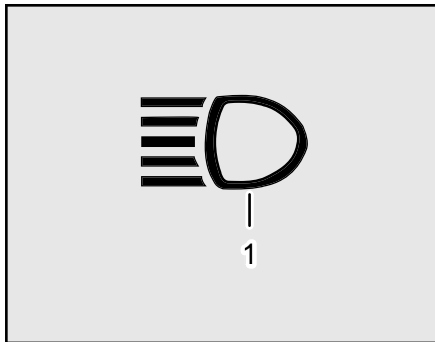

- (1) High Beam Lamp

Indicates the head lamps beam's position. It will come on when the high beam lamps are on High beam. On the contrary, if the head lamps are in the low beam, this lamp will not be lit.

### PTO LAMP

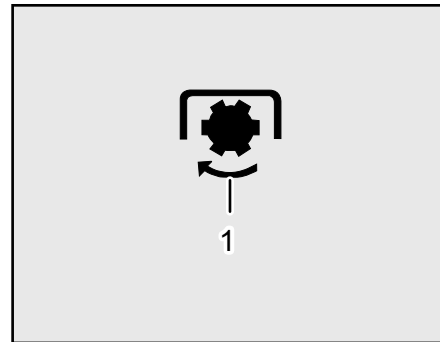

- (1) PTO Lamp

PTO lamp will light up when PTO ON/OFF switch is turned on.

## ENGINE OIL PRESSURE WARNING LAMP

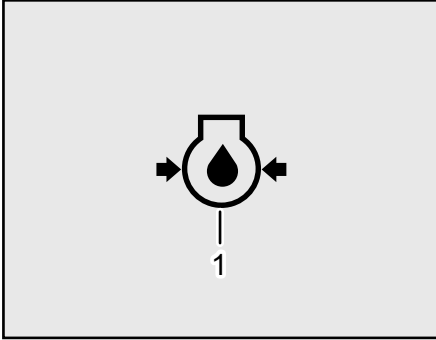

(1) Engine Oil Pressure Warning Lamp

Lamp will come on when the main (ignition) key switch is put into the "ON" position. It will turn off when the engine is started. If this lamp comes on while the engine is running, it indicates a problem in the engine oil system. Stop the engine immediately and check for problems.

## PRE-HEAT LAMP

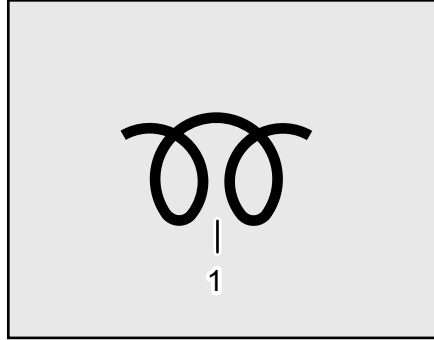

(1) Pre-heat Lamp

Lamp will light on/off depending on temperature of engine coolant when main (ignition) switch is turned on.

Lamp will be turned off when heater coil is heated. Start engine after this lamp is turned off.

It is difficult to start engine in winter when starting engine before warm up lamp is turned off. It also causes early discharge of battery.

### NOTE

- The time of pre-heating duration varies depending on the coolant temperature.

	Temperature	Time (sec.)
Lamp Time	above 104°F	less than 4
	5°F ~ 104°F	10
	less than 5°F	14



### BATTERY CHARGE WARNING LAMP

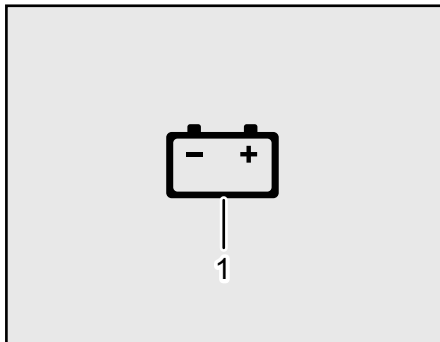

(1) Battery Charge Warning Lamp

It will be turned on when the main (ignition) switch is put into the "ON" position, and will be turned off when the battery starts being charged after engine is started and the engine revolution increases.

The battery will not be charged with the engine below 1,000 rpm. (The rpm should be 1,500 rpm or higher)

### RPM GAUGE /ENGINE USING HOUR METER

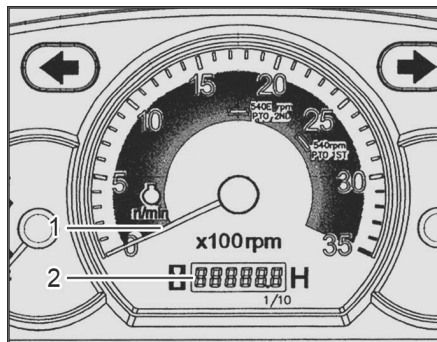

(1) RPM Gauge  
(2) Engine Hour Meter

The needle indicates the number of engine RPM. It indicates the tractor's running hours. By multiplying the digit in the far right position by 6, you will get the time in minute.

### FUEL GAUGE

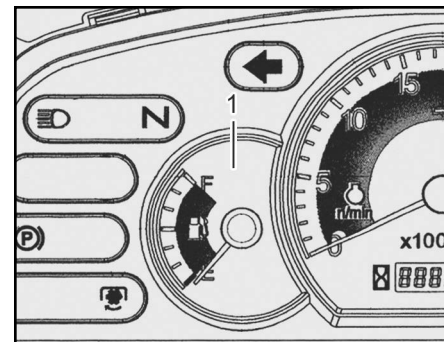

(1) Fuel Gauge

This indicates the remaining fuel level. Immediately fill the fuel tank if the needle reads the red area.

## PTO ROTATING POSITION

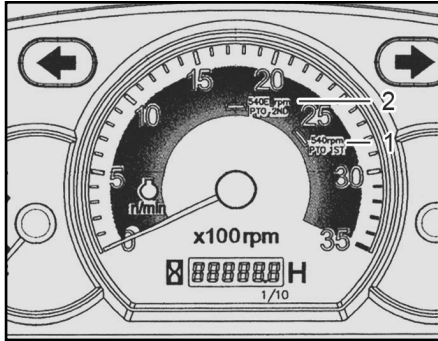

- (1) PTO Rotating Position (1<sup>st</sup> Stage)  
 (2) PTO Rotating Position (2<sup>nd</sup> Stage)

They indicate required engine RPM for specific PTO rotating positions.

POSITION	PTO RPM	ENGINE RPM
1 <sup>st</sup> stage	540	2,600
2 <sup>nd</sup> stage	540E*	1,800

\*540E: Economic

## COOLANT TEMP GAUGE

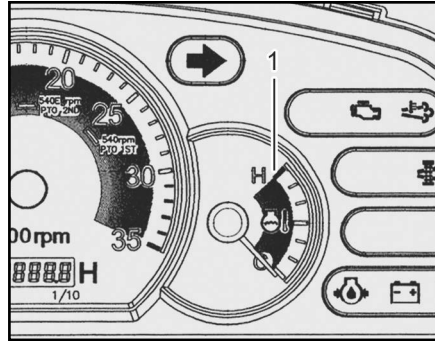

- (1) Coolant Temperature Gauge

The needle indicates the temperature of the engine coolant during running. If the needle is in the red zone, stop running the engine and check for problems.

## DPF LAMP

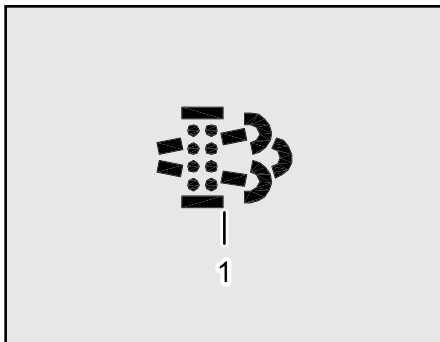

(1) DPF Lamp

The lamp is used to alarm user when DPF should be cleaned or there is a problem with temperature/pressure sensor.



### CAUTION

- Continuing to drive with the DPF lamp illuminated, it can lead to severe damage to the DPF.

### NOTE

#### Actions for DPF lamp illumination

#### 1. EMERGENCY

Lamp illuminated during driving:  
Stop the vehicle and engine and contact your dealer for assistance.









#### 2. CAUTION



Lamp blinking at 0.5 sec. intervals:  
Have your workshop check the sensor.

#### 3. CHECK

Lamp blinking at 2 sec. intervals:  
Have your workshop clean the DPF.

## ► SENSOR ERROR INDICATION &amp; CORRECTIVE ACTION

Items	Lamp Indication	Description
RPM error		Light on Activates when the rpm signal is not input for cranking.
Water temperature sensor error		Light on Activates when the water temperature sensor is out of range.
Differential pressure sensor error		Repeat blinking twice every 2.5 sec. Active when the differential pressure sensor is out of range.
Learning error of electric exhaust valve		0.5 sec. Blinking + 2 sec. Blinking Repeat the above pattern Active when the position of the electronic exhaust valve is not learned. The lamp continues to be blinked until the learning of the electronic exhaust valve is successful.
Working error of electric exhaust valve		Blinking Active when the position sensor of the electronic exhaust valve is out of the range.
DPF error		Light on Active when the DPF is damaged or removed.
Glow relay error		0.5 sec. Blinking Glow Relay (Pin 25) Disconnection or Relay fault Lights up for more than 2 sec.
Cooling water overheat		Light on When the cooling water temperature is 110 degrees or higher option) HA00001566A instrument panel only.

1) Engine warning lamp  = 

2) Cleaning logic (30% close operation of valve, prevention of valve seizure) is present at every key-on.

## CONTROLS 1(PEDALS) [MEC.]



- (1) Clutch Pedal
- (2) Brake Pedal
- (3) Accelerator Pedal

## CLUTCH PEDAL

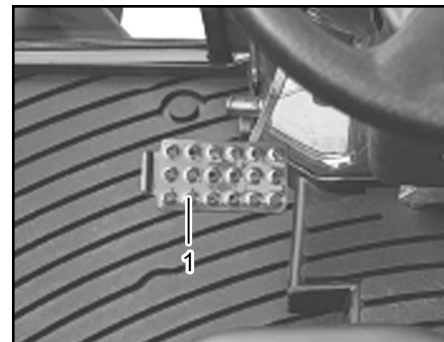

- (1) Clutch Pedal

If the clutch pedal is depressed, driving power is stopped supplying. When the clutch pedal is depressed, the main/range shift lever can be operated. To start off smoothly, release the clutch pedal slowly.

## BRAKE PEDAL (LEFT/RIGHT)

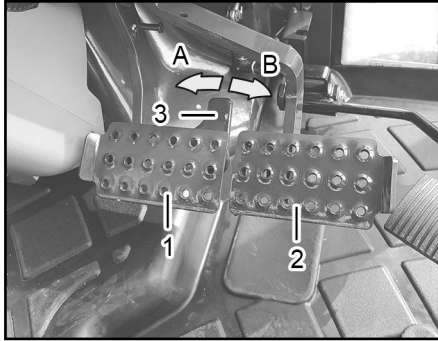

- (1) Left Brake Pedal    (2) Right Brake Pedal  
 (3) Link Bracket  
 (A) Release            (B) Engage

Each brake pedal is activated independently. To make a sharp turn, depress one of the brake pedals on the turning direction to brake the rear wheel on the same side.

Make sure to interlock the brake pedals with the link bracket before driving on a public road.



### CAUTION

- Be sure to connect the left and right brake pedals with the connecting brackets when traveling.



### WARNING

- Connect the left and right brake pedals while driving on a road, loading/unloading the vehicle or driving into/out of a field to avoid rollover and collision.
- Check the left and right brakes periodically so that they can be operated simultaneously.

## ACCELERATOR PEDAL

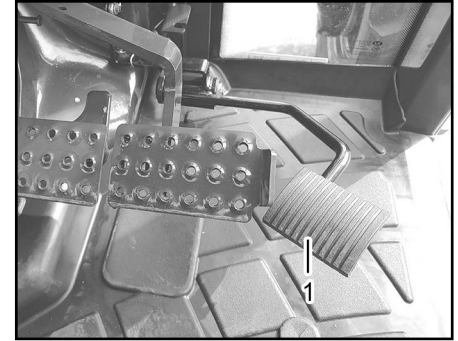

- (1) Accelerator Pedal

It is used to make the engine run faster or slower. It is usually used when driving on a road. (Mec. transmission only)

## CONTROLS 1(PEDALS) [HST]



- (1) Brake Pedal
- (2) Forward Shuttle Pedal
- (3) Reverse Shuttle Pedal

## BRAKE PEDAL (LEFT/RIGHT)

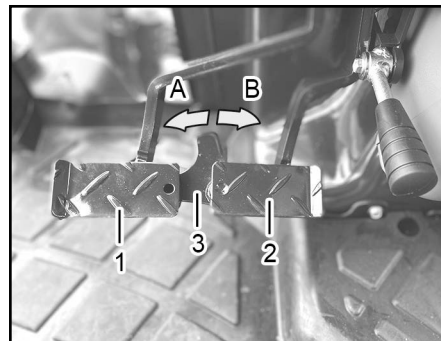

- (1) Left Brake Pedal
- (2) Right Brake Pedal
- (3) Link Bracket
- (A) Engage
- (B) Release

Each brake pedal is activated independently. To make a sharp turn, depress one of the brake pedals on the turning direction to brake the rear wheel on the same side.

Make sure to interlock the brake pedals with the link bracket before driving on a public road.

## F-R SHUTTLE PEDAL (HST)

### CAUTION

- Be sure to connect the left and right brake pedals with the connecting brackets when traveling.

### WARNING

- Connect the left and right brake pedals while driving on a road, loading/unloading the vehicle or driving into/out of a field to avoid rollover and collision.
- Check the left and right brakes periodically so that they can be operated simultaneously.



- (1) Forward Shuttle Pedal
- (2) Reverse Shuttle Pedal

It is used for shifting between “forward” and “reverse” drive. And stay pedals at neutral machine should be stopped.

### CAUTION

- For safety, do not shift quickly from “forward” to “reverse” or from “reverse” to “forward”. Engage Brake pedals when stopping the machine for machine to stop quickly.



## CONTROLS 2 - CABIN LEVER OPERATION (LH)

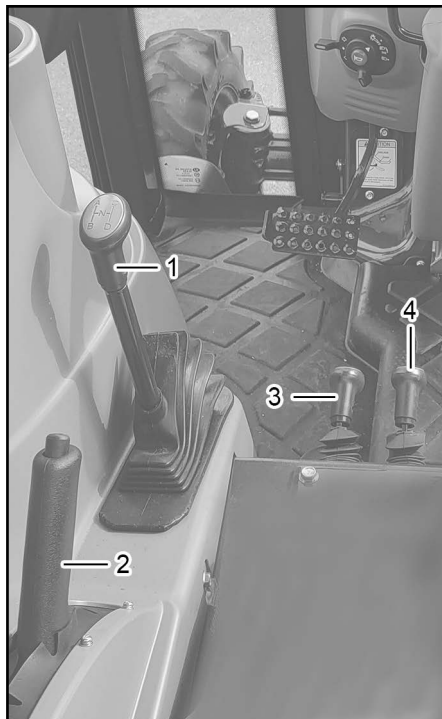

- (1) Range Shift Lever
- (2) Parking Brake Lever
- (3) PTO Shift Lever
- (4) MFWD Lever

## SWITCHES AND LEVERS (RH)



- (5) Joy-Stick Lever
- (6) Main Shift Lever
- (7) Position Control Lever
- (8) DPF Regeneration Switch
- (9) Hazard Switch
- (10) PTO Operation Switch
- (11) SCV Lever I
- (12) SCV Lever II

## CONTROLS 2 - CABIN/HST LEVER OPERATION (LH)



- (1) Range Shift Lever
- (2) PTO Shift Lever
- (3) MFWD Lever
- (4) Parking Brake Lever

## SWITCHES AND LEVERS (RH)

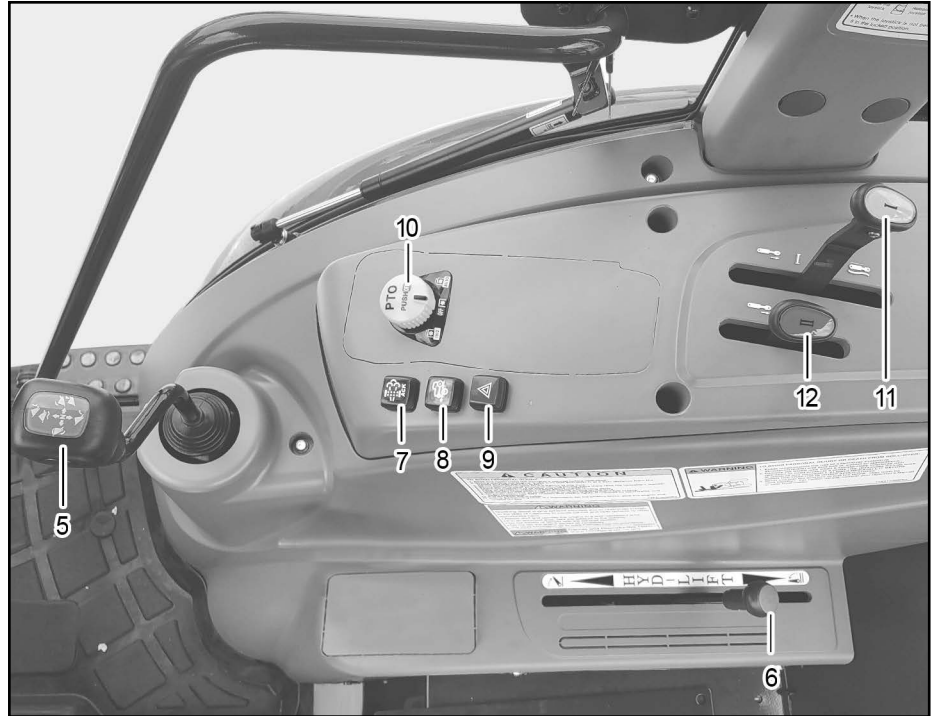

- (5) Joy-Stick Lever
- (6) Position Control Lever
- (7) DPF Regeneration Switch
- (8) Cruise Control Switch
- (9) Hazard Switch
- (10) PTO Operation Switch
- (11) SCV Lever I
- (12) SCV Lever II

## CONTROLS 2 - ROPS LEVER OPERATION (LH)

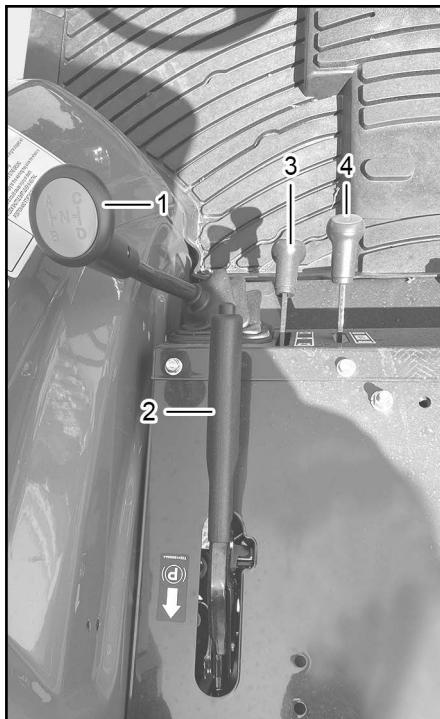

- (1) Range Shift Lever
- (2) Parking Brake Lever
- (3) PTO Shift Lever
- (4) MFWD Lever

## SWITCHES AND LEVERS (RH)

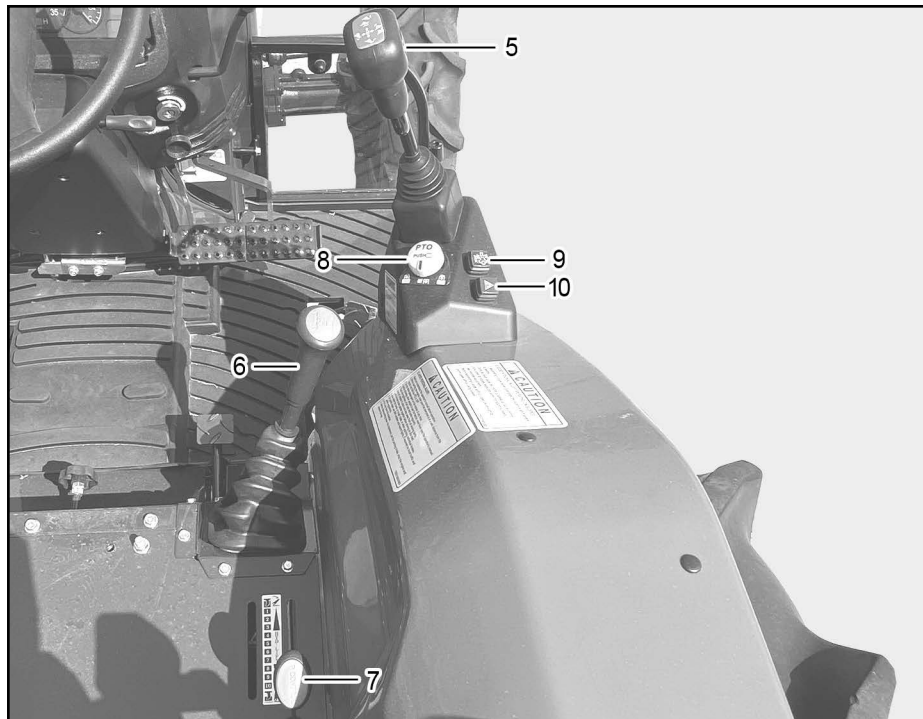

- (5) Joy-Stick Lever
- (6) Main Shift Lever
- (7) Position Control Lever
- (8) PTO Operation Switch
- (9) DPF Regeneration Switch
- (10) Hazard Switch

## CONTROLS 2 - ROPS/HST LEVER OPERATION (LH)

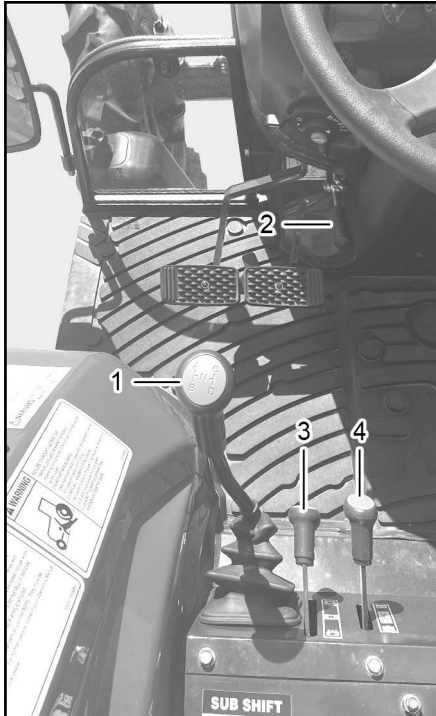

- (1) Range Shift Lever
- (2) Parking Brake Lever
- (3) PTO Shift Lever
- (4) MFWD Lever

## SWITCHES AND LEVERS (RH)

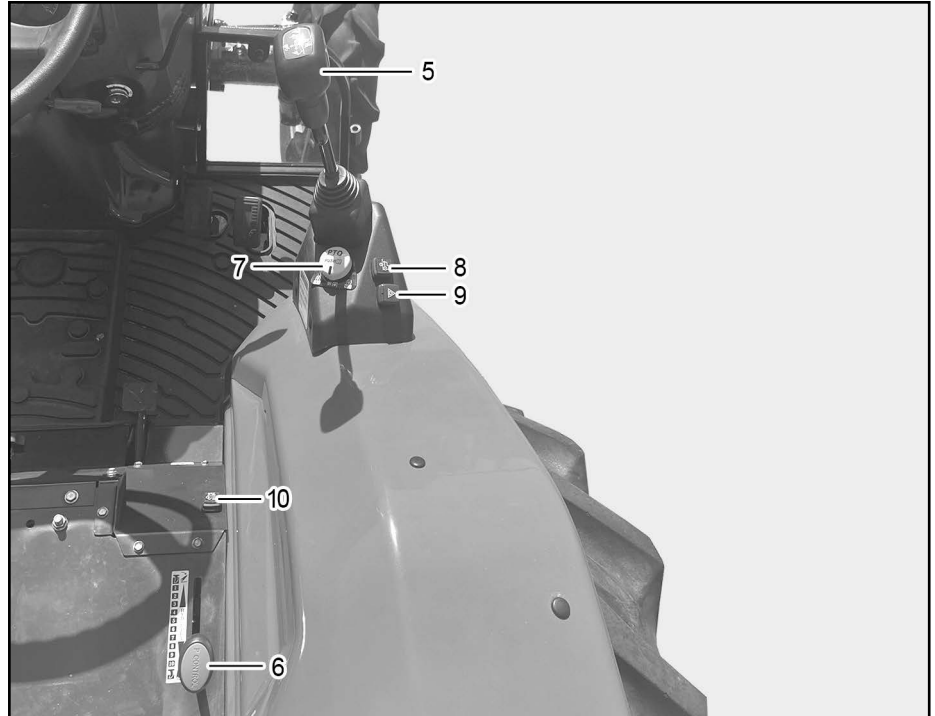

- (5) Joy-Stick Lever
- (6) Position Control Lever
- (7) PTO Operation switch
- (8) Cruise Control Switch
- (9) Hazard Switch
- (10) DPF Regeneration Switch

## JOY-STICK LEVER

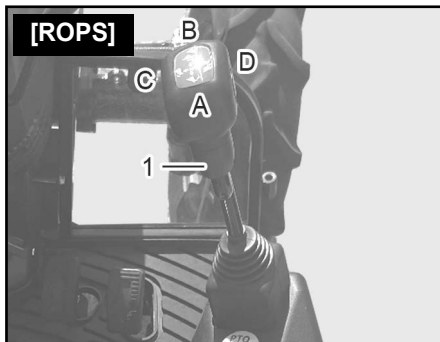
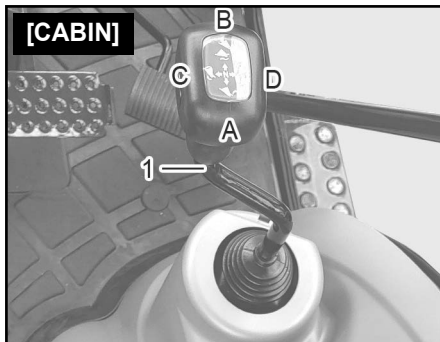

(1) Joy-Stick Lever

It is a device that allows control during loader operation.

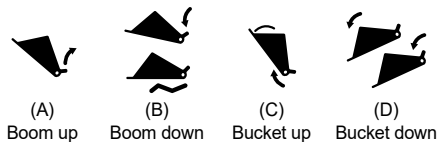

### NOTE

- Do not operate the boom cylinder and bucket cylinder at the same time. A loader may malfunction due to insufficient oil flow.

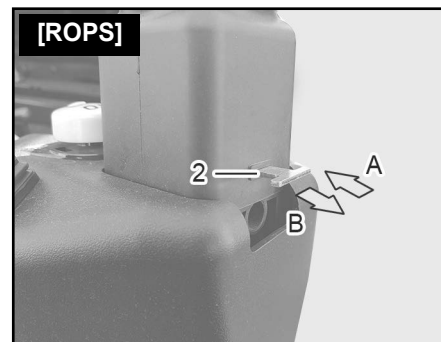
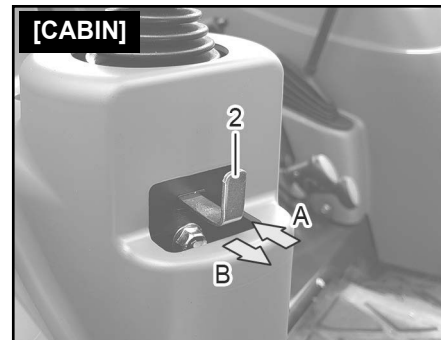

(2) Lock Button

(A) Lock

(B) Release

## MAIN SHIFT LEVER

There is a button to lock the operation of the joystick lever. Pulling it forwards unlocks the lever while pushing it backwards locks the lever.

### WARNING

- Make sure to set the joystick lever in the neutral position and press the lock button to lock the lever in that position when the lever is not in use. Otherwise, an implement may fall accidentally by unintended operation of the lever.

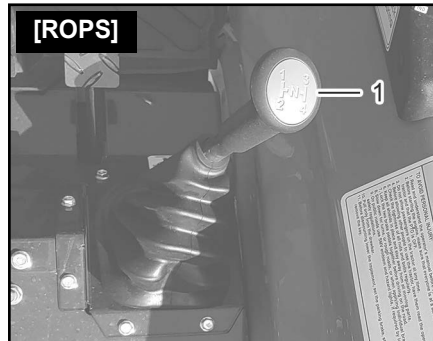
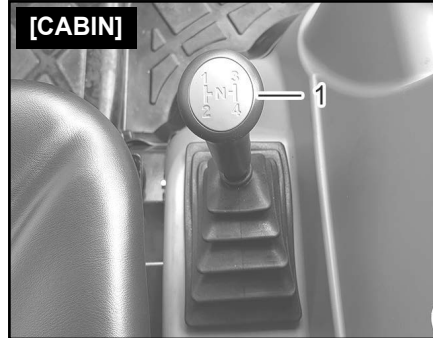

(1) Main Shift Lever

Four speeds can be selected by moving this main shift lever in “H” shaped path.

The driving speed can be shifted from the 1st to 4th gears. When shifting the gears depress the clutch fully.

### POSITION CONTROL LEVER

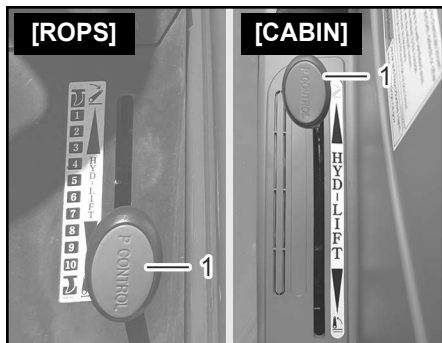

(1) Position Control Lever

It is used to keep the implement constantly at a certain position.

A stopper is used to fix the position control lever in the “UP” position while driving on a road.

When lowering the implement, set the position control lever, and the implement will go down to the set position.

### SCV LEVER



(1) SCV Lever (I)  
(2) SCV Lever (II)

It is used to for the rear implement hydrostatic.

LEVER #	I	II
DETENT	N/A	REAR

### RANGE SHIFT LEVER

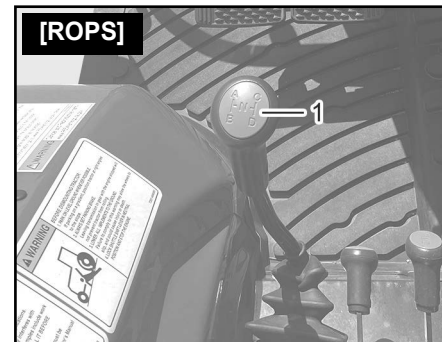
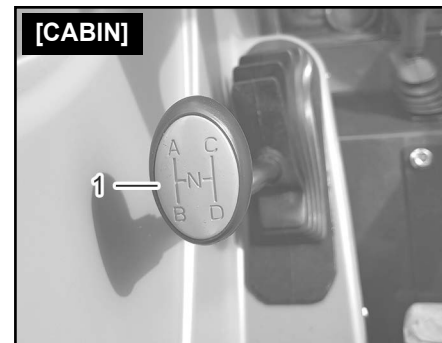

(1) Range Shift Lever

## PARKING BRAKE LEVER

The range gear is shifted in four levels (A-B-C-D). The combination with the main gear provides 16 stages (4 stages: HST only) of gear shifting. When shifting the range gear, Operator must stop the tractor.

### NOTE

- Operate the range shift lever only after the tractor is completely stopped. Shifting the lever during driving can damage the gears.

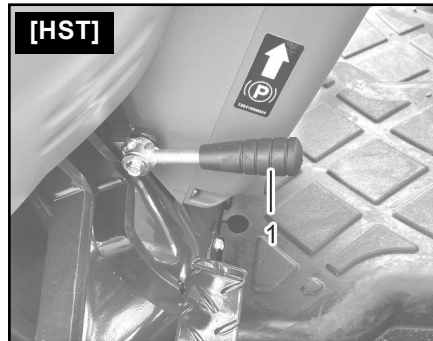
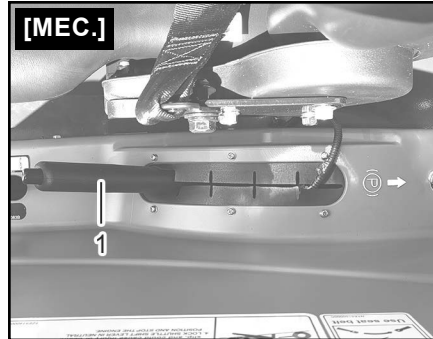

Pull the lever up while depressing the Brake pedal fully to engage the parking Brake.

To release the parking Brake, step on the Brake pedal and push the lever down.

Connect both Brake pedals with the coupler.

(1) Parking Brake Lever



## MFWD LEVER

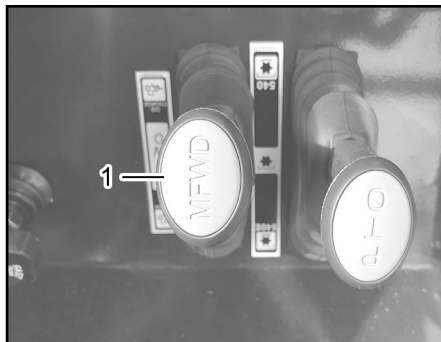

(1) MFWD Lever

It is used to shift between 2-wheel drive and 4-wheel drive. Depress the clutch pedal when shifting the lever.

## PTO SHIFT LEVER

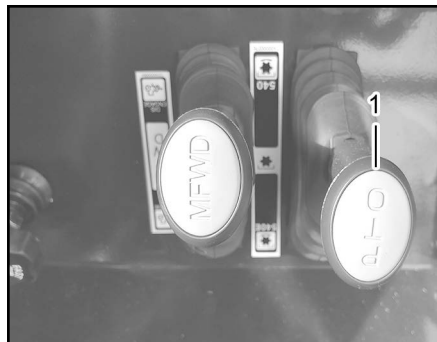

(1) PTO Shift Lever

The revolution of the PTO shaft can be shifted in two stages. When shifting stage, press PTO Operation Switch to "OFF" position.

PTO POSITION	PTO RPM
1 <sup>st</sup> stage	540
2 <sup>nd</sup> stage	540E*

\*540E: Economic

### CAUTION

- Observe the PTO speed designated on the implement. Otherwise, the implement may be damaged and cause an accident.
- Operate the PTO shift lever only after setting the PTO ON/OFF switch to the "OFF" position.

### WARNING

- To avoid personal injury, Confirm that no one or a foot is under the implement before operating the system.

## FLOW CONTROL VALVE

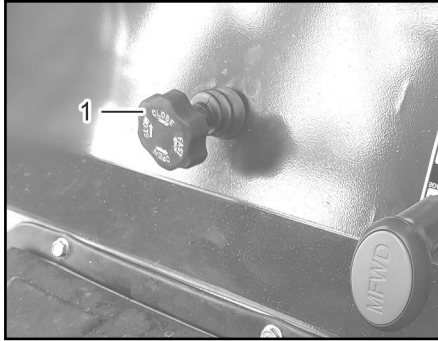

(1) Flow Control Valve

It is used to regulate the lowering speed of the implement (slow return function). Also, if you wind the valve fully to the right, the hydraulic pressure to the device raising the implement is stopped.

### WARNING

- Do not work under or put a foot under the implement.

[Otherwise]

The implement may fall and cause an injury.

## DIFFERENTIAL LOCK PEDAL

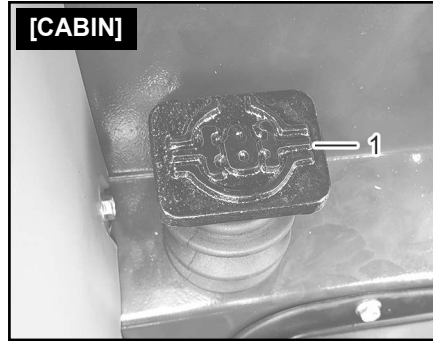

(1) Differential Lock Pedal

It is used to transmit the same power to both rear wheels and serves to prevent slipping when one of the rear wheels is idling.

### WARNING

- Release the differential lock when making a turn. Otherwise, the tractor may not turn in the direction you want and cause an accident.

### CAUTION

- Never lock the differential when driving on a road.

[Otherwise]

Driving will be unstable and the tractor may cause an accident.

## PTO OPERATION SWITCH

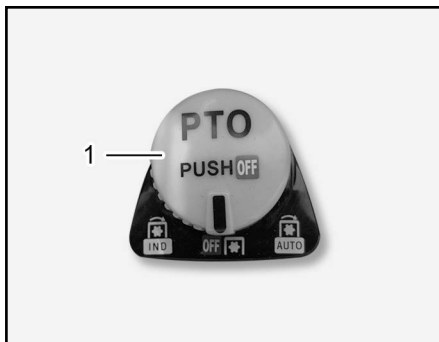

(1) PTO Operation Switch

### ► [IND]

In the IND position, the PTO shaft rotates constantly regardless of the position of the rear implement or connection status of the clutch.

### ► [AUTO]

In the AUTO position, the PTO shaft stops rotation when the rear implement is lifted to a certain level. The PTO shaft rotates again as soon as the rear implement is lowered.

### ► [AUTO - MEC. MODEL]

When the implement is lifted to the preset height or the clutch pedal is depressed, the PTO shaft is automatically stopped.

The PTO shaft rotates again as soon as the rear implement is lowered or the clutch pedal is released.

### ► [OFF]

PTO does not rotate. When not working, put to this position.

※The engine does not start up, when the PTO clutch is in "IND" or "LINK". Put to "OFF" position for starting up the engine.

## CRUISE CONTROL SWITCH

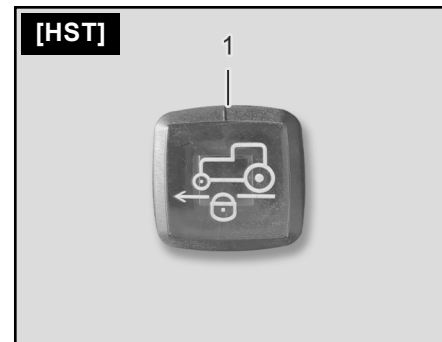

(1) Cruise Control Switch

1. When the machine has reached the desired speed, press cruise control switch to "ON". Release the F-R shuttle pedal and the machine will operate at the selected speed.
2. When applying full pressure to the Brake pedals, the cruise control will be deactivated and it will be necessary to reset the cruise control to the desired speed.

3. When applying light pressure to the Brake pedals, the machine's ground speed will be reduced until the Brake pedals are released. At that point the machine will continue at the previous setting.
4. To reset the desired speed, you should turn off the cruise control switch, then increase machine speed to reach the desired speed and push the cruise switch to on.

### CAUTION

- When stopping the machine cruise control keep machine stop status.
- Make sure to connect both Brake pedals when using cruise control function.

#### [Otherwise]

There is a risk abrupt turning or over-turning due to one-sided braking when the Brake pedal is depressed.

## DPF REGENERATION SWITCH



(1) DPF Regeneration Switch

Holding the button down for more than 3 seconds initiates regeneration; the lamp turns off in 30 minutes when automatic regeneration is complete.

The DPF (Diesel Particulate Filter) collects soot contained in the engine exhaust and reduces exhaust smoke. The soot collected in the filter must be burned periodically to prevent the filter from clogging and to ensure that the filter can continue collecting soot. The DPF is regenerated by increasing the back pressure in the engine and raising the temperature of the exhaust.

## HAZARD SWITCH



(1) Hazard Switch

Press the hazard switch in emergency to warn other vehicles in order to prevent an accident.

Pressing this switch blinks all turn signal lamps regardless of the position of the main (ignition) key switch. Pressing it again disables the flasher function.



### CAUTION

- Prolonged operation can consume electricity excessively. Therefore, use it only in emergency. Use it only when necessary as it can discharge the battery and obstruct other driver's view.

## WORK LAMP SWITCH

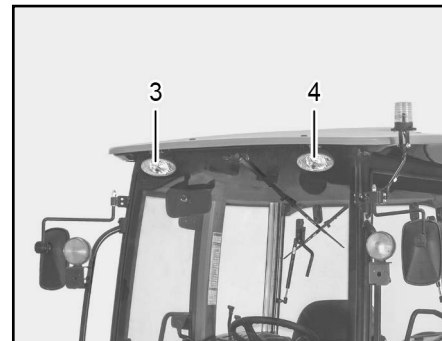
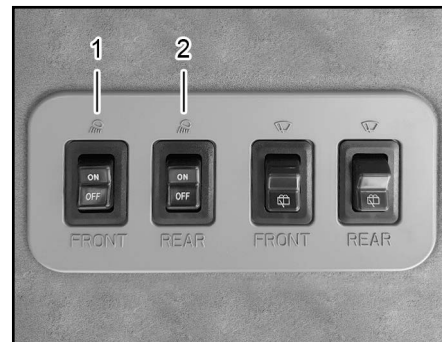

- (1) Work Lamp Switch (FR)
- (2) Work Lamp Switch (RR)
- (3) Work Lamp (RH)
- (4) Work Lamp (LH)

It is used to turn on work lamps on the top roof.

## WIPER SWITCH

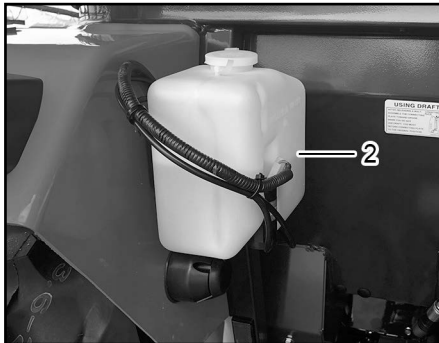
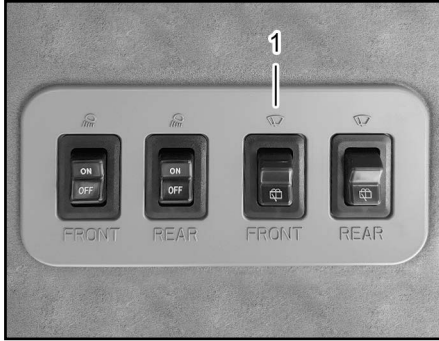

- (1) Wiper Switch  
(2) Window Washer Fluid Reservoir Tank

Wiper blades will operate when upper buttons of wiper switch are pressed.

Washer fluid is sprayed on to windshield and the wipers are operated when buttons are pressed once more.

Lower buttons will only spout wash liquid. Wash liquid tank for cleaning is located on rear left side of cab exterior.

### CAUTION

- Do not use the wiper when the washer fluid reservoir is empty, otherwise you will damage the washer pump.
- Do not use the wiper if there is any danger that the fluid will freeze on the wind-shield. If you do, your vision could be obscured. For this reason, use washer fluid.

## AIR CONDITIONER

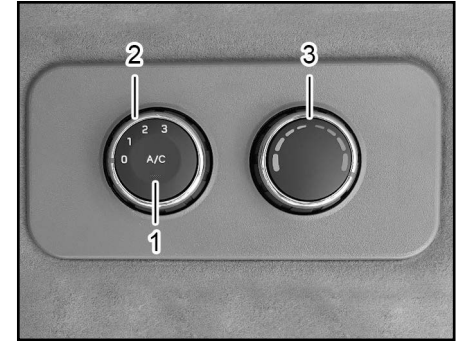

- (1) Cooling Function (2) Air Flow Rate  
(3) Temperature

### ► COOLING FUNCTION

When the cooling function is on, the air compressor is worked, then reheated according to the temperature setting.

### ► AIR FLOW RATE

Adjust the air flow rate. The higher the rate, the more effective the heating or cooling will be.

## OTHERS STORAGE COMPARTMENT / CIGARETTE LIGHTER SOCKET

### ► AIR CIRCULATE CONTROL

Used to shift the supply of outside air and recirculates the inside air.

### ► TEMPERATURE:

- Red, to increase the temperature.
- Blue, to decrease the temperature.

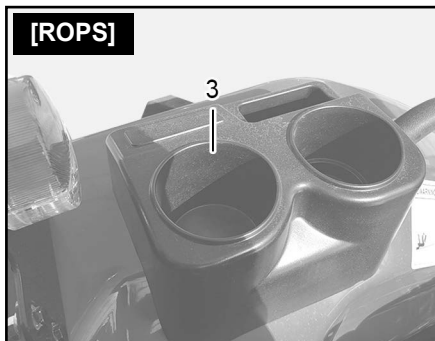

- The cup holder and storage compartment are separated.(only cabin)
- There is a cigarette lighter socket for power connection of the electronic device. (12V)

- (1) Storage Compartment
- (2) Cigarette Lighter Socket
- (3) Cup Holder

## SEAT BELT



(1) Seat Belt



### CAUTION

- Set the chair to the position of driver's post and keep your upper body upright. Fit the belt around your waist and fit the buckle until it clicks into place. To release, press the "PRESS" button on the buckle.

[Otherwise]

There is a risk of death or serious injury if the rollover occurs.

## SEAT ADJUSTMENT



### ► FORE AND AFT POSITIONING

Lift handle and move the seat forward or rearward. Release the handle at one of several positions.



### WARNING

- Do not wear the seat belt when the safety frame is folded down. With the frame folded down, it does not provide safety.
- When operating the tractor, make sure to keep the safety frame in the upright position and wear the seat belt.



## SAFETY FRAME ROPS

### ► BACK CUSHION ANGLE ADJUSTMENT

Lift the handle and let the back cushion spring forward, or lean backward into the cushion. Release the handle at desired position.

### ► WEIGHT ADJUSTMENT

With seat in mid-position, extend the crank lever from knob and rotate minus(-) direction for less support or Plus(+) for more support. Use the lamp for approximate weight setting. Release crank lever.

### CAUTION

- **Never attempt to adjust your seat while the tractor is moving. The seat could respond with unexpected movement, and the ensuing loss of tractor control could lead to an accident.**



The safety frame is intended to reduce damage of an accident in case of a rollover, so it cannot prevent an accident.

Always have the safety frame installed securely for driving to ensure your safety unless going under an area with a low ceiling such as a garage.

### WARNING

- **If a rollover accident occurs without the safety frame, the frame cannot protect the driver, leading to a severe injury or even death. Never drive with the safety frame detached.**

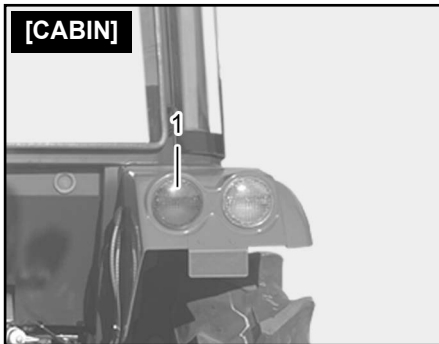
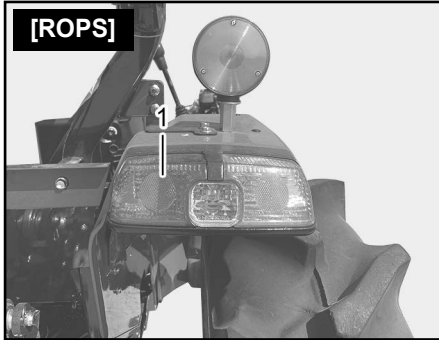
**BRAKE LAMP**

(1) Brake Lamp

It is turned on when the Brake pedal is depressed.

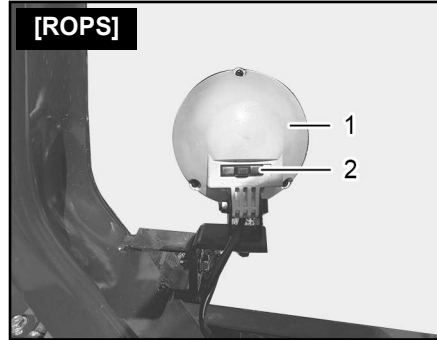
**WORK LAMP (ROPS)**

(1) Work Lamp

(2) Work Lamp switch

It is used for work at rear side at night. The work lamp has an on-off switch itself.

# MEMO

A series of horizontal dotted lines for writing.

# 5. OPERATION

## DAILY INSPECTION BEFORE STARTING .....5-3

## PRE-OPERATION CHECK.....5-3

PRE-OPERATION ..... 5-3

RUNNING-IN PERIOD ..... 5-10

## STARTING / STOPPING THE ENGINE.....5-11

STARTING ENGINE ..... 5-12

COLD START ..... 5-15

STOPPING ENGINE..... 5-15

## TRACTOR OPERATION.....5-16

WHEN ATTACHING WEIGHT ..... 5-16

REDUCE SPEED ..... 5-16

WHEN TOWING LOAD..... 5-16

HOW TO DRIVE ..... 5-17

DRIVING ON THE ROAD ..... 5-21

DRIVING ON THE SLOPE ..... 5-21

ENTERING AND LEAVING THE PAVEMENT ..... 5-22

TURNING ON THE PAVEMENT ..... 5-23

STOPPING ..... 5-23

PARKING ..... 5-24

DIFFERENTIAL LOCK ..... 5-25

TO RAISE OR LOWER THE IMPLEMENT ..... 5-26

ADJUSTING THE LOWERING SPEED

OF THE IMPLEMENT ..... 5-26

TRACTOR LOADING / UNLOADING ..... 5-27

DPF REGENERATION ..... 5-28

## ATTACHMENT OF IMPLEMENT .....5-31

ATTACHMENT POSITION ..... 5-31

TOP LINK ADJUSTMENT ..... 5-32

ATTACHING IMPLEMENT ..... 5-32

ADJUSTMENT OF CHECK BAR ..... 5-33

ADJUSTMENT OF VERTICAL HEIGHT ..... 5-34

ADJUSTMENT OF LIFT LINKS ..... 5-34

INSTALLATION OF PTO DRIVEN IMPLEMENT ..... 5-35

SCV CONTROL LEVER / COUPLER ..... 5-36

CYLINDER HOSE CONNECTION ..... 5-36

PRECAUTIONS FOR

CONNECTING THE IMPLEMENT..... 5-37

PRECAUTIONS FOR HANDLING IMPLEMENT..... 5-38

# 5. OPERATION

<b>ADJUSTING WHEEL TREAD .....</b>	<b>5-42</b>
TIRES, WHEELS AND BALLAST .....	5-43
TIRE TYPE .....	5-43
WHEEL AND AXLE .....	5-43
<b>POWER STEERING .....</b>	<b>5-43</b>
<b>TOWING INSTRUCTIONS.....</b>	<b>5-44</b>
<b>PTO SPECIFICATIONS &amp; PRECAUTIONS .....</b>	<b>5-44</b>
<b>LOADER OPERATION .....</b>	<b>5-45</b>
<b>CARRYING THE LOAD .....</b>	<b>5-46</b>
<b>HANDLING LARGE HEAVY OBJECTS.....</b>	<b>5-47</b>
<b>ROPS FOLDING METHOD .....</b>	<b>5-48</b>
HOW TO FOLD DOWN THE ROPS .....	5-48
HOW TO STAND UP THE ROPS .....	5-48

## DAILY INSPECTION BEFORE STARTING

### 1. Check the engine oil level.

After wiping out the dipstick, insert it fully and then withdraw it. Oil should be between the two marks on dipstick.

Do not operate the engine if oil level is below minimum mark. If below, add the corresponding grade oil according to the season through the filler.

### 2. Feed grease to all greasing points indicated below every 10 hours when working in damp and muddy conditions.

- Front axle pin
- Steering shaft and Cylinder end
- Tie rod both ends
- Front axle supporter

### 3. After cleaning the machine with highly pressurized water, lubricate the indicated points with grease below if necessary.

- Bonnet latch
- Seat sliding rail

## PRE-OPERATION CHECK PRE-OPERATION

### DANGER

- Do not provide illumination with a lit cigarette or a lighter when fueling.
- Never fill the fuel tank while the engine is running or hot.
- After filling the fuel tank, close the fuel filler cap completely and wipe off the excess fuel thoroughly.
- If the fuel hoses are damaged, fuel will leak. Make sure that you check for any leakage.

### WARNING

- Perform the maintenance on a flat and safe location that will keep the tractor in place and will not cause a risk to people passing by. Before carrying out the maintenance, place blocks at the front tires to prevent movement.

[Otherwise]

An unexpected accident may occur, such as overturning of the tractor.

- When going under the implement, fully close the slow/stop valve.

[Otherwise]

There is a risk of injury due to implement falling.

**⚠ CAUTION**

- Stop the engine during checking, maintenance, or repair
- Carry out the maintenance work after heated area such as the muffler or the engine have fully cooled down.

[Otherwise]

There is risk of burn.

- After detaching the covers for checking or maintenance, make sure to put them back in their place.

[Otherwise]

There is a risk that you may get entangled in the tractor or get injured.

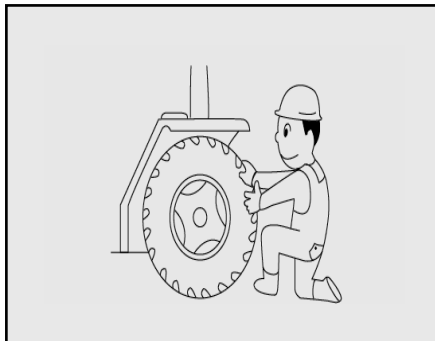

- Deformation, damage or stains.
- Tire pressure and abrasion.
- Damage to the tractor, or loosened bolts.
- Loosening of wheel bolts.
- Fuel quantity, fuel leaks, or damage to the fuel hose.

To ensure a safe and comfortable operation, please carry out the routine check-up everyday before starting work. Correct any problem immediately, and also check for problems after work. This checking should be done in the following sequence.

1. Check the suspicious parts of the previous day.
  - Check the parts that you thought were not normal during the work of previous day.
2. Check around the tractor.



3. Open the engine hood.

- Engine oil level, contamination, or leakage.

- Engine coolant level, leakage, or damage to the hose.

- Battery solution level.



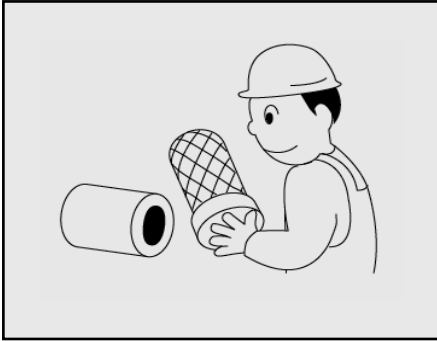

• Air cleaner.

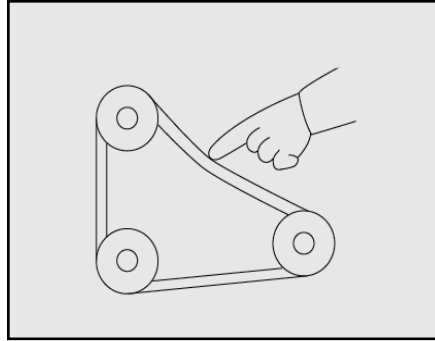

• Fan belt tension, damage.

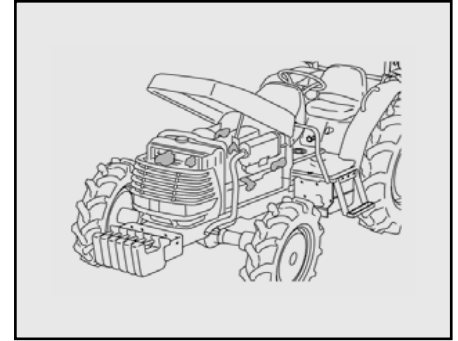

• Dust or straw on the radiator grill or the engine.



- Damage to the coating of the cables, or loosening of the contacts.

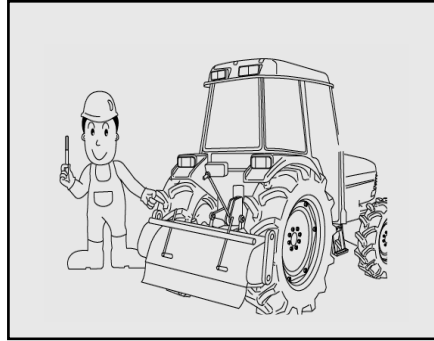

4. Check around the implement.
  - Condition of the locking pin of the universal joint inserted in the PTO shaft.
  - Condition of pins in each part.
  - Loosening of the bolts holding the blade.
  - Quantity of oil in each part. For more details, please refer to the implement manufacturer's instructions.

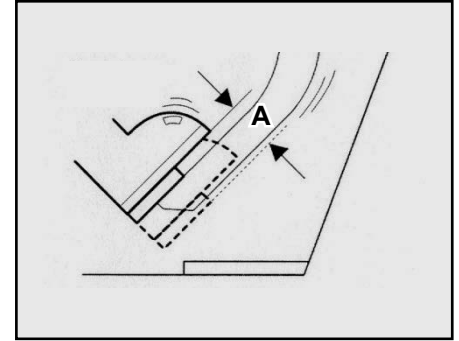

(A) Free play 0.2 ~ 0.4 in

5. Check on the driver seat.

- Operational condition and free play of the brake. (0.2~0.4 in)

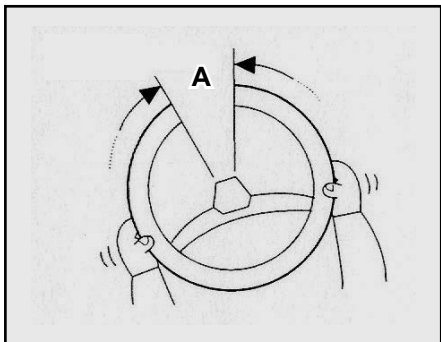

(A) Free play 0.8 ~ 2.0 in.

- Free play of the steering wheel. (0.8~2.0 in.)

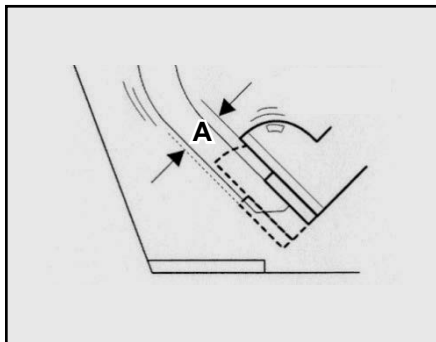

(A) Free play 1.0 ~ 1.4 in.

- Operational condition and free play of the clutch pedal. (Mec. transmission only)

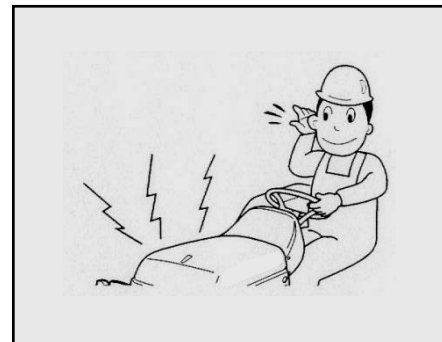

6. Start the engine.
  - Abnormal noise from the engine.

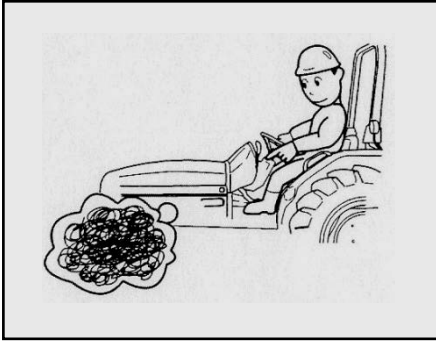

- Color of the exhaust gas.

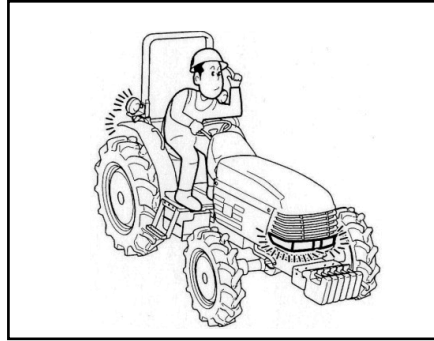

- Operation of lamps and gauges



### Boarding and Leaving The Tractor

Use Steps and Hand-holds Correctly

1. Prevent falls by facing the machine when getting on and off. Maintain 3-point contact with steps and handrails. Never use machine controls as hand-holds.
2. Use extra care when mud, snow, or moisture present slippery conditions. Keep steps clean and free of grease or oil. Never jump when exiting machine. Never mount or dismount a moving machine

## RUNNING-IN PERIOD



### DANGER

- Getting off the tractor, make the implement descend.

[Otherwise]

The implement descends itself, and then causes some unexpected accident.



### IMPORTANT

- Always keep wheel bolts tightened to prevent any accident. Confirm that the wheel bolts are tight before operation. Check wheel bolt torque at least twice within the first 10 hours of operation, check it periodically at every 50 hours thereafter. Change the oil and filter after first 50 hours of operation.

### ► WITHIN FIRST 10 HOURS OF OPERATION

- Inspect daily or every 10 hours
- Tighten the wheel bolts

### ► AFTER FIRST 50 HOURS OF OPERATION

- Tighten the wheel, disc and hub bolts
- Check the alternator and fan belt tension as well as air inlet
- Tighten the cooling system's hose and clamp
- Perform the scheduled 50-hour maintenance
- Change the transmission/hydraulic oil and oil filter element
- Change the engine oil and filter
- Change the front axle fluid

## STARTING / STOPPING THE ENGINE

### DANGER

- When starting the engine, make sure that you are seated in the driver's seat and check position of the levers and the safety around the tractor.

[Otherwise]

There is a risk of injury.

- Do not start the engine in an enclosed space. You must start the engine outside of building. If you should have to start the engine inside a building, make sure that the space is well ventilated.

[Otherwise]

The exhaust gas can cause intoxication and can lead to fatal consequences.

### CAUTION

- Make sure to carry out checking and maintenance before and after the use of the tractor, particularly the operating devices such as the clutch and the brake lever.

[Otherwise]

There is a risk of injury or machinery breakdown. Engage the parking brake during warming-up. Otherwise, the tractor may move and cause an accident.

- Don't crank engine unless hitch control lever is in the lowest position.

[Otherwise]

Implement might rise quickly and there is a risk of injury or machinery breakdown.

Check the engine operation carefully.

### IMPORTANT

- The engine is tuned or set for normal use. In case of a new tractor, especially carry out inspection and check within first 100 hours.
- Be sure to warm up the engine. Inspect the battery charge warning lamp, oil pressure warning lamp and engine coolant temperature gauge.
- Avoid any unnecessary engine idling.
- Frequently check the engine oil, coolant, transmission fluid and front axle oil levels. Also, inspect for leakage of those fluids.

### NOTE

- Make sure to add the corresponding grade oil for the season. Use only genuine oil specified by BAD BOY.

## STARTING ENGINE

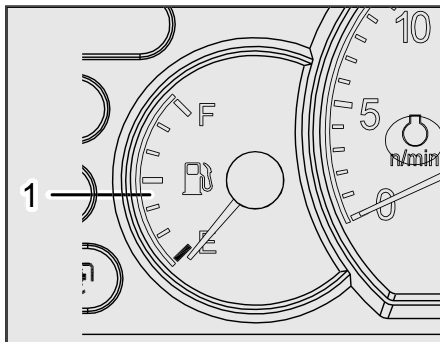

(1) Fuel Gauge

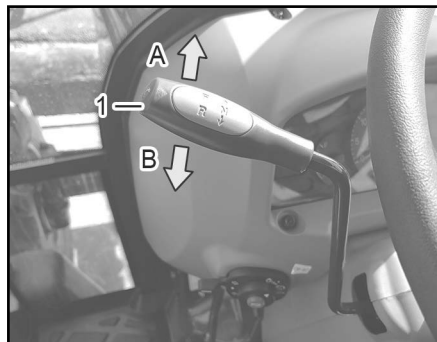

(1) F-R Shuttle Lever  
(A) Forward (B) Reverse

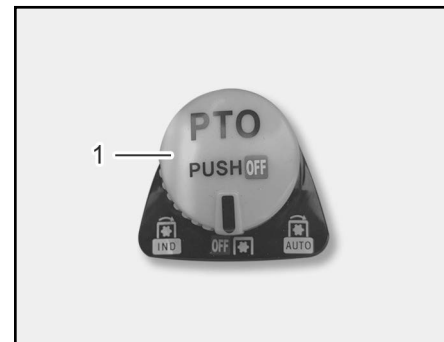

(1) PTO Operation Switch

1. Check the fuel gauge. Make sure that a sufficient amount of fuel is in the tank.

2. Set the shuttle lever in the neutral position. If not, the engine won't be started.

3. Confirm that the PTO operation switch is set in the "OFF" position. If not, the engine won't be started. Turn the PTO switch to OFF.

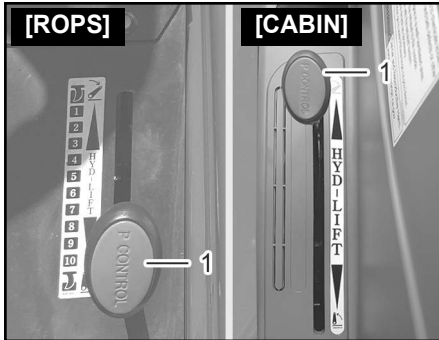

(1) Position Control Lever

4. This position control lever can be used to lower and lift an implement freely.
5. Pulling the lever back lifts the implement while pushing it forward lowers the implement.

### WARNING

- Don't crank engine unless position control lever is in the lowest position.

#### [Otherwise]

Implement might rise quickly and there is a risk of injury or machinery breakdown.

- Check the safety around the tractor and start to move slowly.

#### [Otherwise]

There is a risk of injury.

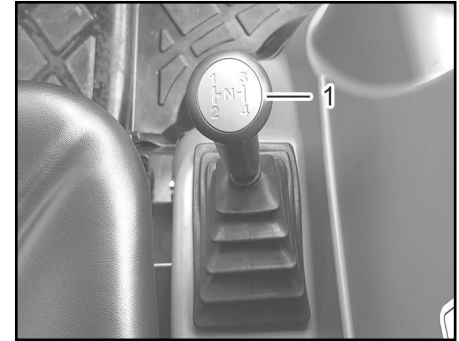

(1) Main shift lever

6. Put the main shift lever in the neutral position.



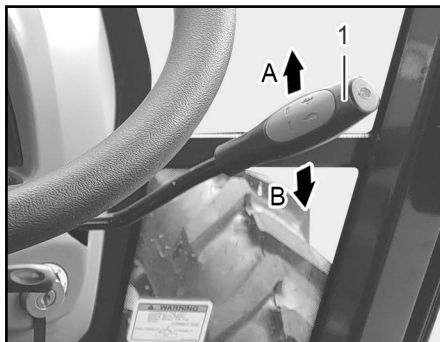

(1) Accelerator Lever

 : Slower Engine RPM (A)

 : Faster Engine RPM (B)

7. Place the accelerator lever to the Minimum position.
8. After the thermostat lamp has turned off, depress the clutch pedal fully and turn main key switch to start.

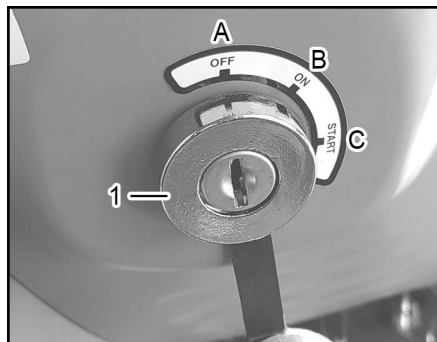

(1) Main (Ignition) Key Switch

(A) OFF

(B) ON

(C) START

9. Turn the main (ignition) key switch to the "START" position. When the engine is started, take your hand off the key.
10. Increase the engine to about 1,500 rpm and warm it up for about five minutes without a load.

### IMPORTANT

- Do not operate the start motor more than 20 seconds at a time. If the start motor won't start, wait until the motor is cooled down at least for 2 minutes and then try again.

## COLD START

### CAUTION

- In case of the tractor equipped with the cold start system, do not use starting fluid.

1. When starting in cold weather, turn the main (ignition) key switch to the “ON” position and then wait until the preheat lamp is turned off.
2. For safe operation, turn the main (ignition) key switch to the “START” position with the clutch pedal depressed.
3. Repeat the above procedures until the engine is operated smoothly.
4. Let the engine idle at 1,200 rpm to warm up the engine up to the operating temperature.

## STOPPING ENGINE

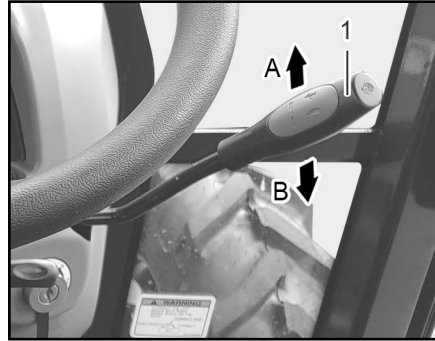

(1) Accelerator Lever

 : Slower Engine RPM (A)

 : Faster Engine RPM (B)

1. Put the acceleration lever on LOW, and turn the main (ignition) key switch to “OFF”.
2. Put shuttle lever, main gear shift lever and PTO shift lever to “N”. Put PTO ON/OFF switch in to the “OFF” position and 4WD lever position on disengage.
3. Put the hitch control lever on “DOWN”

### CAUTION

- When stopping the engine, never stop it with the reducer lever.
- After stopping the engine, make sure to apply the parking brake.

### NOTE

- For warming-up operation, strongly step on the brake pedal and pull your parking brake.

### WARNING

- When leaving the tractor, park the tractor in a flat and safe place, put the shuttle lever and the main shift lever to “N”, and block the tires.

[Otherwise]

The tractor may move and cause an accident. Always set the parking brake.

## TRACTOR OPERATION WHEN ATTACHING WEIGHT



 **CAUTION**

- Do not drive on a road under a heavily loaded condition. Otherwise, it can lead to an injury or machine damage.

1. Reduce the speed when driving on a bumpy or rough ground.
2. Attach the additional weight needed for stability and safe cornering if required.
3. Make sure that the front wheels are not risen up when transporting implements or towing a heavy load.

## REDUCE SPEED WHEN TOWING LOAD

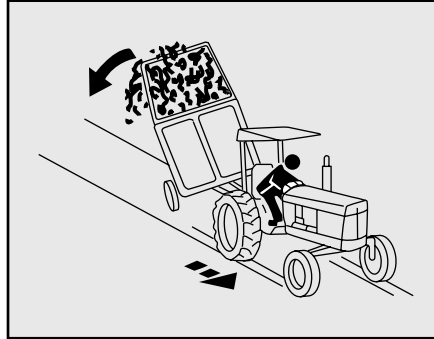

 **CAUTION**

- The stopping distance becomes longer on a downhill in proportion to the speed and load weight. If the towed weight is heavier than the tractor and the braking system is not installed on the trailer, reduce the speed. Observe the guideline for towing speed and capacity.

Observe the guideline for towing speed and capacity as below.

1. If the trailed weight is the same or lighter than the tractor, maintain the maximum speed of 26 km/h.
2. If the trailed weight is twice the tractor or less, maintain the maximum speed of 13 km/h.
3. If the trailed weight is more than twice the tractor, do not tow it.
4. Be careful especially when towing a load on a bad condition of ground, slope or corner.

## HOW TO DRIVE



(1) Seat belt

(2) Seat sliding lever

1. Adjust the seat properly and fasten the seat belt. Adjust the seat to easily reach the pedal and the steering wheel.

If the seat belt is worn across the abdomen or waist, not the hips, an injury can occur in case of an accident or impact.

Adjust the levers properly according to the driver's physical condition.



### CAUTION

If the tractor is out of control, it can cause a personal injury or even death. Keep the following instructions on a road:

- Interlock the both brake pedals.
- Use the foot throttle pedal.
- Reduce the speed while driving on a slippery, or gravel road.
- Attach the proper weight.
- When reducing the speed, use the brake gently and carefully.



### IMPORTANT

- Don't put a foot on the brake pedal unnecessarily during driving. Such action can reduce the brake's service life.

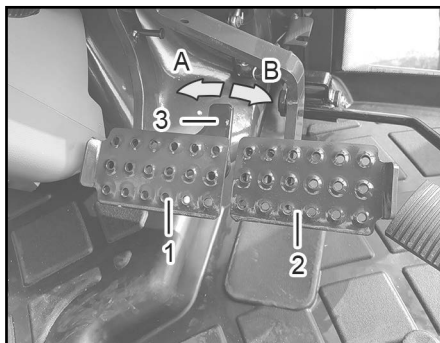

- (1) Left Brake Pedal
- (2) Right Brake Pedal
- (3) Link Bracket
- (A) Release
- (B) Engage

2. Check if both brake pedals are interlocked.

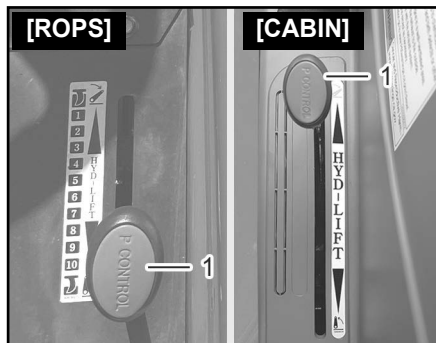

- (1) Position Control Lever

- 3. This position control lever can be used to lower and lift an implement freely.
- 4. Pulling the lever back lifts the implement while pushing it forward lowers the implement.

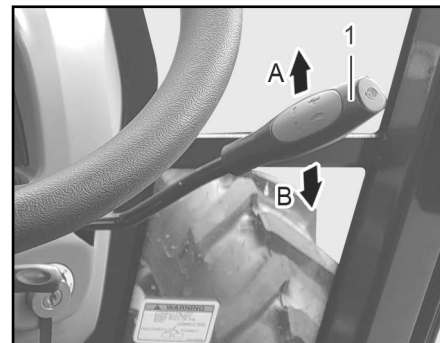

- (1) Accelerator Lever
- : Slower Engine RPM (A)
- : Faster Engine RPM (B)

5. Control the accelerator lever. Increase the engine rpm from low to high speed gradually.

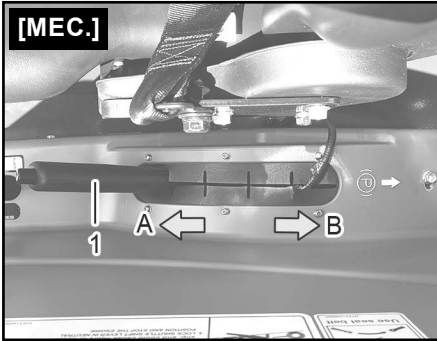

6. Release the parking brake.

► **MEC.**

Press the button on the end of the parking brake lever and push the lever forward.

► **HST**

Put the lever down.

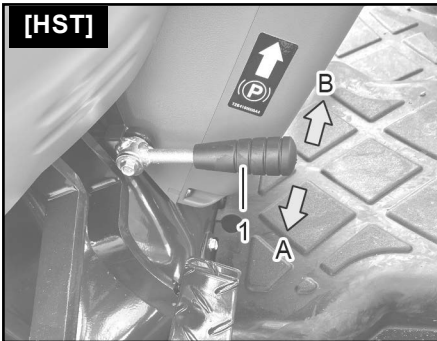

(1) Parking Brake Lever  
(A) Release (B) Lock

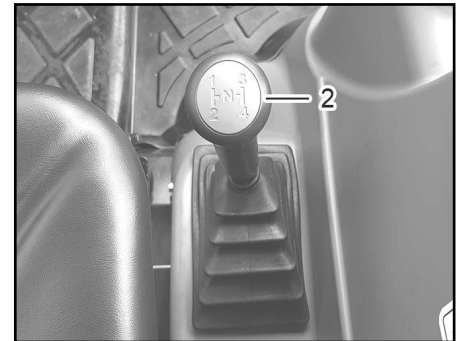
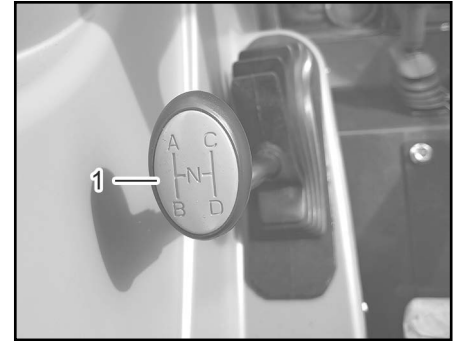

(1) Range shift lever (2) Main shift lever

7. Put the main and range shift levers into the proper positions as the operator's intention.



**CAUTION**

- The range shift lever should be operated while the vehicle is stationary. If not, there is a risk of machinery damage.

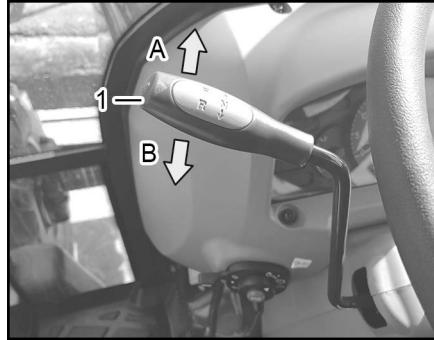

(1) F-R Shuttle Lever  
(A) Forward (B) Reverse

8. Operate the shuttle lever. This lever is used to select forward or reverse driving of the tractor. Shift the lever with the clutch pedal and brake pedal depressed to maximum.



**CAUTION**

- Don't put a foot on the clutch pedal unnecessarily during driving. Otherwise, the clutch is set in the slip position, resulting in premature wear of the clutch.
- Do not change the tractor speed abruptly for safe driving.
- Be careful of all directions of the tractor before driving. If not, it can cause an accident.
- When driving on a steep slope or moving to a location for loading or unloading, do not put your hand on the main shift lever. If the shift lever is half engaged, it can lead to an accident. Make sure to place the lever in the low speed position in advance.

## DRIVING ON THE ROAD

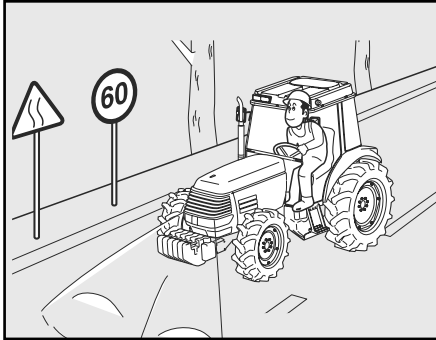

### ⚠ WARNING

- When driving on a road or crossing a dike, make sure to connect the brake pedals. Otherwise, the tractor may turn abruptly or turn over due to one-sided braking.
- Observe the traffic regulations when driving on the road. Otherwise, you may be involved in an accident.

### ⚠ WARNING

- This tractor is designed to accommodate only one person. Do not allow anyone on the tractor other than the driver. Otherwise, you will be exposed to a risk of accident.
- Put the PTO lever into “N” and connect the brake pedals.
- When making a turn, turn on the direction indicator lamp to inform other vehicles of your intention.
- Pay particular cautions to narrow farm roads, slopes, and grassy shoulders, and reduce the speed.
- Put the position control lever to UP and lock it with the stopper. Otherwise, you will be exposed to a risk of an accident.
- Connect the brake pedals when driving on a road. Otherwise, there is a risk of abrupt turning or overturning due to one-sided braking.
- Before every operation, make sure that operator wears safety belt.

## DRIVING ON THE SLOPE

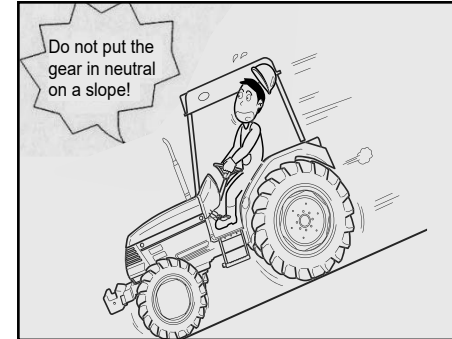

### ⚠ WARNING

- Select a proper speed, and do not shift the gear.
- Do not park on a slope. Otherwise, the tractor may slip or overturn and cause an accident.
- Reduce speed and pay special attention to the speed.



## ENTERING AND LEAVING THE PAVEMENT

### WARNING

- Do not depress the clutch pedal when driving on a slope. The tractor may slide down and lead to a serious situation.
- When starting the tractor upwards on a slope, start slowly in low gear with low engine rpm. Otherwise, the front of the tractor may be lifted and cause a very dangerous situation.
- You may shift the gear when you are no longer on the slope. If you stop on a slope, apply the parking brake. Otherwise, you may be exposed to a risk of accident.

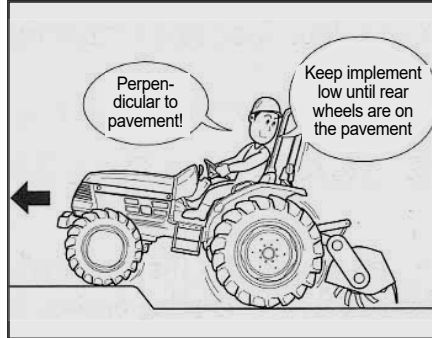

### WARNING

- Make sure to connect the brake pedal. Otherwise, the tractor may turnover due to one-sided braking.

### WARNING

- When you cross a dike or raised ground to enter or leave the pavement, use loading ramps with sufficient strength, and lower the implement to achieve a lower center of gravity.
- Drive backward when climbing up a steep slope, and drive forward when climbing down.

### NOTE

- Enter or leave the pavement in a perpendicular direction. When climbing onto the pavement, lower the implement to achieve a lower center of gravity. Once all wheels of the tractor are on the pavement, raise the implement.

## TURNING ON THE PAVEMENT

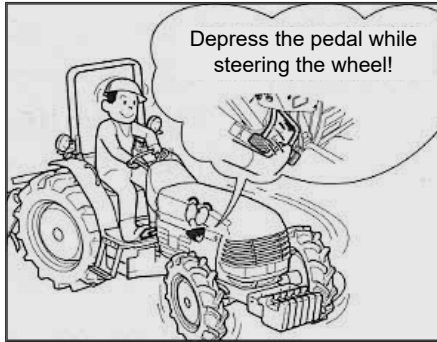

When making a turn, reduce the engine rpm and make a slow turn. When making a turn on the pavement, remove the connector of the brake pedals. Depress the brake pedal on the side to which to make a turn, while steering the wheel, this will allow the tractor to make the turn without moving ahead. Make sure to keep the implement in the up position when making a turn.

### WARNING

- **Make sure to release the differential lock before making a turn.**

[Otherwise]

**The tractor will not turn in the intended direction. It may cause an accident.**

## STOPPING

1. Stop the tractor with the brake pedal.
2. Put the main shift lever to the neutral position.
3. Put the shuttle lever to the neutral position.
4. Put all SCV levers to the neutral position.
5. Set the PTO switch in the "OFF" position.
6. Lower all implements on the ground.
7. Push the accelerator lever back slowly to decelerate the engine and keep the engine for 1~2 minutes of unloaded idling.
8. Make sure the parking brake is applied.
9. Turn the main (ignition) key switch to the "OFF" position to stop the engine.

### CAUTION

- **When leaving the tractor, put the shuttle lever into the neutral position. If not, the tractor may move even though the engine is stopped.**

## PARKING

### ⊕ IMPORTANT

- The tractor needs to be stationary before making a shift. If the parking brake is applied while the tractor is moving, the transmission can be damaged.
- Each part of the engine is cooled down by the engine oil. If the hot engine is suddenly stopped, its high temperature or insufficient lubricant can cause damage to the related parts.

### ⚠ CAUTION

- Remove the main (ignition) key before leaving the tractor to prevent its use by an unqualified person.

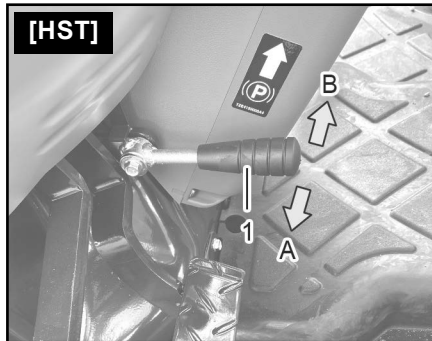
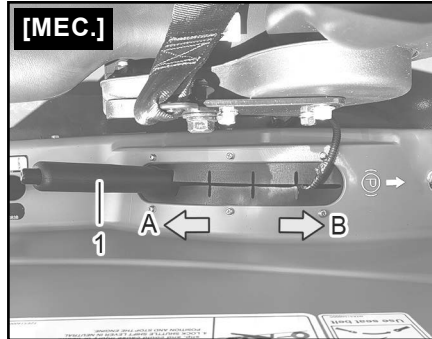

(1) Parking Brake Lever  
 (A) Release (B) Lock

1. When parking or stopping the tractor, pull the parking brake lever securely.

### ⚠ CAUTION

- The brake disc can be rapidly worn if you drive with the parking brake applied. To park the vehicle, apply the parking brake and then place prop under the rear wheels.

## DIFFERENTIAL LOCK

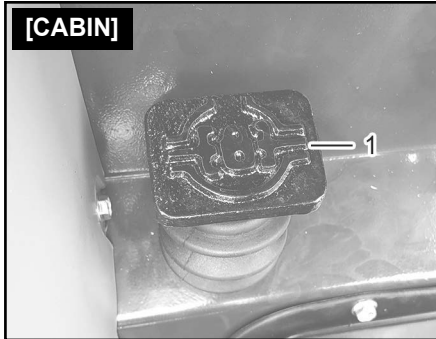

(1) Differential Lock Pedal

1. When the speed at one wheel starts to drop, depress the differential lock pedal to activate the differential lock.
2. If the wheel traction resistance on both wheels are not even, the differential lock keeps being engaged. While both wheel traction resistance is even, the differential lock is automatically disengaged. If the differential lock is not disengaged, depress one and another brake pedal separately.
3. If the tire is rotating idle repeatedly, try to engage the differential lock again.



### CAUTION

- Do not drive the tractor at high speed or make a turn with the differential lock engaged.



### IMPORTANT

- To prevent the power train from damage, do not press the differential lock pedal when one wheel is spinning fast and the other wheel is stopped.

## TO RAISE OR LOWER THE IMPLEMENT

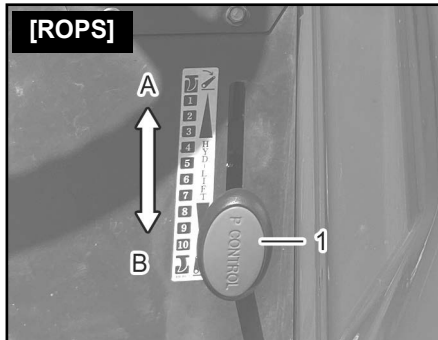
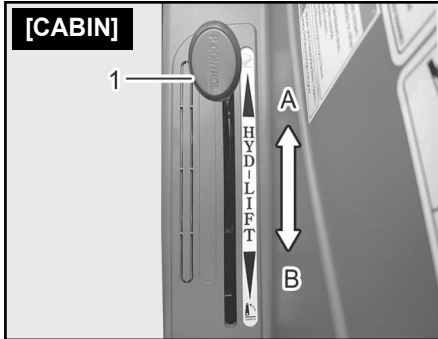

(1) Position Control Lever  
(A) Down (B) Up

1. This position control lever can be used to lower and lift an implement freely.
2. Pulling the lever back lifts the implement while pushing it forward lowers the implement.

### CAUTION

- To avoid a personal injury, use the position control lever when attaching/detaching the implement.

## ADJUSTING THE LOWERING SPEED OF THE IMPLEMENT

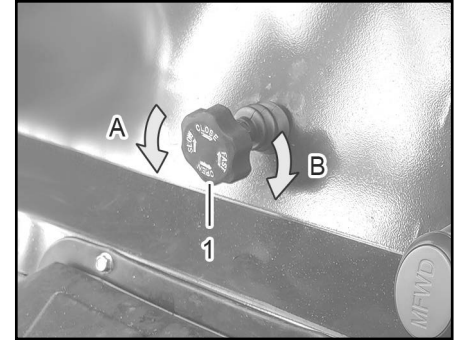

(1) Flow Control Valve  
(A) Fast (B) Slow

For adjusting the lowering speed, turn valve (A) to the left for faster movement or (B) to the right for slower movement. Turning the valve fully to the right (B) will block the hydraulic pressure and will cause the implement to stop.

**TRACTOR LOADING / UNLOADING** **WARNING**

- Do not work under or put a foot under the implement.

[Otherwise]

The implement may fall and cause an injury.

 **DANGER**

- Fix the direction so that the tractor will not have to modify its direction on the loading bridge, and proceed at the lowest speed.
- Never depress the clutch pedal to change direction or stop.

[Otherwise]

There is a danger that the tractor may turn over.

 **WARNING**

- Loading and unloading must be done on a flat and safe place, with the engine turned off and the parking brake engaged. The loading lamp must be non-slippery and have sufficient strength, length, and width for the tractor. To avoid slipping of the loading lamp, latch it securely onto the truck. Move the tractor backward when loading, and forward when unloading. Fasten the tractor to the truck securely with rope.

[Otherwise]

The tractor may fall off the truck and cause an accident.

## DPF REGENERATION



(1) DPF Regeneration Switch

### 1. Engine Max Rpm

Keep above max rpm with Accelerator lever. However, the following conditions must be satisfied.

- Parking on
- Gear Neutral
- Shuttle Neutral (Mechanical)  
& Pedal Neutral (HST)
- Cooling water temp. 60 ~ 100°C

### 2. To press the regeneration button for more than 3 seconds.

Press and hold for more than 3 seconds to display the related regeneration lamp on the instrument Panel.







Blinking



### 3. DPF regeneration completed after 30 minutes.





When the DPF regeneration is completed, the regeneration lamp is turned off on the instrument panel.

## DPF REGENERATION INDICATION

Items	Lamp Indication		Description
DPF regeneration time reached		Light on	If the DPF has more than a certain amount of soot, it informs the driver that it is time to regenerate. [Buzzer] Buzzer sounds 3 times every minute.
DPF regeneration starts			If driver press the regeneration button for more than 3 seconds in high idle, driver can enter the regeneration mode. [Buzzer] Buzzer sounds for 2 seconds at start
DPF regeneration proceeding		Light on	Controlling the exhaust valve to burn soot on the DPF. [Buzzer] Buzzer sounds once every 3 minutes
		Blinking per 0.5 sec.	
DPF regeneration complete		Lamp off	Regeneration is completed after 30 minutes from the start of regeneration. [Buzzer] Buzzer sounds 3 times after 3 minutes of DPF regeneration.

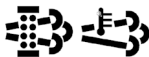
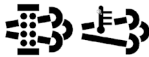

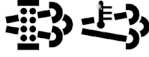
## ERROR DISPLAY DURING DPF REGENERATION

Items	Lamp Indication	Description
Engine overheating		Blinking Activates when the cooling water temperature exceeds 105 degrees during DPF regeneration. You can not retry regeneration within 10 minutes. [Buzzer] Repeat 1 sec. Sound On → 0.5 sec. Sound Off, and if it goes below 100 degrees, Buzzer is turned off.
Regeneration fail		Blinking By judging after the end of the regeneration period, it activates when the differential pressure does not decrease by more than 100 mbar compared with the start of regeneration even though the differential pressure is blocked at the start of regeneration.
3 times consecutive regeneration failures		Blinking Even if the DPF regeneration has been completed after 3 consecutive regeneration tries, check the pressure difference due to soot.
Regeneration off		Blinking If regeneration stop during regeneration operation for any of the following reasons. - Engine less than 2,600 rpm - Post DPF(EGTS2) temperature overheat - Not parking
Engine stop during regeneration		Blinking for 10 min Blinking for 10 minutes if engine stop is detected during regeneration and the differential pressure is greater than 130 mbar at restart.
DPF error		Light on Activates when the DPF is damaged or removed.

## ATTACHMENT OF IMPLEMENT ATTACHMENT POSITION

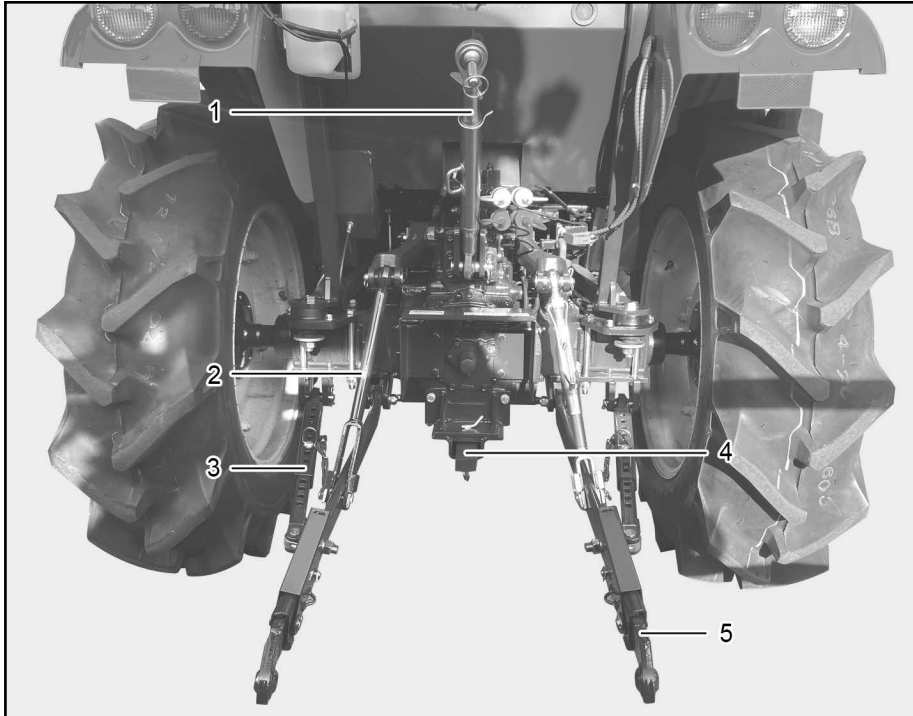

(1) Top Link  
(2) Lift Rod

(3) Check Link  
(4) Draw bar

(5) Lower link

### CAUTION

Select an implement to match the tractor horse power;

The tractor horse power should correspond with the size of an implement. If the power level of tractor is exceeded, the implement may be damaged. Also, if the implement is too big, the tractor may be damaged. Be sure of the maximum and minimum power of the tractor before attaching an implement.

## TOP LINK ADJUSTMENT

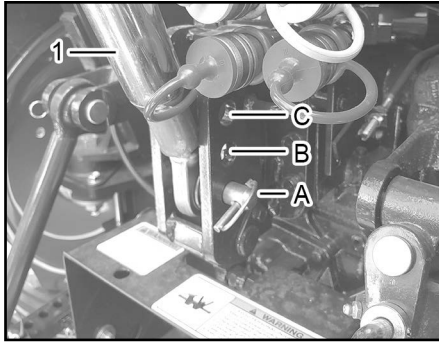

- (1) Top Link            (A) High traction  
 (B) Mid traction      (C) Low traction

The top link can be installed to 3 selective positions according to the working condition.

A: If the top link is attached to the bottom position, the draft system will be activated with highest sensitivity which is suitable for the implement such as a plow or equivalent which requires traction force.

B: The center hole is the standard installation hole for a rotary tiller.

C: If the top link is attached to the top position, the draft system will not be activated. This is good for the implement such as a drilling machine or equivalent which does not require any traction force.

## ATTACHING IMPLEMENT

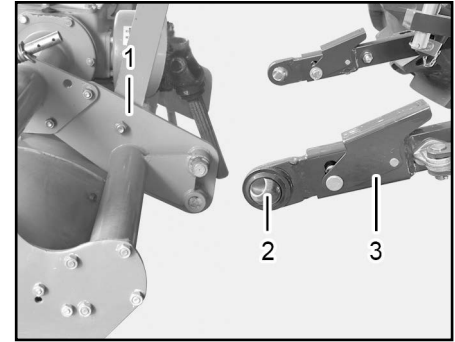

- (1) Implement            (2) Ball  
 (3) Lower link

1. Drive the tractor backward to move close to an implement to fit the position of 3-point hitch.
2. Apply the parking brake and stop the engine.
3. Open the lock button on the lower link and position the implement; then, close and fasten the lock button.

**⚠ WARNING**

- To prevent the locker shaft from unexpected movement, turn “OFF” the traction (draft) control before attaching the implement to the hitch.

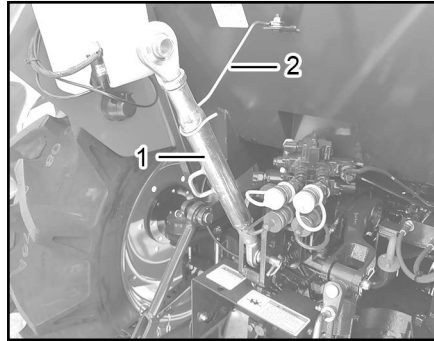

(1) Top link

(2) Fixing bracket

4. Detach the top link from the fixing bracket.
5. Attach the top link to the top mast of the implement.
6. Adjust the length of the top link and lower link if required.

**⊕ IMPORTANT**

- Do not extend the top link excessively out of the limit. The top link's body or thread can be damaged.

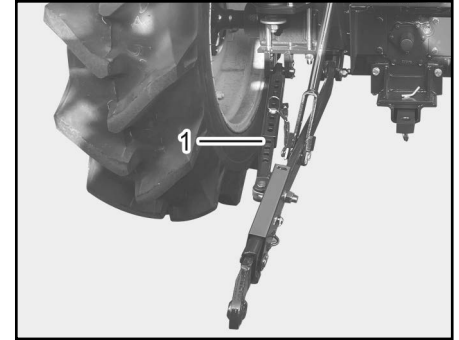
**ADJUSTMENT OF CHECK LINK**

(1) Check Link

1. For implements such as a plow and disc harrow, adjust the length so that it can be moved for 5 ~ 6 cm sideways.
2. For implements such as a rotary tiller and mower, adjust the length so that it cannot be swayed sideways.

## ADJUSTMENT OF VERTICAL HEIGHT

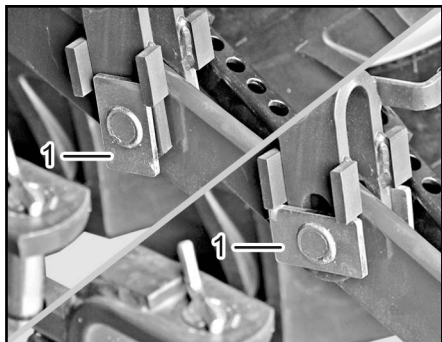

(1) Rectangular steel plate

1. To let the implement float along contour of the ground, turn the rectangular steel plate to the vertical position.
2. To secure the implement, turn the rectangular steel plate to the horizontal position.



### CAUTION

- Always check if there's no interference with the implement, quick-coupler of the implement, and other attachments when attaching to the 3-point hitch to avoid fatal personal injury or machinery damage.

## ADJUSTMENT OF LIFT LINKS

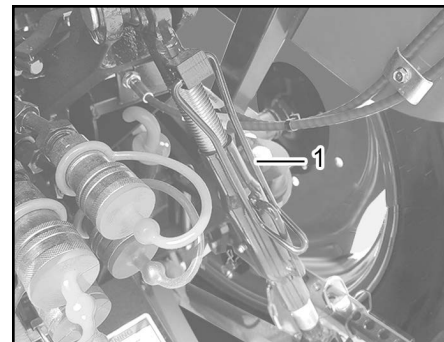

(1) Lift Link Lever

Turn the A-lever clockwise to rise up lift links. On the contrary, turn the A-lever counter clockwise to lower down lift links.

## INSTALLATION OF PTO DRIVEN IMPLEMENT

1. Attach the implement to the tractor.
2. Lift the implement off the ground.
3. Stop the engine and put the PTO shift lever in the neutral position.
4. After opening the PTO cover, connect the universal joint shaft while turning the PTO shaft by hand so as to align the splines.
5. To check the PTO shaft is secured, check if the pin is returned to the original position by pulling the universal joint shaft.
6. Close the PTO cover.
7. Adjust the PTO shift lever according to the working speed.
8. Check if the safety shields are in place and working environment is normal. If the master safety shield is not installed, do not operate the PTO. Stop the engine to check the PTO shaft and its guards Repair or lubricate if required.
9. The PTO shaft should not be interfered by any surrounding parts.



### CAUTION

- **If someone is entangled in the rotating part, it can cause a fatal injury. Always wear protective gear and install the safety shields and guards to the drive line. Don't wear loose clothing.**
- **Do not remove the installed protective cover of the PTO drive shaft without permission. If working with this protective cover removed, it can cause a severe injury. Refer to the warning decal on the cover.**

## SCV CONTROL LEVER / COUPLER

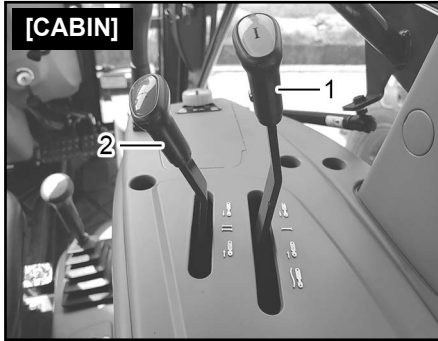

(1) SCV Lever (I)      (2) SCV Lever (II)

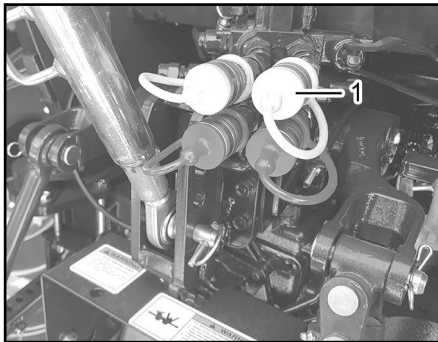

(1) Coupler

The SCV control lever adjusts the flow and volume of oil from the SCV valve at the rear of the tractor. The left coupler is for expansion and the right coupler is for retraction.

## CYLINDER HOSE CONNECTION

1. Make sure to use the correct hoses for expansion and retraction. The expanding hose must be connected to the left coupler. The retracting hose must be connected to the right coupler.
2. Remove the dust cap from the end of the hose.
3. Slide the coupler cap.
4. Make sure the end of the hose and the coupler are clean. Insert the hose tip correctly into the coupler. Pull the hose once to make sure the hose is correctly inserted into the coupler.
5. When connecting an external hydraulic hose, be careful not to let foreign substances enter. Be sure to clean the connector and assemble it in a clean state.

**CAUTION**

- **High pressure oil leaking under pressure can penetrate the skin and cause severe wounds. Avoid danger by reducing pressure before disconnecting hydraulic or other wires. Tighten all connections before applying pressure.**
- **To check for leakage, use a piece of cardboard and protect your hands and feet from the pressurized fluid.**
- **Get medical attention immediately in case of accident. Fluids injected into the skin may rot if not removed surgically within a few hours.**
- **External hydraulic hoses can be damaged by physical damage, aging and explosion. Check the hoses regularly. If the hose is damaged, replace it immediately.**

**PRECAUTIONS FOR CONNECTING THE IMPLEMENT**

1. When engaging or disengaging the implement by moving the tractor, make sure that no one is allowed around the tractor or between the implement and the tractor.
2. Engage or disengage the implement on a flat and safe place. Supply proper lighting at all times and especially at night.
3. When engaging a heavy implement, load the weight on the front to keep the balance of the tractor.
4. When adjusting the implement, apply the parking brake, switch off the engine, and confirm that the PTO lever is on the "OFF" position.
5. When towing something, make sure to use the draw-bar.
6. Increase the wheel tread on a slope or when towing.
7. Depending on the implement, the overall length may become very long. Pay particular attention to people or objects nearby when making a turn.
8. Do not substitute the balance weight with a person or anything else. Always use the recommended balance weight.
9. For front loader work, mount an implement on the rear to keep the balance of the tractor.
10. Read the instruction Mec. of the implement mounted to the tractor.

**WARNING**

- **When the PTO shaft is not in use, affix the safety cover on it.**

**[Otherwise]**

**There is a risk of getting entangled in the tractor or injured.**



## PRECAUTIONS FOR HANDLING IMPLEMENT

1. When driving the tractor to attach or detach an implement, make sure that there is no one in between or around the tractor and implement.
2. Install and remove the implement only on safe and level ground.
3. When engaging a heavy implement, load the weight on the front to keep the balance of the tractor.
4. When adjusting an implement, apply the parking brake, stop the engine and set the PTO switch in the "OFF" position in advance.
5. To tow anything, use the towing hitch only.



### WARNING

- **Read instructions on warning decals on each implement thoroughly before work.**
- **To avoid an injury due to mishandling of an implement, read the user's manual of the implement thoroughly and work safely and precisely with caution.**
- **Installation of an improper implement can lead to an injury. Install only implements specified by the Manufacturer.**

### ▶ ROTAVATOR

#### <Safety precautions for rotavator>

- Never remove the safety cover of the rotavator.
- Do not remove the PTO shaft cover and safety cover on the universal joint.
- When adjusting each part, disengage the PTO and stop the engine in advance.
- When driving on a road, keep the PTO disengaged. Also, keep the rotavator lowered on a road as long as it does not hit the ground.
- For the universal joint, its inner shaft and outer shaft should be overlapped at least 15 cm.
- Check that the universal joint is firmly fixed to the tractor and rotavator shaft.

## ► EFFECTIVE PLOWING PATTERN

### <Safety precautions for rotavator>

- This pattern can be useful in a well-planned field in a good condition.
- The border shown in the figure is the effective plowing width of the rotavator and should be set a little narrower than three times of one plowing width.
- The starting point is the ending point.
- Plow in a sequential pattern from (1) to (6) and in a circular pattern from (7) to (18).
- When driving forward to plow, have the bank on the right side.
- Be careful not to press already-plowed soil with the wheels.

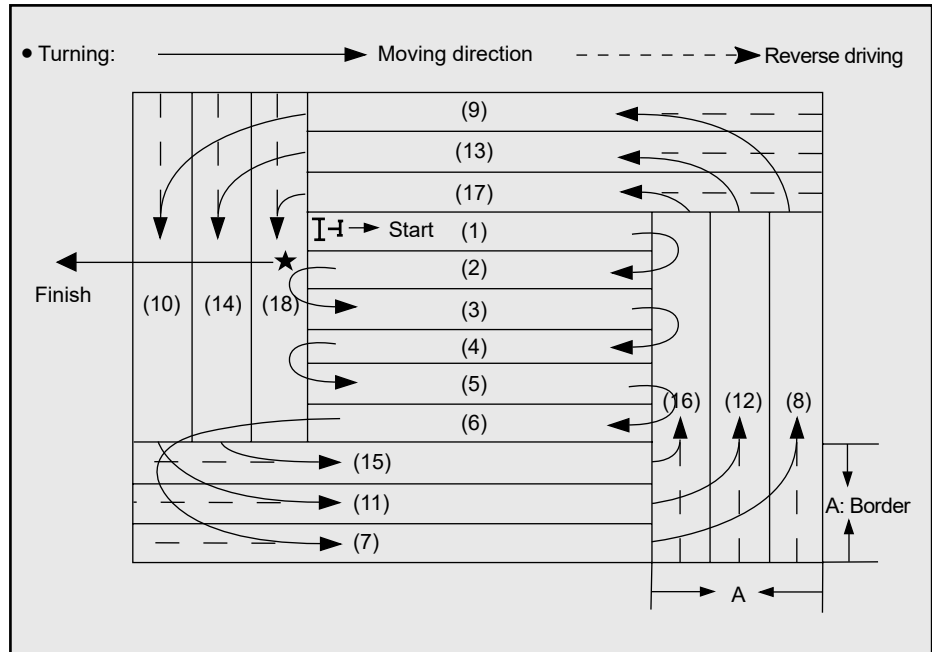

► **ALTERNATING RETURNING PLOWING PATTERN**

- This pattern is useful for narrow or short fields or poorly planned fields in which are not easy to turn.
- In the figure, the plowing width for (1), (2), (3) and (4) should be overlapped with the one for (5), (6) and (7) for approx. 10cm.
- For the sections (1) to (7), perform plowing in an alternating pattern. For the sections (8) to (19), plow in a circular pattern.
- Refer to the sequential returning pattern for other details.

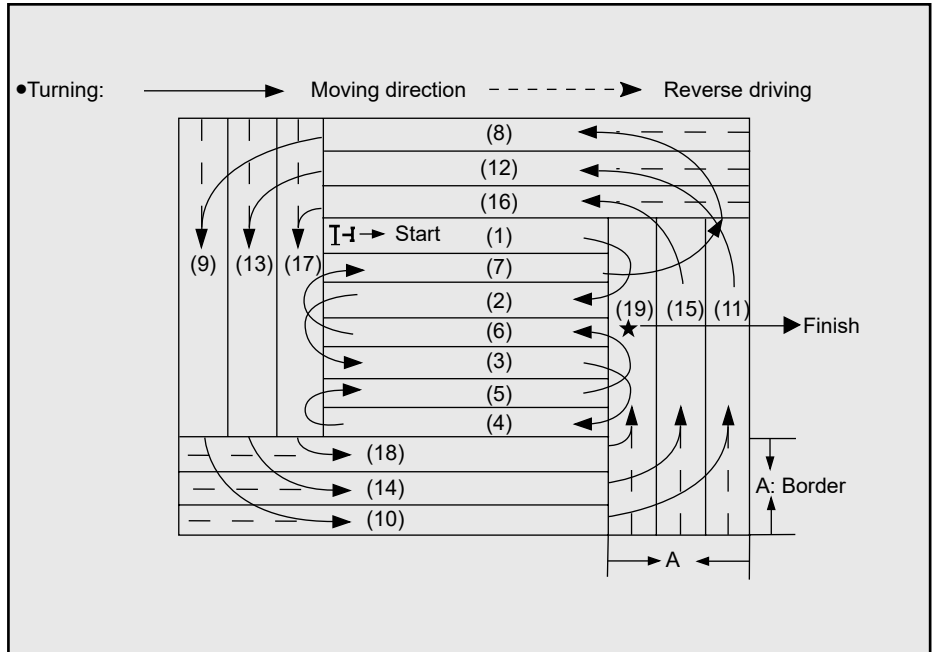

### ► LAND LEVELING PATTERN

- The land leveling work may be performed after crushing soil or not.
- The vehicle speed can be set faster when performing the land leveling work with soil crushed already.
- When working in a wet field, fill the field with a sufficient amount of water so that the trace of plowing cannot be seen.
- The border shown in the figure should be set a little narrower than two times of one plowing width.
- Refer to the alternating returning pattern for other details.

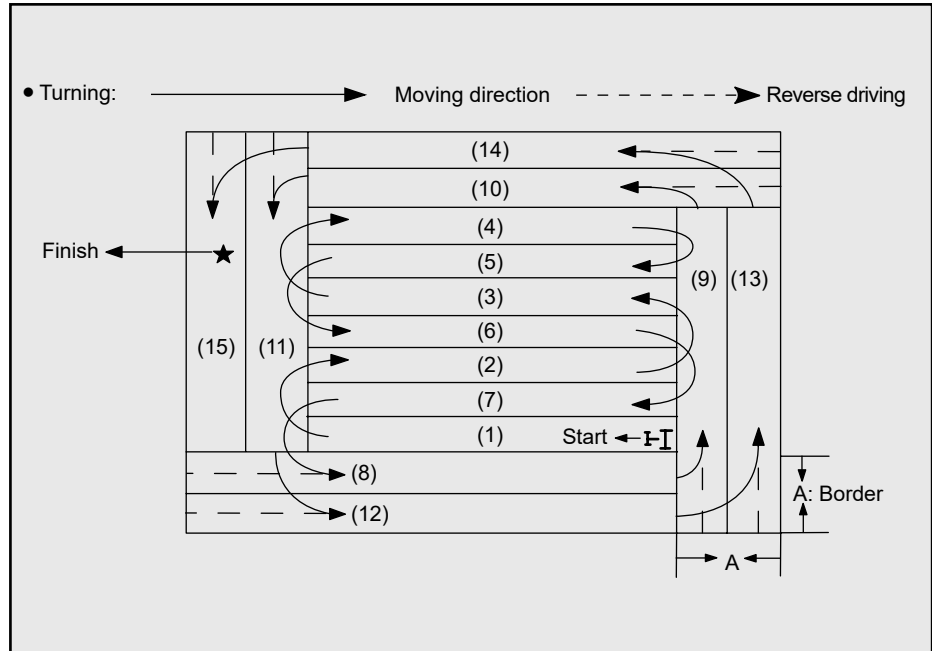

## ADJUSTING WHEEL TREAD

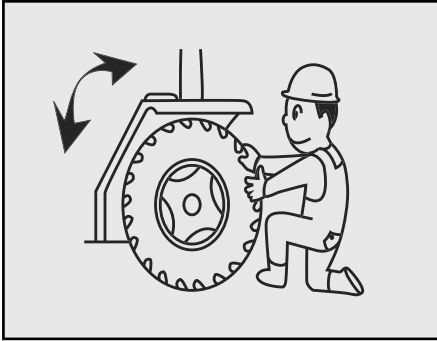

Adjust the wheel tread depending on the type and condition of the work. Also, increase the wheel tread when working on a slope or towing.

1. Pull the parking brake, block the front wheels, and raise the body with a jack to make the rear wheels separate from the ground.
2. Be sure to make adjustments alternatively between the left and right wheels.

### ► TIGHTENING TORQUE

#### **⚠ WARNING**

- When changing tires, please use a hoist or strong support and make sure the tractor does not move.

[Otherwise]

There is a risk of death or injury.

	DESCRIPTION	TIGHTENING TORQUE
<b>FRONT WHEEL</b>	Bolts on wheels and axle	130 ~ 152 lb-ft (18 ~ 21 kgf.m)
<b>REAR WHEEL</b>	Bolts on wheels and axle	130 ~ 152 lb-ft (18 ~ 21 kgf.m)
	Bolts on rim and disk of wheels	188 ~ 224 lb-ft (26 ~ 31 kgf.m)

## TIRES, WHEELS AND BALLAST TIRE TYPE

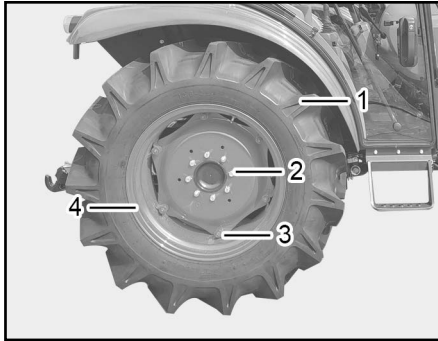

- (1) Tire                      (2) Wheel nut  
(3) Rim bolt                (4) Rim

Though the tire pressure is factory set to the prescribed level, it naturally drops slowly in the course of time. Thus, check it everyday and inflate as necessary.

## WHEEL AND AXLE

If the wheel or axle is loosened, tighten to the specified torque.

1. Drive the tractor about 100m and tighten it to the specified torque.
2. Inspect the wheel and axle every 10 hours of engine run or every 3 hours of working.
3. Inspect all wheels and axles frequently and securely tighten if necessary.



### CAUTION

- **Never operate the tractor with a loose rim, wheel, hub or axle.**

### NOTE

- **When operating a new tractor or when removing the wheel, follow the procedures above.**

## POWER STEERING



### CAUTION

- **Pay attention to the steering wheels while driving, because it can be very lightly manipulated when the engine is running.**
- **Power steering will run only when engine is running. When engine is idling, power steering may feel a little heavy.**
- **If the wheels are steered to the maximum, the relief valve is opened and a warning sound will be made. Do not continue to operate the tractor with the warning sound.**
- **Do not steer the wheels unnecessarily, because steering the wheel without moving will attribute to early wear of tires and rims.**

## TOWING INSTRUCTIONS

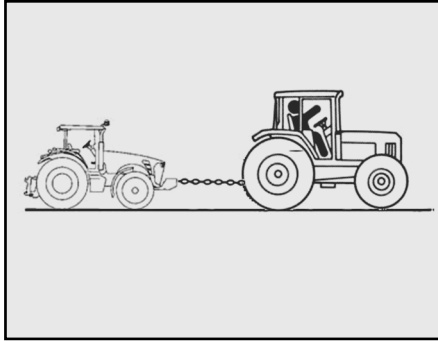

1. Tractor traction should be conducted in short distance. (For instance, from inside to outside)
2. Long distance towing is not allowed in traffic congestion.
3. In case tractor needs to tow, use strong and safe checked chain.
4. Traction must be conducted from the rear in usage of tow bar, tow hook and 3-point linkage.

5. When driver turns the handle, use the brake if necessary.
6. During traction, the transmission and other parts, are not being lubricated but rotating. In order to prevent breakage, please note the following:
7. Towing should be in short distance.
8. Traction speed is restricted to less 8 km/h.
9. If possible, start the engine in order to make the power steering lubricated.
10. Place the main gearshift and sub gearshift in neutral.

## PTO SPECIFICATIONS & PRECAUTIONS

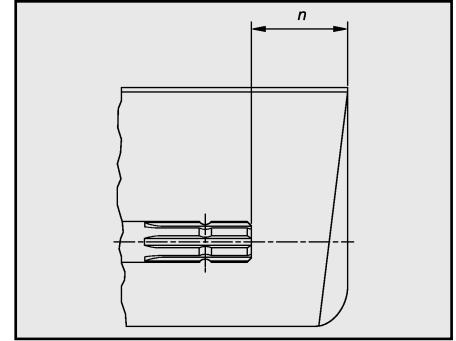

Wear close fitting clothing. Stop the engine and be sure that PTO driveline is stopped before making adjustments, connections, or cleaning out PTO driven equipment.

Do not install any adapter device that results in a portion of the rotating implement shaft, tractor shaft, or the adapter to be unguarded. The tractor master shield should overlap the end of the splined shaft and the added adaptor device as outlined in the table.

## LOADER OPERATION

PTO Type	Diameter	Splines	$n \pm 0.2$ in. ( $n \pm 5$ mm)
1	1.378 in. (35 mm)	6	3.810 in. (97 mm)

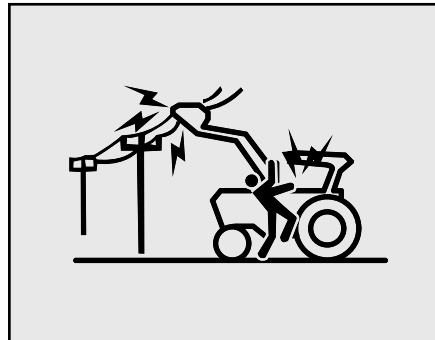
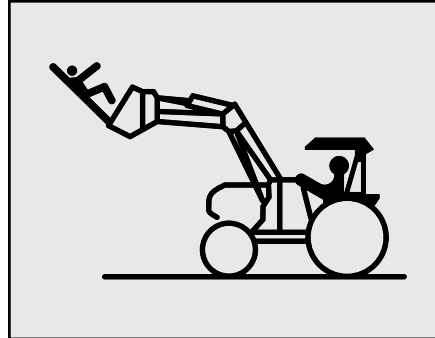

Work with front-end loader. (Risk of falling objects)

### WARNING

- Avoid contact with electrical power lines by loader or attachments.
- Do not lift or carry anyone in the bucket or on any other position of loader attachment.
- Inadvertent movement of the loader or attachment could result in serious injury or death from falling or crushing.



## CARRYING THE LOAD

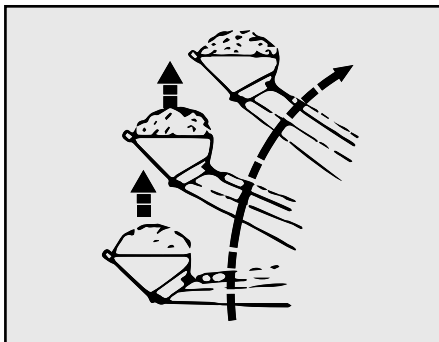

### ⚠ CAUTION

- Make sure material in bucket cannot roll out and down on tractor when bucket is raised to full height.
- Keep clear of overhead obstructions such as trees, limbs or power lines when raising bucket.
- When lifting the load, keep the bucket positioned to avoid spillage.

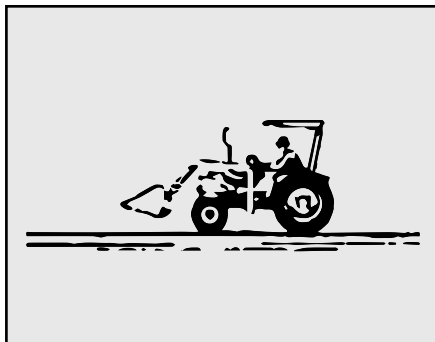

### ⚠ CAUTION

- Operating the loader on a hillside is dangerous. extreme care is recommended.

1. Position the bucket just below the level of the tractor hood for maximum stability and visibility, whether the bucket is loaded or empty.
2. Use extreme caution when operating the loader on a slope, keep the bucket as low as possible, this keeps the bucket and tractor center of gravity low and will provide maximum tractor stability.

## HANDLING LARGE HEAVY OBJECTS

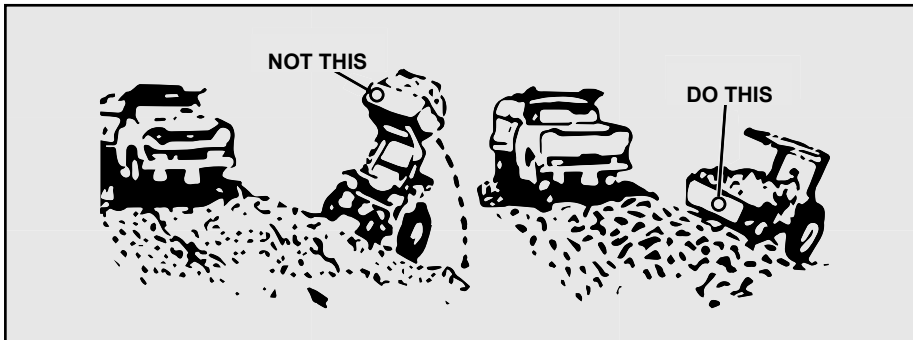
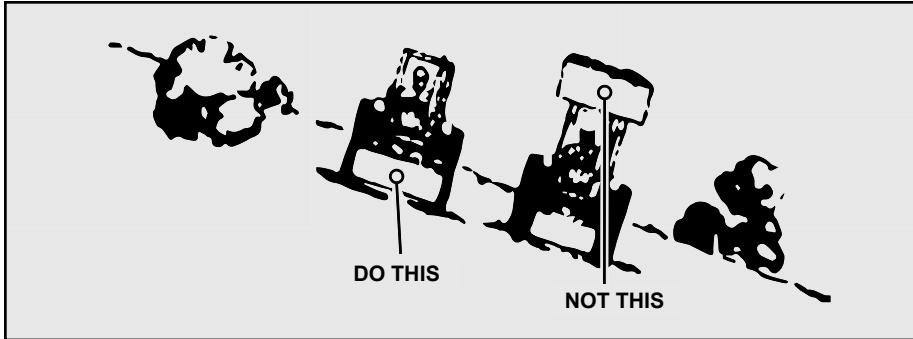

When transporting the load, keep the bucket as low as possible to avoid tipping, in case a wheel drops in a rut.

### ⚠ WARNING

- Do not use front end loaders for handling large, heavy objects such as large, round or rectangular bales, logs and oil drums.
- Handling large heavy objects can be extremely dangerous due to:
  1. Possibility of rolling the tractor over.
  2. Possibility of upending the tractor.
  3. Possibility of the object rolling or sliding down the loader arms onto the operator.

### ⚠ CAUTION

- When transporting the load, keep the bucket as low as possible to resist tipping, in case a wheel drops in a rut. This will avoid tipping and possible injury.

## ROPS FOLDING METHOD HOW TO FOLD DOWN THE ROPS

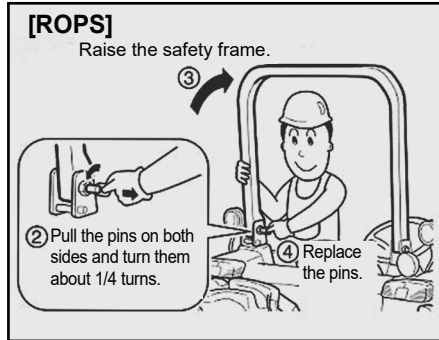

1. Turn the handle to separate the push plate and the ROPS.
  2. Pull the pins on both sides of the tractor and turn them about 1/4 turns to release the lock of the ROPS.
  3. Raise the ROPS a little.
  4. Replace the pin.
  5. Fold down the ROPS, and the pins will lock into place.
- ※ If it is not certain whether the pins are fixed, shake the frame a little bit to fix the pins for sure.

## HOW TO STAND UP THE ROPS

1. Pull the pins on both sides of the tractor and turn them about 1/4 turns to release the lock of the ROPS.
  2. Raise the ROPS a little.
  3. Replace the pins.
  4. Stand the ROPS up, and the pins will lock into place.
- ※ If it is not certain whether the pins are fixed, shake the ROPS a little bit to fix the pins for sure.
5. Turn the handle to fix the push plate and the frame.

### ⚠ CAUTION

- Don't fasten your seat belt after folding ROPS.
- When you drive tractor, fold up vertically.
- Fasten your seat belt after folding up ROPS.
- When working with the tractor, don't fold down ROPS.
- Don't change ROPS without authority.
- Before using tractor, check your ROPS support and other parts.
- If there is damage to the ROPS, change ROPS at once.

#### [Otherwise]

- If the tractor rolls over, you could be injured or death may occur.
- ※ ROPS are a very important structure for protection on roll over, always check your ROPS.

# 6. MAINTENANCE

<b>MAINTENANCE SCHEDULE CHART.....</b>	<b>6-2</b>	ADJUSTING PARKING BRAKE.....	6-15
<b>OIL, GREASE AND ANTI-FREEZE CHART .....</b>	<b>6-4</b>	PIPES AND HOSES .....	6-16
<b>FUEL, OIL AND COOLANT CHART .....</b>	<b>6-5</b>	ELECTRICAL CABLES .....	6-16
<b>OPENING HOOD.....</b>	<b>6-6</b>	GREASING.....	6-17
<b>CHECKING AND CHANGING OF OIL .....</b>	<b>6-6</b>	CLUTCH .....	6-17
ENGINE OIL .....	6-6	F-R SHUTTLE PEDAL.....	6-18
TRANSMISSION / HYD OIL FLUID.....	6-8	STEERING WHEEL.....	6-18
FRONT AXLE FLUID .....	6-9	BRAKE .....	6-19
<b>FILTERS / COOLANT REPLACEMENT .....</b>	<b>6-10</b>	FAN BELT .....	6-20
ENGINE OIL FILTER .....	6-10	AIR COMPRESSOR BELT .....	6-21
TRANSMISSION OIL FILTER.....	6-10	TOE-IN .....	6-21
FUEL FILTER .....	6-11	FUSE & FUSIBLE LINKS .....	6-22
DRAINING AIR IN FUEL LINE .....	6-11	CHECKING EXHAUST GAS .....	6-23
CHECKING AND ADDING FUEL .....	6-12		
COOLANT.....	6-12		
RADIATOR SCREEN AND AIR CLEANER.....	6-14		
BATTERY.....	6-14		
		<b>TIRES PRESSURE .....</b>	<b>6-23</b>

# MAINTENANCE SCHEDULE CHART

- ※ Check or adjust each part only when the engine is stopped.
- ※ When any hot part should be serviced, wait until it is cooled down.
- ※ Prioritize the interval of hour or year whichever it comes first.

- : Adjust · Check
- : Replace
- △ : Clean
- ★ : First time only  
(Replace/Clean/Check)

PART	ITEM	INTERVAL - HOUR											YEAR		REMARK		
		EVERY 50	EVERY 100	EVERY 150	EVERY 200	EVERY 250	EVERY 300	EVERY 350	EVERY 400	EVERY 450	EVERY 500	EVERY 2,000	EVERY 1	EVERY 2			
ENGINE	COOLANT LEVEL	CHECK BEFORE EVERY WORK															
	COOLANT															●	
	ENGINE OIL LEVEL	CHECK BEFORE EVERY WORK															
	ENGINE OIL & FILTER	★				●											
	FUEL FILTER										●						
	AIR CLEANER ELEMENT		△									●					
	RADIATOR & NET	CHECK BEFORE EVERY CLEAN															
	RADIATOR INSIDE	CLEAN WHEN COOLANT IS REPLACED															
	FAN BELT & AIR CONDITIONER BELT		○														REPLACE WHEN IT IS NEEDED
BATTERY		○														REPLACE WHEN IT IS NEEDED	
HOSS & BANDS	FUEL HOSE & BAND										○				●	REPLACE WHEN IT IS DAMAGED	
	AIR CLEANER HOSE & BAND										○				●	REPLACE WHEN IT IS DAMAGED	
	INLET HOSE & BAND										○				●	REPLACE WHEN IT IS DAMAGED	
	RADIATOR HOSE & BAND										○				●	REPLACE WHEN IT IS DAMAGED	

○ : Adjust · Check    △ : Clean  
 ● : Replace            ★ : First time only  
 (Replace/Clean/Check)

PART	ITEM	INTERVAL - HOUR											YEAR		REMARK	
		EVERY	EVERY	EVERY	EVERY	EVERY	EVERY	EVERY	EVERY	EVERY	EVERY	EVERY	EVERY	EVERY		
		50	100	150	200	250	300	350	400	450	500	2,000	1	2		
T/M	TRANSMISSION OIL	★			●											FIRST 50 HR REPLACE
	HST OIL FILTER	★							●							
	SUCTION FILTER	★			●											
OTHERS	FRONT AXLE OIL	★			●											
	BOLTS & NUTS	CHECK BEFORE EVERY WORK														
	CLUTCH PEDAL FREE PLAY	CHECK BEFORE EVERY WORK														
	BRAKE PEDAL FREE PLAY	CHECK BEFORE EVERY WORK														
	FRONT REAR WHEEL	CHECK BEFORE EVERY WORK														
	GREASING EACH PART	○														GREASING WHEN EVERY WATERY WORK
	THROTTLE SYSTEM							○								
	ELECTRIC WIRING	○														REPLACE WHEN IT IS DAMAGED
TOE-IN							○								GET SERVICED AT WORKSHOP	

## OIL, GREASE AND ANTI-FREEZE CHART

NO	ITEM	TYPE	REMARK
1	Fuel	Diesel (Summer : S, Winter : W)	Use winter diesel when temperature in below 50°F
2	Engine oil	SAE 15W-40	
3	Grease	Arctic Grease Below 14°F (-10°C) SAE (NLGI) #0, #1 32 ~ -22°F (0~-30°C) SAE (NLGI) #2 32 ~ 122°F (0~50°C)	
4	Coolant Anti - Freeze	ASTM D4985 Extended Life antifreeze	
5	Transmission / Hydraulic oil	BAD BOY Origin Oil Texaco TDH oil, 1893	
6	Front axle oil	SAE 80W-90	



### WARNING

- Check the oil level regularly. Correct the oil level, if needed, before operating.
- Always check and add oil with the tractor on a flat, level surface.

## FUEL, OIL AND COOLANT CHART

NO	ITEM	CAPACITY		REMARK
		CABIN	ROPS	
1	Fuel	12.00 gal (45.00 L)	12.00 gal (45.00 L)	
2	Engine oil	1.20 gal (4.50 L)	1.20 gal (4.50 L)	
3	Coolant	1.56 gal (5.90 L)	2.08 gal (7.90 L)	
4	Transmission / Hydraulic oil	10.04 gal (38.00 L)	10.04 gal (38.00 L)	
5	Front axle	1.90 gal (7.00 L)	1.90 gal (7.00 L)	

**⊕ IMPORTANT**

- Above listed fuel, oil and coolant table is only for initial filling, and may be reduced at the time of replace.



## OPENING HOOD

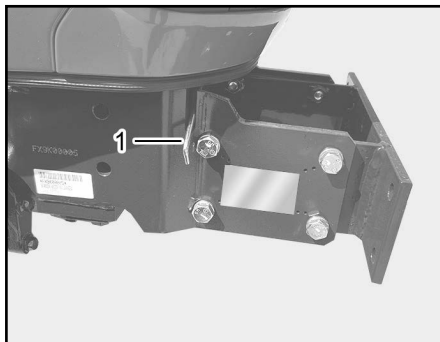

(1) Opening Lever

1. The hood can be unlocked by pulling the opening lever.
2. Slightly lift the hood with both hands and the hood is automatically lifted by the gas spring.
3. To close the hood, press its front down slightly until a “click” sound is heard.
4. After closing the hood, lift it to check that the hood is securely fixed.

## CHECKING AND CHANGING OF OIL

Do not dispose of waste oils in waterways or in the sewage system, and take appropriate measures such as contacting a waste oil disposal specialist.

### **⚠ DANGER**

- Never fill the fuel tank when the engine is running or hot.

[Otherwise]

There is a danger of fire.

### **⚠ CAUTION**

- Do not change the oil right after stopping the engine.

[Otherwise]

There is a danger of getting burnt.

## ENGINE OIL

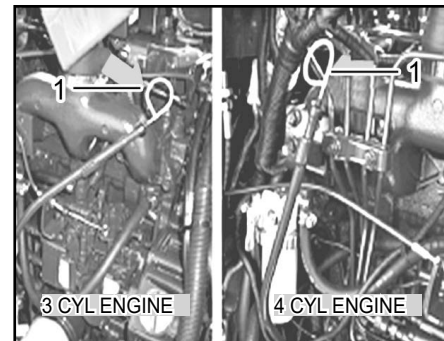

(1) Dipstick

### ► CHECKING OIL

Pull out the dipstick, clean the tip of dipstick, put it back into the engine, and pull it out again to see if the oil level is between the upper and lower limit. If the oil level is below the lower limit, add oil.

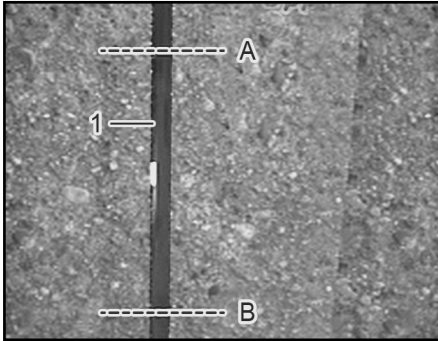

(1) Dipstick  
 (A) Upper Limit (B) Lower Limit

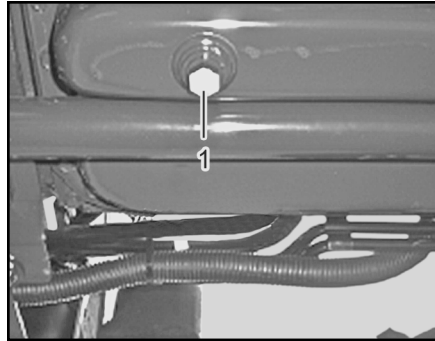

(1) Drain Plug

 <b>CAUTION</b>
<ul style="list-style-type: none"> <li>• Drain the oil when oil is warm but be careful. If oil is hot, there is a risk of getting burnt.</li> </ul>

 <b>CAUTION</b>
<ul style="list-style-type: none"> <li>• Check the oil level before the engine is started or after the engine is cooled down.</li> </ul>

**► CHANGING OIL**  
 Drain the oil by removing the plug under the engine. Put new oil through the engine oil filler hole. Change the oil periodically, and select the right type of oil depending on the temperature and usage.

<b>NOTE</b>
<ul style="list-style-type: none"> <li>• First 50HR engine oil has to be changed.</li> </ul>

## TRANSMISSION / HYD OIL FLUID

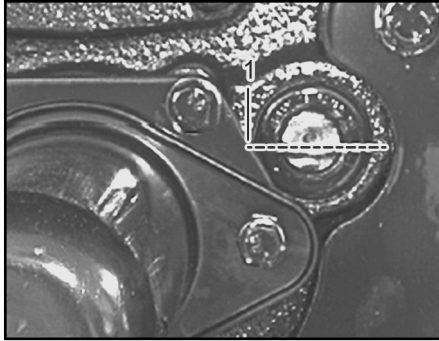

(1) Inspection Window

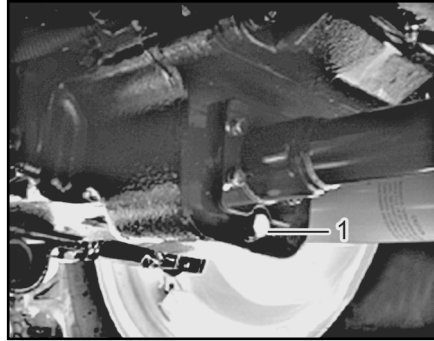

(1) Drain Plug

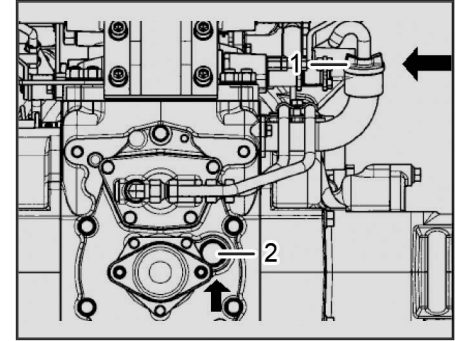

(1) Oil Filler

(2) Inspection Window

### ► CHECKING OIL

Check the fluid level through the inspection window at the rear side of the transmission compartment.

The level should be 1/3 above in upper window. If the fluid level is below proper level, add fluid

### ► CHANGING OIL

Drain the fluid through the drain holes under the rear axle case and rear axle housing. Supply the fluid through the filler hole behind the hydraulic case.

1. Transmission oil can be used for the hydraulic system and for the power steering unit.
2. Make sure to use the genuine BAD BOY transmission fluid.

### ▲ CAUTION

- Drain the oil when oil is warm but be careful. If oil is hot, there is a risk of getting burnt.

### NOTE

- First 50HR transmission fluid has to be changed.

## FRONT AXLE FLUID

**⚠ DANGER**

- Be sure to turn “OFF” the main (ignition) key to stop the engine before pulling out the oil dipstick.

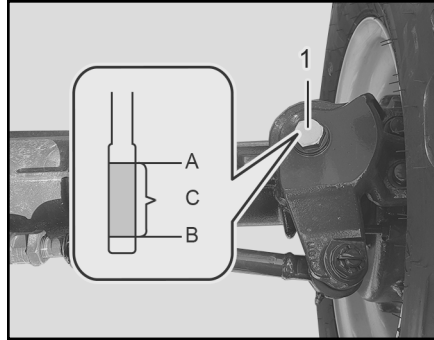

(1) Front Axle Oil

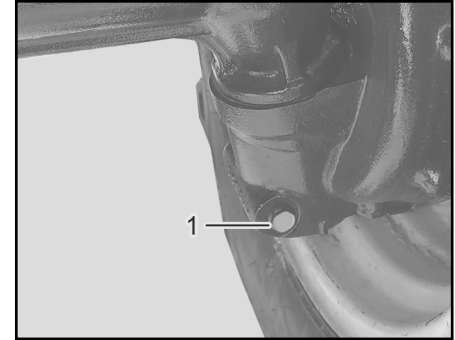

(1) Drain Plug

### ► CHECKING

Unscrew the oil filler plugs on the left sides of the front axle housing, wipe them clean, and then insert them into their original position. Then, pull them out again and check if the oil level is within the specified range. If the oil level is too low, add some new oil so that the level is within the allowable range. Also, check for leakage.

### ► CHANGING OIL

Drain the fluid through the drain holes under the front axle.

Refill the fluid through fluid filler at the upper right side of the front axle.

**NOTE**

- First 50HR front axle oil has to be changed.

## FILTERS / COOLANT REPLACEMENT

### ENGINE OIL FILTER

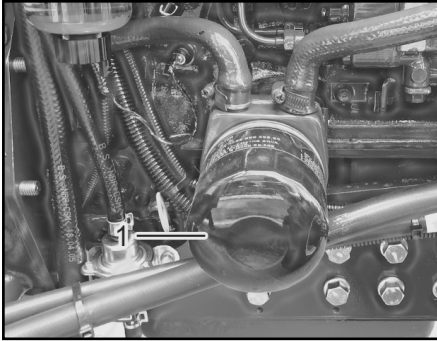

(1) Engine Oil Filter

Replace it every 250 hours or when engine oil is changed.

#### NOTE

- First 50 hours, filter has to be changed.

#### ► REPLACEMENT

1. After draining the engine oil, turn the cartridge to the left with the filter wrench.
2. Apply a thin film of oil over the rubber ring on the bottom of the new cartridge and attach the new filter securely.
3. After changing the engine oil, start the engine and run it until the engine oil pressure warning lamp is turned off .
4. After the oil pressure warning lamp is turned off, check the oil level again. Add oil as necessary.

### TRANSMISSION OIL FILTER

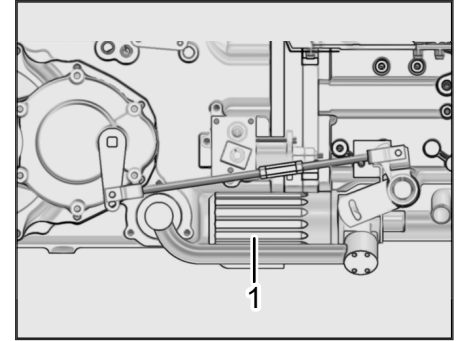

(1) Transmission Oil Filter

The filter is a cartridge type.

#### NOTE

- First 50 hours, filter has to be changed.

### ► REPLACEMENT

1. After draining the transmission fluid, turn the cartridge to the left to take it out.
2. Apply a thin film of fluid over the rubber ring on the bottom of the new cartridge and attach the new filter securely.
3. After changing the transmission fluid, start the engine to circulate the fluid and then stop the engine. Check the fluid level through the inspection window at rear side of transmission and add fluid as necessary.

### FUEL FILTER

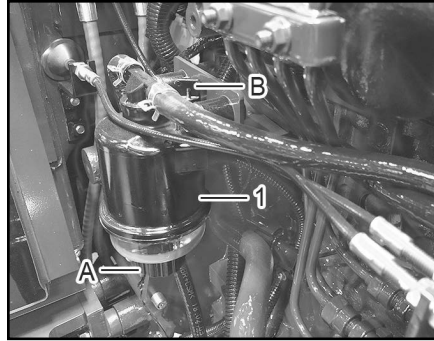

(1) Fuel Filter  
 (A) Water Drain cock (B) Air Drain Cock

Remove the water in the fuel filter When the plastic floater floats on the water.

1. Open the "A" Position.
  2. Drain the water that has settled to the bottom.
  3. Close the "A" Position.
- ※ When the water cannot be drained,  
 Open the "B" position.
- ※ This fuel filter cannot remove the element from the fuel filter body.

### DRAINING AIR IN FUEL LINE

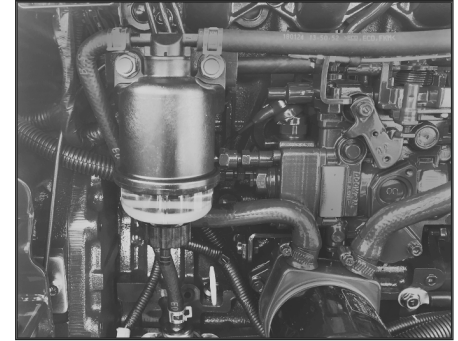

Drain the air from the fuel tank, fuel filter, and fuel filter element when the engine stops as the fuel runs out or during maintenance.

1. Refill fuel to fuel tank.
2. The key switch to "ON" until the 10 seconds in order that feed pump sucks up the fuel.
3. Put the throttle lever to "MAX" and the key switch to "START" to run the starting motor for about 10 seconds. That completes the procedure.

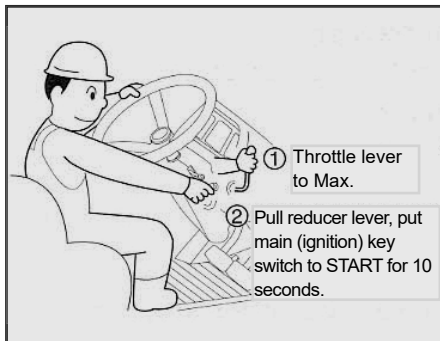

## CHECKING AND ADDING FUEL

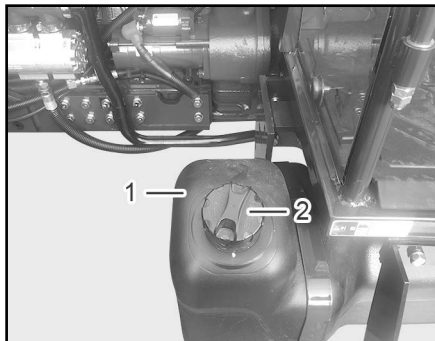

(1) Fuel tank

(2) Fuel cap

## COOLANT

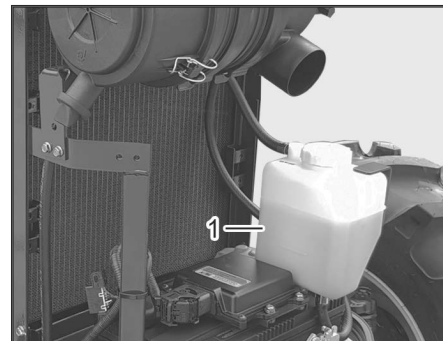

(1) Coolant Tank

### NOTE

- If air is not removed, then there will be air in the fuel lines. Please check fuel lines for leakage or breakage.

Turn the main (ignition) key switch to the "ON" position. If the fuel gauge needle is pointing the red area, open the fuel cap, and then fill the fuel tank. And check if there is leakage.

### DANGER

- Never smoke or use a lighter while refueling the tractor.
- After refueling, securely close the fuel cap and wipe off any spilled fuel.

### ► CHECKING

Open the engine hood and see if the water level in the reservoir is between the upper and lower limit. Add clean water as necessary.

### ► REPLACEMENT

1. Open the radiator cap and the drain plug to completely drain the water from the radiator.

2. Rinse the radiator with tap water until no dirt or rust comes out.
- ※ For better results, fill the radiator with water mixed with radiator flush, run the engine for over 15 minutes, and drain the water solution
3. Assemble the drain plug, add anti-freeze and fill the radiator with tap water.
4. Assemble the radiator cap and run the engine to mix the anti-freeze and water.

**⚠ DANGER**

- Do not open the radiator cap while the engine is running or right after the engine is stopped. Open the radiator cap only after the engine is stopped and fully cooled down.

[Otherwise]

Hot water will splash and may cause burn injury.

**▶ HANDLING OF ANTI-FREEZE**

Anti-freeze has an effect of lowering the freezing point of water. This tractor is filled with international genuine anti-freeze when delivered from the factory. As the freezing point may differ depending on the mixture ratio, refer to the following table in very cold weather to ensure safety.

**▶ ANTI-FREEZE MIXTURE RATIO**

<b>Outdoor Temp (°F)</b>	23	14	5	-4	-13	-22
<b>Water (%)</b>	82	73	66	61	55	49
<b>Anti-Freeze (%)</b>	18	27	34	39	45	51

**⚠ CAUTION**

- When replacing the coolant, add anti-corrosive solution and run the engine for about five minutes to mix it with the water.
- For correct mixture ratio, refer to the manufacturer's instructions.
- When refilling the coolant, add only tap water.
- As anti-freeze expires in one year, replace the coolant every year.



## RADIATOR SCREEN AND AIR CLEANER

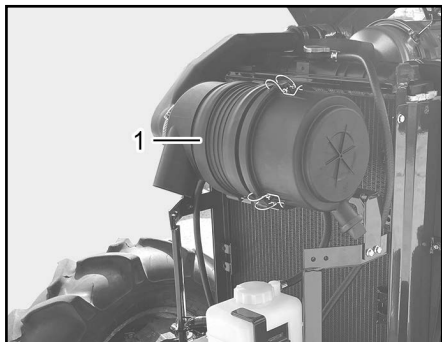

(1) Air Cleaner

The Air cleaner removes the dust mixed in the intake air, thereby preventing abrasion of cylinder liners and piston rings to keep the engine in good condition. When working in dusty environments clean the air filter every 50 hours and replace it every 400 hours.

In normal working environments, clean the air filter every 100 hours and replace it every 500 hours. If the running hours are shorter, replace the element after one year.

### ► CLEANING OF AIR CLEANER

Open the cover and take out the element. Blow air inside the element or shake it to take the dust off the element. Be careful to avoid damage to the pins.

### ► CLEANING OF RADIATOR SCREEN

Pull out the air cleaner fixing band for radiator disassembly. Pull up the radiator cleaner in the direction of arrow mark and unfold it upward and pull out upward.

Remove straw and dust. Clean it before and after work.

## BATTERY



1. When replacing the battery, make sure to install the battery of the same capacity as designated in the instruction manual.
2. To preserve the environment and to recycle resources, do not discard the old battery and hand it over to the battery dealer for proper disposal.

## ADJUSTING PARKING BRAKE

### DANGER

- Avoid heat when checking or charging the battery.

[Otherwise]

The battery may explode and cause burns or other injury.

### CAUTION

- When connecting the battery cable, connect the (+) terminal first. When disconnecting the cable, disconnect the (-) terminal first.

[Otherwise]

There is a risk of getting burnt due to shorting of the battery.

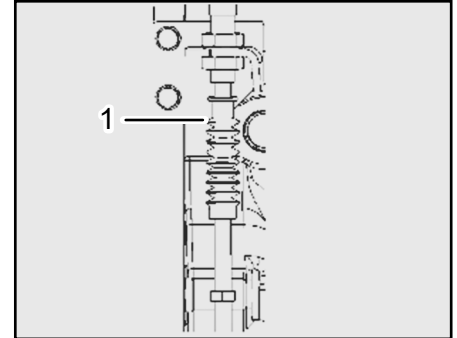
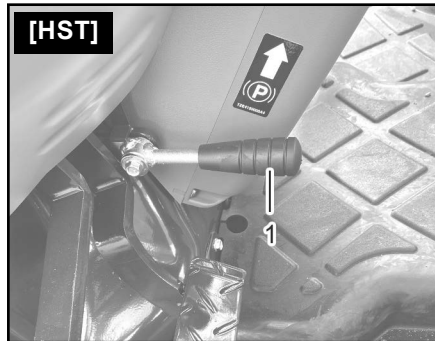
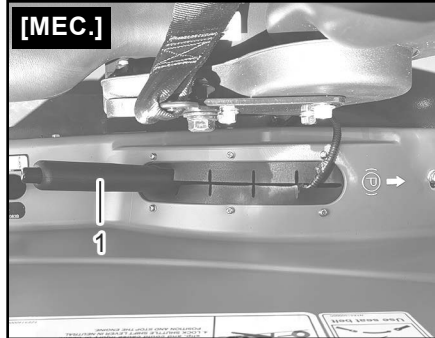

(1) Parking Brake Cable

2. Tighten fixing nuts of parking brake cable and fix them at position where clearance amount is 0.8 ~ 1.0 in. (20 ~ 25 mm) from the end of parking brake lever.

(1) Parking Brake Lever

1. Unscrew fixing nuts of parking brake cable with parking brake released.

## PIPES AND HOSES

Check for damage to fuel hoses, power steering hoses (pipe), and radiator hoses, and see if there is any leakage or loosening of bolts.

Replace the pipes and hoses every two years even though they are not damaged.

 **CAUTION**

- When replacing the fuel hose, drain air.

 **DANGER**

- Inspect the condition of the fuel hoses and check for fuel leakage from any damaged parts of the hoses.

[Otherwise]

There is a risk of fire.

## ELECTRICAL CABLES

Open the hood of the engine and check if any cable is in contact with other parts, or if any insulation is peeled off or damaged, or any contact is loosened.

Damaged cables must be repaired by an authorized dealer. Arrange for periodic maintenance for cables every 50 hours or once a year even though the cables are not damaged.

 **DANGER**

- Before starting to work everyday, check if any cable is in contact with other parts, or if any insulation is peeled off or damaged, or any contact is loosened.
- Before and after work, remove any straw or dust on the battery or cables.

## GREASING

Apply grease every 50 hours. Check the relevant parts before starting work everyday and add grease as necessary. After working on wet areas, make sure to apply grease to the tractor.

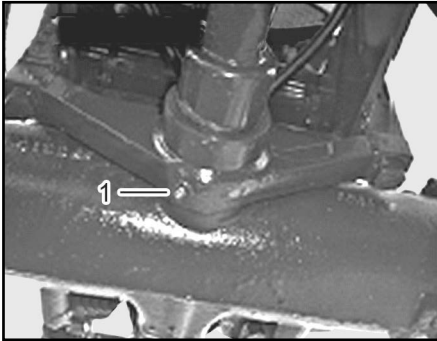

(1) Front Axle Support

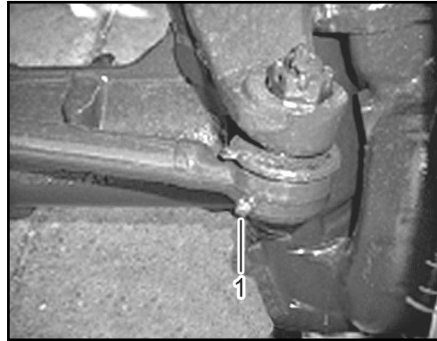

(1) Tie Rod LH / RH

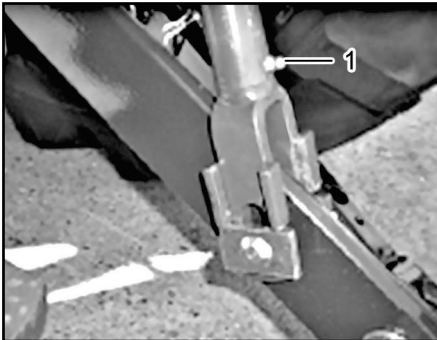

(1) Lift Rod (R)

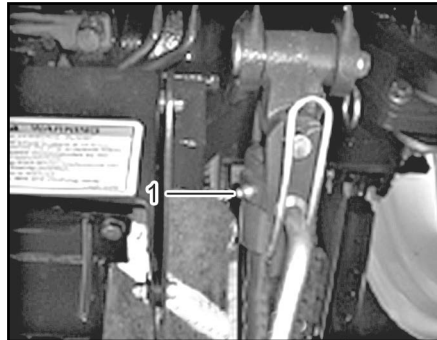

(1) Lift Rod (L)

## CLUTCH

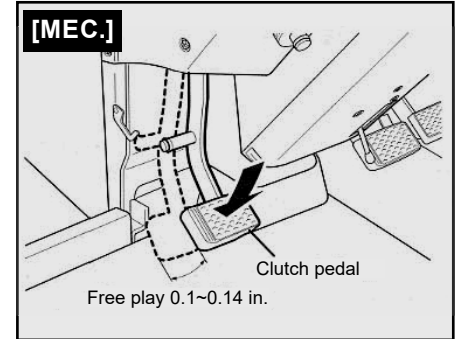

- (1) Clutch Pedal
- (A) Free Play : 0.1 ~ 1.4 in.

Depress the clutch pedal and check if the free play is as required. If not, adjust the free play with the stopper bolt and cable. After you adjust free play, make sure to re-tighten the retaining nut.

## F-R SHUTTLE PEDAL(HST)

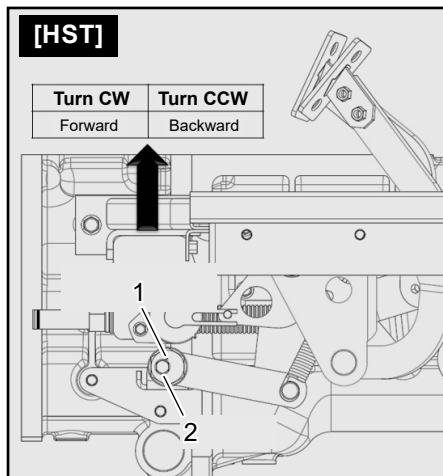

(1) Neutral Adjust Shaft (B) Fix Bolt

When machine moves without depressing F-R shuttle pedal, adjust as below F-R shuttle pedal adjustment procedure.

1. Release fix bolt
2. Turn neutral shaft slightly to CW or CCW (CW – Forward, CCW – Backward)
3. Tighten fix bolt.

4. Run engine and check moving without F-R shuttle pedal operation.
5. If machine should move after adjustment, repeat 1 to 4 steps.

## STEERING WHEEL

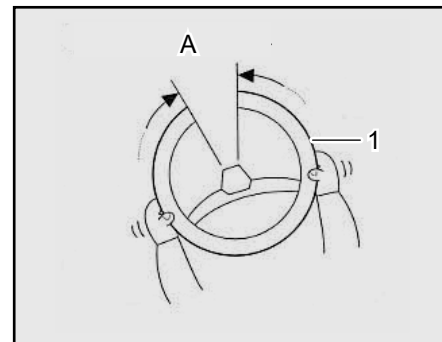

(1) Steering Handle  
(A) Free Play : 0.8~ 2.0 in.

When the steering wheel is turned lightly, there should be free play 0.8 ~ 2.0 in. If the extent of the free play exceeds this range, the steering wheel may feel heavy or the tractor may not move straight. If the free play is not normal, have it fixed at your nearest authorized dealer.

## BRAKE

**⚠ WARNING**

- Make sure that the steering wheel does not vibrate severely or has enough free play. Otherwise, there is a risk of accident.

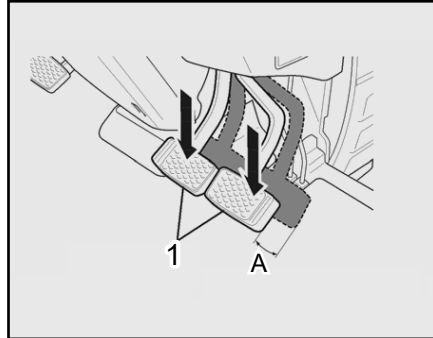

- (1) Brake Pedal  
 (A) Free Play : 0.2 ~ 0.4 in.

- In this case, the free play of the brake pedal is 0.2 ~ 0.4 in.
- Adjust both of the brake pedals.

**⚠ WARNING**

- Check the brakes to avoid one-sided braking. Otherwise, there is a risk of accident.
- If the extent of free play different between the two brakes pedals, one-sided braking will occur. Make sure that the free play of both brake pedals is the same.

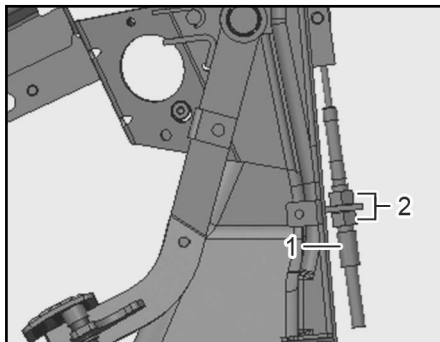

(1) Brake Rod  
(2) Nut

#### ► HOW TO ADJUST BRAKE FREE PLAY

1. Remove dashboard.
2. Loosen fixing nut.
3. Adjust stopper bolt so that the gap between bolt head and brake pedal arm is 0 ~ 0.02 in.
4. Tighten the fixing nut.
5. After removing right side of dashboard, loosen fixing nut and adjust stopper bolt so that the gap between stopper bolt head and brake pedal arm is 0 ~ 0.02 in. and tighten the fixing nut again.

#### FAN BELT

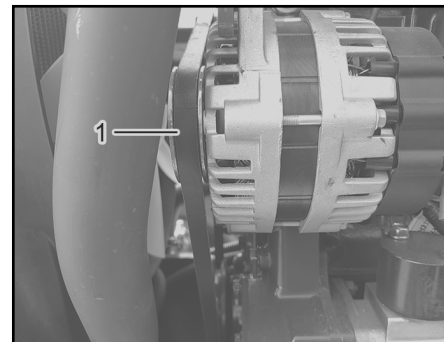

(1) Fan Belt

Open the engine hood and press the middle of fan belt with finger to see if the belt sags about 0.4 ~ 0.6 in. or if there is any damage to the belt. If the sagging is not correct, loosen the generator bolt and move the generator to adjust the tension of the fan belt. If the fan belt still slips after the generator is moved to the maximum, replace the belt with a new one. New belts must be inspected after 50 hours of use.

**⚠ CAUTION**

- Carry out inspection or maintenance after the engine is fully cooled down.

[Otherwise]

There is a risk of getting burnt.

**AIR COMPRESSOR BELT**

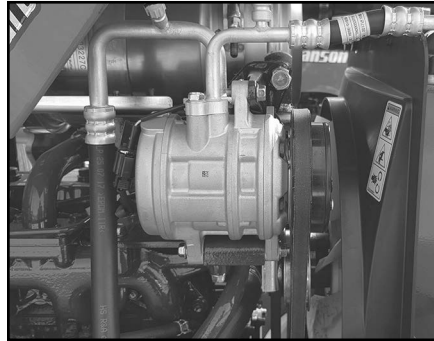

(1) Air Compressor Belt

Check if belt is sagging for about 0.39 ~ 0.60 in. or check for any damage to the belt by opening bonnet and engine side cover and pressing the middle of fan belt.

When it is not sagging enough, adjust tension by using adjusting bolt at the front of compressor.

Change the belt when tension cannot be adjusted even when the bolt is tightened as much as possible.

**TOE-IN**

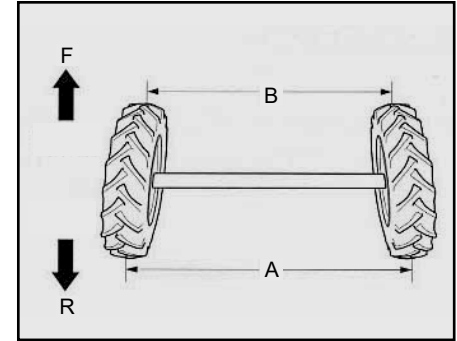

(F) Front

(R) Rear

**► CHECKING**

If the toe-in is not properly aligned, the steering wheel may be uncontrollable or the tractor may produce an abnormal vibration. Measure the distance A and the distance B of the front wheels and see if the different between the two measurements is 0.16 ~ 0.30 in.



## FUSE & FUSIBLE LINKS

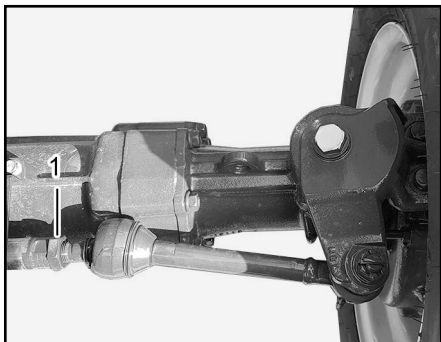

(1) Nut

### ► ADJUSTING

If not, loosen nuts at the end of the cylinder rod on both sides and adjust the length of the screws. Tighten the nuts when the toe-in is 0.16 ~ 0.30 in.

Left and right adjustment of screw length must be same.

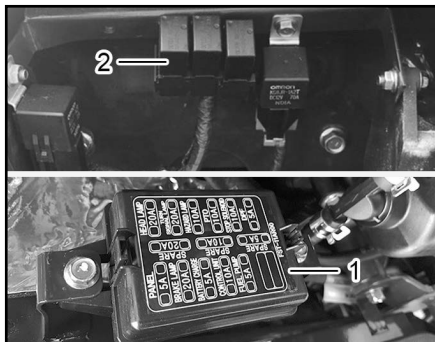

(1) Main Fuse

(2) Relay Box

Stop the engine and check the main fuse. (Fusible link)

Open the fuse box cover and check the fuses. Replace any burnt-out fuses with new ones of required capacity.

A fusible link is a type of fuse, which burns and disconnects the current in the event of excessive current flowing in the circuit, if plastic coating is discolored when it is cut off, it should be inspected by a authorized dealer.

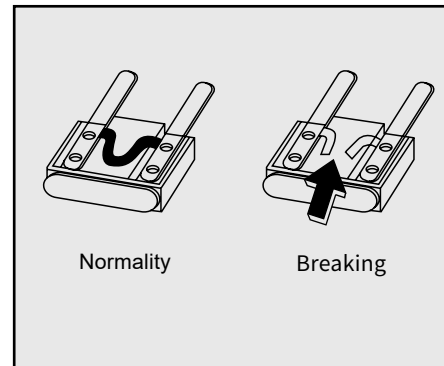

(1) Fusible Links

If the fuse burns immediately after being replaced, it must be checked by the authorized dealer.

### **WARNING**

- When replacing the fuse, use only the one of the same capacity.

## TIRES PRESSURE

### CHECKING EXHAUST GAS

The exhaust gas may be a little black at the time of starting the engine, but normally its color is clear.

- Black – incomplete combustion due to too much fuel intake.
- White – misfiring or cold temperature.
- Blue – burning of engine oil

If the color of the exhaust gas remains black or white during operation, have the tractor inspected at your nearest authorized dealer.

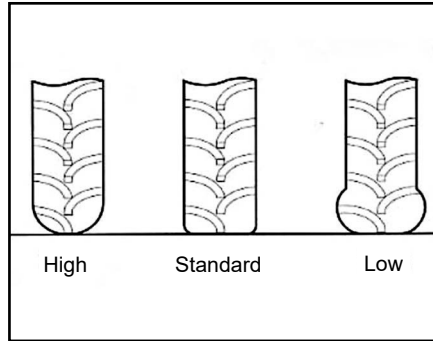

Adjust air pressure in front and rear tires to standard pressure.

Also, check if there are any cracks on the tires. When front wheels are put under a load of the front weights or a front loader, air pressure in the front wheels must be adjusted to the maximum in the chart as followed.

### ► AIR PRESSURE IN TIRES

		Air pressure (psi)
With Implement	Front	29
	Rear	19
With loader	Front	44
	Rear	29

### ► TORQUE OF WHEEL BOLTS

Type	Torque (lb-ft)
Front wheel	130 ~ 145
Rear wheel	130 ~ 145

# MEMO

A series of horizontal dotted lines for writing.

# 7. TROUBLESHOOTING

TRUBLESHOOTING - ENGINE .....	7-2
TRUBLESHOOTING - CLUTCH AND BRAKE.....	7-5
TRUBLESHOOTING - HYDRAULIC SYSTEM.....	7-6
TRUBLESHOOTING - ELECTRICAL SYSTEM .....	7-7

## TROUBLESHOOTING - ENGINE

Symptom	Inspection item	Action
1. The starter motor does not start when the main (ignition) key switch is turned to "START".	<ul style="list-style-type: none"> <li>Is the clutch depressed?</li> </ul>	<ul style="list-style-type: none"> <li>Depress the clutch pedal fully and turn the main (ignition) key switch to the "START" position.</li> </ul>
	<ul style="list-style-type: none"> <li>Is the battery discharged?</li> </ul>	<ul style="list-style-type: none"> <li>Charge the battery.</li> </ul>
	<ul style="list-style-type: none"> <li>Is the battery terminal loosened or corroded?</li> </ul>	<ul style="list-style-type: none"> <li>Clean and tighten the terminals.</li> </ul>
	<ul style="list-style-type: none"> <li>Is the main fuse blown out?</li> </ul>	<ul style="list-style-type: none"> <li>Replace the fuse.</li> </ul>
	<ul style="list-style-type: none"> <li>Is the main (ignition) key switch broken?</li> </ul>	<ul style="list-style-type: none"> <li>Contact the dealer for repair or replacement.</li> </ul>
	<ul style="list-style-type: none"> <li>Is the starter motor damaged?</li> </ul>	<ul style="list-style-type: none"> <li>Contact the dealer for repair or replacement.</li> </ul>
2. The starter motor runs, but the engine does not start.	<ul style="list-style-type: none"> <li>Is the fuel tank empty?</li> </ul>	<ul style="list-style-type: none"> <li>Fill up the fuel tank and bleed the system.</li> </ul>
	<ul style="list-style-type: none"> <li>Is the fuel mixed with air?</li> </ul>	<ul style="list-style-type: none"> <li>Bleed the fuel system.</li> </ul>
3. The engine revolution is irregular.	<ul style="list-style-type: none"> <li>Is air mixed in the fuel system?</li> </ul>	<ul style="list-style-type: none"> <li>Bleed the fuel system.</li> </ul>
	<ul style="list-style-type: none"> <li>Is water mixed in the fuel?</li> </ul>	<ul style="list-style-type: none"> <li>Drain water and replace fuel.</li> </ul>
	<ul style="list-style-type: none"> <li>Is the injection nozzle clogged?</li> </ul>	<ul style="list-style-type: none"> <li>Contact the dealer for repair or replacement.</li> </ul>
	<ul style="list-style-type: none"> <li>Is the fuel filter clogged?</li> </ul>	<ul style="list-style-type: none"> <li>Clean or replace it.</li> </ul>

Symptom	Inspection item	Action
4. The engine is overheated.	<ul style="list-style-type: none"> <li>• Is the coolant level low?</li> </ul>	<ul style="list-style-type: none"> <li>• Refill the coolant.</li> </ul>
	<ul style="list-style-type: none"> <li>• Is the fan belt loosened or damaged?</li> </ul>	<ul style="list-style-type: none"> <li>• Adjust the belt tension or replace it.</li> </ul>
	<ul style="list-style-type: none"> <li>• Is the radiator fin clogged?</li> </ul>	<ul style="list-style-type: none"> <li>• Clean it.</li> </ul>
	<ul style="list-style-type: none"> <li>• Is the engine oil level low?</li> </ul>	<ul style="list-style-type: none"> <li>• Refill the engine oil.</li> </ul>
	<ul style="list-style-type: none"> <li>• Is the engine running under overload?</li> </ul>	<ul style="list-style-type: none"> <li>• Reduce the load.</li> </ul>
5. The engine power is too weak.	<ul style="list-style-type: none"> <li>• Is the air cleaner clogged?</li> </ul>	<ul style="list-style-type: none"> <li>• Inspect the air cleaner and replace the element.</li> </ul>
	<ul style="list-style-type: none"> <li>• Is the nozzle damaged?</li> </ul>	<ul style="list-style-type: none"> <li>• Contact the dealer for repair.</li> </ul>
	<ul style="list-style-type: none"> <li>• Is the compression force weak?</li> </ul>	<ul style="list-style-type: none"> <li>• Contact the dealer for repair.</li> </ul>
	<ul style="list-style-type: none"> <li>• Is the valve clearance adjusted properly?</li> </ul>	<ul style="list-style-type: none"> <li>• Contact the dealer for repair.</li> </ul>
	<ul style="list-style-type: none"> <li>• Is the injection timing incorrect?</li> </ul>	<ul style="list-style-type: none"> <li>• Contact the dealer for repair.</li> </ul>

Symptom	Inspection item	Action
6. The coolant warning lamp was turned "ON" during operation.	<ul style="list-style-type: none"><li>• Is the coolant level in the reservoir tank low?</li></ul>	<ul style="list-style-type: none"><li>• Refill the coolant.</li></ul>
7. The engine oil pressure lamp is turned "ON" during operation.	<ul style="list-style-type: none"><li>• Is the engine oil level low?</li></ul>	<ul style="list-style-type: none"><li>• Refill the engine oil up to required level.</li></ul>
	<ul style="list-style-type: none"><li>• Is the viscosity of the engine oil low?</li></ul>	<ul style="list-style-type: none"><li>• Replace the engine oil with proper viscosity.</li></ul>
	<ul style="list-style-type: none"><li>• Is the pressure switch defective?</li></ul>	<ul style="list-style-type: none"><li>• Replace the switch.</li></ul>
	<ul style="list-style-type: none"><li>• Is the oil pump defective?</li></ul>	<ul style="list-style-type: none"><li>• Contact the dealer for repair.</li></ul>
8. The battery charge warning lamp is turned "ON" during operation.	<ul style="list-style-type: none"><li>• Is the alternator defective?</li></ul>	<ul style="list-style-type: none"><li>• Contact the dealer for repair.</li></ul>
	<ul style="list-style-type: none"><li>• Is the fan belt loosened or damaged?</li></ul>	<ul style="list-style-type: none"><li>• Adjust the fan belt tension or replace it.</li></ul>

## TROUBLESHOOTING - CLUTCH AND BRAKE

Symptom	Inspection item	Action
1. The clutch slips or does not be disengaged.	<ul style="list-style-type: none"><li>• Is the free play of clutch pedal proper?</li></ul>	<ul style="list-style-type: none"><li>• Adjust the free play of the pedals.</li></ul>
2. The brake does not work or works only on one side.	<ul style="list-style-type: none"><li>• Is the free play of the brake pedals proper?</li></ul>	<ul style="list-style-type: none"><li>• Adjust the free play of the pedals.</li></ul>
3. The brake pedal does not return to its original position properly and it makes a noise.	<ul style="list-style-type: none"><li>• Is the brake pedal return spring damaged?</li></ul>	<ul style="list-style-type: none"><li>• Replace the spring.</li></ul>
	<ul style="list-style-type: none"><li>• Is each sliding part well greased?</li></ul>	<ul style="list-style-type: none"><li>• Remove the rust and apply grease.</li></ul>



## TROUBLESHOOTING - HYDRAULIC SYSTEM

Symptom	Inspection item	Action
1. The implement does not be lifted.	<ul style="list-style-type: none"> <li>Is the hydraulic flow control dial in the close position?</li> </ul>	<ul style="list-style-type: none"> <li>Adjust the hydraulic flow control dial.</li> </ul>
	<ul style="list-style-type: none"> <li>Is the transmission oil level low?</li> </ul>	<ul style="list-style-type: none"> <li>Refill the transmission oil.</li> </ul>
	<ul style="list-style-type: none"> <li>Is the air taken in the fluid suction system?</li> </ul>	<ul style="list-style-type: none"> <li>Tighten the filter or connection parts. Replace the pipe or O-ring if damaged.</li> </ul>
	<ul style="list-style-type: none"> <li>Is the oil filter clogged?</li> </ul>	<ul style="list-style-type: none"> <li>Clean or replace it.</li> </ul>
	<ul style="list-style-type: none"> <li>Is the Selective control valve lever in the detent position?</li> </ul>	<ul style="list-style-type: none"> <li>Put the Selective control valve lever in the neutral position.</li> </ul>
	<ul style="list-style-type: none"> <li>Is the hydraulic pump defective?</li> </ul>	<ul style="list-style-type: none"> <li>Contact the dealer for repair.</li> </ul>
	<ul style="list-style-type: none"> <li>Is the cylinder damaged?</li> </ul>	<ul style="list-style-type: none"> <li>Contact the dealer for repair.</li> </ul>
2. The implement does not be lowered.	<ul style="list-style-type: none"> <li>Is the hydraulic flow control dial in the close position?</li> </ul>	<ul style="list-style-type: none"> <li>Adjust the hydraulic flow control dial.</li> </ul>
	<ul style="list-style-type: none"> <li>Is the position control lever on the lowest position?</li> </ul>	<ul style="list-style-type: none"> <li>Move the position control lever.</li> </ul>
	<ul style="list-style-type: none"> <li>The implement cannot be lowered even though the position control lever is placed in the lowest position.</li> </ul>	<ul style="list-style-type: none"> <li>Contact the dealer for repair.</li> </ul>

## TROUBLESHOOTING - ELECTRIC SYSTEM

Symptom	Inspection item	Action
1. The head lamp does not turn "ON".	• Is the bulb blown?	• Replace the bulb.
	• Is the fuse blown?	• Replace the fuse.
	• Is the cable connector separated from the socket?	• Inspect it.
	• Is the contact in a poor condition?	• Inspect and clean the grounding and terminals.
2. The turn signal lamp does not come "ON".	• Is the bulb blown?	• Replace the bulb.
	• Is the fuse blown?	• Replace the fuse.
	• Is the cable connector separated from the socket?	• Inspect it.
	• Is the contact in a poor condition?	• Inspect and clean the grounding and terminals.
3. The other lamp does not turn "ON".	• Is the bulb blown?	• Replace the bulb.
	• Is the fuse blown?	• Replace the fuse.
	• Is the cable in a poor contact?	• Inspect the cable and secure the contact.
	• Is the switch defective?	• Replace the switch.

# MEMO

A series of horizontal dotted lines for writing.

## 8. STORAGE AND DISPOSAL

DAILY STORAGE .....	8-2
LONG-TERM STORAGE .....	8-3
OPERATING TRACTOR AFTER LONG-TERM STORAGE .....	8-6
USAGE AND DISPOSAL.....	8-7

## DAILY STORAGE



After work, clean the tractor and dry the moisture and supply grease into each grease nipple.

Avoid water on electrical parts whenever possible, as it will cause equipment breakdown.

1. Store the tractor after cleaning it. Especially, clean it thoroughly after harrowing or working in a wet field.
2. Be sure to lower the implement.
3. Store it indoors if possible. If it should be kept outside, cover it.



### CAUTION

- Unless the battery is removed from the vehicle, make sure to disconnect the negative(-) battery cable. The wiring can be gnawed by rodents, leading to a fire.

4. Remove the battery from the tractor in winter and store it indoors for easy starting.
5. Add anti-freeze to the tractor in winter season in order to prevent the radiator from freezing.
6. Remove the main (ignition) key and store it separately.



### DANGER

- When covering the tractor, make sure that the engine or the muffler has fully cooled down.

[Otherwise]

There is a risk of fire.



### CAUTION

- When carrying out checking, maintenance, or repair, make sure to turn off the engine.

[Otherwise]

There is a risk that you may be entangled in the tractor or get injured.

## LONG-TERM STORAGE

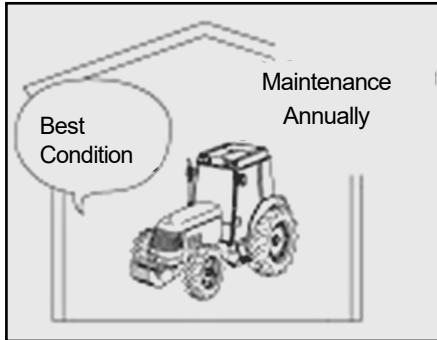

In particular, we recommend that the electrical cables and the rubber hoses, such as fuel hose, steering hoses and radiator hoses, be replaced every two years.

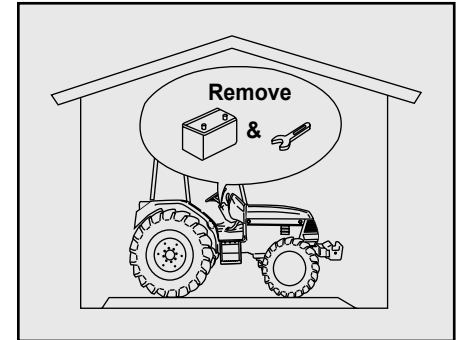

If you carry out maintenance during the off season, you can ensure optimum condition of the tractor as well as safe and comfortable working conditions during the busy season. Also, in order to secure the safety of each part of the tractor and to prevent an accident that may occur due to poor maintenance, arrange with your authorized dealer for periodic maintenance once a year.

If the tractor is not used for a long time, store it in the following manner.

1. For long storage, put the main (ignition) key switch to "OFF".
2. Select a dry and well-drained place for storage. Remove detach the weight & implement or put it down onto the ground.

3. Fill up the fuel tank. Empty space in the fuel tank will produce condensation that will produce rust formation. And lock the fuel cock to "C". (Closed)
4. Disconnect the battery completely and store it away from the tractor in a well-ventilated, dry, dark place if possible. When the battery is attached to the tractor, make sure to connect the (+) terminal first.
5. Change the engine oil and run the engine to circulate oil throughout all the engine parts for about 5 minutes.
6. Drain the coolant from the radiator. After draining the coolant, attach a tag of "No coolant, do not start" to the steering wheel. If there is anti-freeze in the cooling system, it is not necessary to drain it.
7. Check the bolts and nuts for looseness, and tighten if necessary.
8. Add oil, fluid and fuel to each part according to the maintenance chart.
9. Apply a slight coat of grease or oil onto the tractor parts where is easy to be rust such as bare metal surface.
10. Inflate the tires to a pressure a little higher than usual.
11. Place chocks behind and in front of the rear wheels.
12. Store it in a dry indoor place to avoid rain or snow and cover the body.

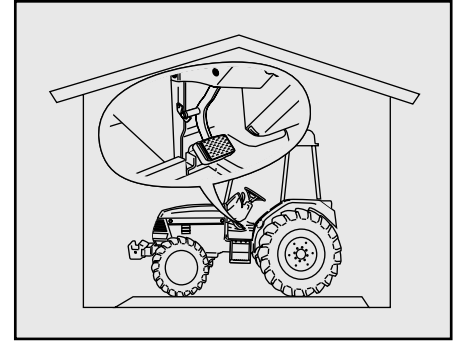

13. Keep the clutch pedal in a depressed position to avoid rust on the clutch.
14. Put all controls into the neutral position.

**⊕ IMPORTANT**

- When cleaning the tractor, be sure to stop the engine. Allow sufficient time for the engine to cool before washing.
- Cover the tractor after the muffler and engine have cooled down completely.

**⚠ WARNING**

- Carry out maintenance on a flat and safe place where the tractor will not fall or move and there is no traffic danger. Also, block the front tires to prevent moving of the tractor. Otherwise, there is a risk of accident, such as overturning of the tractor.

**⚠ WARNING**

- Carry out checking and maintenance for each part every year.
- In particular, replace the fuel hoses and the steering hoses every two years. Otherwise, there is a risk of accident or machinery breakdown due to poor maintenance.
- When carrying out checking or maintenance, make sure to stop the engine.
- Replace the covers that have been defected for checking or maintenance.
- Carry out checking or maintenance after heated parts, such as muffler, engine or transmission, have fully cooled down. Otherwise, there is a risk of getting burnt.

**⚠ CAUTION**

To avoid a personal injury,

- Never clean the tractor body while the engine is running.
- Never run the engine in an enclosed area without proper ventilation system in order to prevent poisoning by exhaust gas.
- When storing the tractor, remove the key from the switch and store it separately in order to prevent an unauthorized person from operating the tractor and being injured.



## OPERATING TRACTOR AFTER LONG-TERM STORAGE

Keep the following instructions when operating the tractor after its long-term storage.

1. Perform the inspection procedures before operation.
2. Check the tire air pressure and inflate the tires if it is low.
3. Install a fully charged battery. Check that the battery is fully charged before installing it.
4. Check the fan belt tension.
5. Check all fluid levels. (Engine oil, transmission/hydraulic oil, and engine coolant)
6. Remove grease from the exposed cylinder rod.
7. Apply grease to the lubrication points.
8. Remove the cover from the exhaust pipe.
9. Get onto the tractor and start the engine. To prolong the life and to enhance the performance of the engine, idle the engine for about 30 minutes before starting work.
10. Start the engine, release the parking brake, and check the brake condition by depressing the brake pedal. Adjust the free play of the brake pedals if necessary.
11. Check if the instrument panel and all parts operate correctly while running the engine for a few minutes.
12. Drive the tractor outside and check if it is operating properly. Park the tractor outside and idle the engine for at least 5 minutes. Stop the engine and visually inspect the tractor. Check if there is leakage.
13. Stop the engine and check for leakage. Repair any part as required.



### WARNING

- **When operating the tractor in an enclosed area, ventilate the area to release exhaust gas to the outside. Exhaust gas is colorless and not visible, but is harmful.**

## USAGE AND DISPOSAL

It is recommended to keep the following to protect the environment:

1. Overload on the machine shortens the product life and increases the harmful exhaust gas which causes air pollution due to the incomplete combustion.
2. When changing the fluid (engine oil, transmission/hydraulic oil, and engine coolant) by yourself, be careful not to spill it and dispose used oil and coolant properly according to the applicable regulations. Otherwise, it can pollute the ground and water.

# MEMO

A series of horizontal dotted lines for writing.

## 9. ENGINE EMISSION WARRANTY

ENGINE EMISSION WARRANTY .....9-2

## ENGINE EMISSION WARRANTY

### ► YOUR WARRANTY RIGHTS AND OBLIGATIONS

In accordance with 40 CFR Part 1039, TYM Co., Ltd. (TYM) is pleased to explain the emission control system warranty on your 2022 model year engine.

In the US, new engines must be designed, built and equipped to meet the stringent anti-smog standards. TYM must warrant the emission control system on your engine for the periods of time listed below provided there has been no abuse, neglect or improper maintenance of your engine. Additional conditions and responsibilities are further outlined below.

Where a warrantable condition exists, TYM will repair your engine at no cost to you including diagnosis, parts and labor.

### ► MANUFACTURER'S WARRANTY COVERAGE

TYM warrants to the original owner, and to each subsequent owner, of a new, diesel engine that the emission control system of your engine:

1. Was designed, built and equipped so as to conform at the time of sale with all applicable regulations.
2. Is free from defects in material and workmanship which will cause such engine to fail to conform with applicable regulations for the following warranty period:
  - For variable speed engines rated under 19 kW (25 HP): two (2) years or 1,500 hours of operation, whichever occurs first. In the absence of a device to measure hours of use, the engine shall be warranted for a period of two years.
  - For constant speed engines rated under 37 kW (50 HP) with peak power rated at less than 3,000 RPM: five (5) years or 3,000 hours of operation,

- Whichever occurs first. In the absence of a device to measure hours of use, the engine shall be warranted for a period of two years.
- For engines rated at or above 19 kW (25 HP): five (5) years or 3,000 hours of operation, whichever occurs first. In the absence of a device to measure hours of use, the engine shall be warranted for a period of five years.

The warranty period shall begin when the engine is placed into service.

**► OWNER'S WARRANTY RESPONSIBILITIES**

- This engine is designed to operate on diesel fuel only. Use of any other fuel may result in the engine no longer operating in compliance with EPA's applicable emissions requirements.
- The purchaser is responsible for initiating the warranty process. You must present the engine to a BAD BOY dealer as soon as a problem exists.
- The use of any non-exempted add-on or modified parts shall be grounds for disallowing a warranty claim. BAD BOY is not liable for failures of warranted parts caused by the use of a non-exempted add-on or modified part.
- The purchaser is responsible for the performance of all scheduled maintenance or repairs on this new TYM engine.

BAD BOY may deny a warranty claim if warranty claim if failure to perform maintenance results in the failure of a warranted part.

Receipts covering the performance of regular maintenance should be retained in the event of questions arise concerning maintenance.

The receipts should be transferred to each subsequent owner of the equipment with the emission warranted engines.

**► EMISSIONS WARRANTY EXCLUSIONS**

- Malfunctions in any part caused by misuse, abuse, improper adjustments, modifications, alteration, tampering, disconnection, improper or inadequate maintenance, or use of fuels not recommended for the engine as described in the Maintenance Manual.
- Damage resulting from accident, acts of nature or other events beyond the control of TYM.
- Loss of time, inconvenience, loss of use of equipment, engine or commercial loss.

**► EMISSION PARTS COVERED UNDER WARRANTY**

The following is a list of emission control parts that are covered by the Limited Emission Control System Warranty.

This warranty covers include any engine parts related to the following systems:

- Fuel Injection Pump
- Fuel Injectors
- Ignition system
- Intake Manifold
- Electronic control units (if equipped)
- Sensors (if equipped)
- Exhaust Manifold
- Positive Crankcase Ventilation system parts (including PCV Valve and Oil Filler Cap)
- Turbocharger (if equipped)
- Charge air cooling system (if equipped)
- Smoke puff limiter (if equipped)
- EGR (if equipped)
- Air-induction system (e.g., intake and exhaust manifolds).

- Aftertreatment devices, if equipped (e.g., Diesel Particulate Filter [DPF], Diesel Oxidation Catalyst [DOC]).
- Miscellaneous hoses, clamps, connectors and sealing gaskets or devices used in the above systems.

Emission-related components also include any other part whose only purpose is to reduce emissions or whose failure will increase emissions without significantly degrading engine/equipment performance.

**► CUSTOMER ASSISTANCE**

If you have any questions regarding your warranty rights and responsibilities, you should contact our official TYM US dealer.

BAD BOY TRACTORS  
102 INDUSTRIAL DR  
BATESVILLE, AR 72501  
866-622-3269

Web site : <https://www.badboycountry.com/>

# **5045 / 5055**

## **(C, CH, S, HN)**

### **OPERATOR'S MANUAL FOR BAD BOY TRACTORS**

⚠ ALL INFORMATION, ILLUSTRATIONS AND SPECIFICATIONS IN THIS MANUAL ARE BASED ON LATEST INFORMATION AVAILABLE AT THE TIME OF PUBLICATION. THE RIGHT IS RESERVED TO MAKE CHANGES AT ANY TIME WITHOUT A NOTICE.

**24.05.09**



5045

5055

**BAD**  **BOY**  
— TRACTORS —

[www.badboycountry.com](http://www.badboycountry.com)