

10' CUTTER

OWNER'S OPERATION & PARTS MANUAL

For additional information, please see us at
www.badboymowers.com

Bad Boy, Inc.
102 Industrial Drive
Batesville, Arkansas 72501

TO THE DEALER

Assembly, initial lubrication, and verification of proper installation of this product is the responsibility of the Bad Boy Cutter dealer. Be familiar with the safety rules and instructions found in this manual. Ensure all items on the Dealer's Pre-Delivery and Delivery Checklists in this manual are completed before releasing the cutter to the new owner. ***This cutter is sent from the factory without gearbox oil in the gearbox, or grease in the tail wheel.***

TO THE OWNER

Note: Anyone who operates your Bad Boy Cutter must first read this owner's manual. Although this cutter has been engineered with safety and reliability as the foremost concerns, there is no substitute for an informed and cautious operator. This manual should be viewed as a part of the equipment itself. If this manual is lost, destroyed, or otherwise rendered unreadable, obtain a duplicate immediately. A duplicate can be obtained online at www.badboymowers.com.

As with all machinery, this cutter requires periodic maintenance and should be kept free of debris buildup. Proper care will ensure many years of dependable service. Replacement parts should only be obtained from your Bad Boy Cutter dealer or through the website referenced above.

Failure to utilize approved parts can be dangerous and will void the warranty.

LEA EL INSTRUCTIVO!

Si no lee Ingles, pida ayuda a alguien que si lo lea para que le traduzca las medidas de seguridad.

Three terms are utilized throughout this manual and are present on the cutter's safety decals:

DANGER, WARNING, and CAUTION.

- DANGER:** Indicates a hazardous situation that, if not avoided will result in death or serious injury.
WARNING: Indicates a hazardous situation that, if not avoided, could result in death or serious injury.
CAUTION: Indicates a hazardous situation that, if not avoided, could result in minor or moderate injury.

In order to better draw attention to these important safety messages, the above terms are accompanied with the following pictorial:



TABLE OF CONTENTS

SPECIFICATIONS.....	4
SAFETY RULES	5
GENERAL INFORMATION	8
OPERATION	8
OWNER SERVICE.....	13
TROUBLESHOOTING	18
CUTTER ASSEMBLY AND PART LIST	19
FASTENER TORQUE CHART	22
DEALER'S CHECKLISTS.....	23
PRODUCT WARRANTY	24

SPECIFICATIONS

Category	Drag
Gear Box	Omni Gear RC 61 and T-Box
Gear Box Mount	3/8" Steel
Deck Thickness	10 GA
Skirt Thickness	1/4"
Skid Shoes	1/4" Replaceable
Tail-Wheel	4" x 15" Puncture Resistant Bushing Style
Stump Jumper	15 splined, Standard duty, Infinity Pan style
Warranty	2 year limited
Weight	2050 lbs.
Length (Including Tail-Wheel)	145"
Total Width	130"
Overall Height	21"
Deck Height	12"
Cut Range	2" – 12"
PTO Drive Shaft	Slip Clutch with CV U-Joint
Blades	31" x 1/2" x 4" (28 1/2" Working Length)
Tractor Range	60 – 120 HP
Cutting Capacity	2" Diameter
Blade Tip Speed	15,484 feet / minute
Blade Spindle	2
Tractor PTO RPM	540

SAFETY RULES

Note: (Safety instructions are important!! While these instructions may seem length or redundant, they are presented for your safety)

TRAINING

- Almost all accidents arising from the use of equipment such as this that has resulted in injury or death would have been avoided had instructions such as these been adhered to.
- If you do not understand any part of this manual, contact your dealer for assistance.
- Dangerous situations can arise quickly. Know your controls and how to stop the engine and attachment in an emergency. Fractions of a second can be extremely important.
- Do not allow anyone to operate the equipment without first requiring them to read this manual and giving proper instruction.
- Never allow children (< 16 years of age) or untrained persons to operate the equipment.

PREPARATION

- Check that all of the hardware is properly installed.
- Loose clothing can become caught in moving parts. Entanglement with the rotating PTO shaft is the #1 cause of death and injury with equipment such as this. Always wear relatively tight and belted clothing to reduce this risk.
- Wear sturdy, rough-soled work shoes and protective equipment for eyes, hair, hands, hearing, and head. Wear a respirator or filter mask where appropriate.
- Make sure the cutter is properly secured, adjusted, lubricated, and in good operating condition.
- Make sure spring-activated locking pin slides freely and is seated firmly in tractor PTO spline groove.
- Connect PTO drive-line directly to power unit PTO shaft. Never use adapter sleeves or adapter shafts. Adapters can cause drive-line failures.
- Before starting power unit, check drive-line guards for damage. Do not operate without replacing any damaged guards. Ensure the guards rotate freely on the drive-line. If they do not, repair or replace bearings before operating the cutter.
- Tractor must be equipped with Roll-Over Protective Structure (ROPS) or ROPS cab and seat belt. ALWAYS keep seat belt securely fastened. Falling off the tractor can, and does, result in death. Keep folding ROPS system in 'locked up' position at all times.
- Inspect guards before use. Replace if damaged. DO NOT OPERATE the cutter without guards in place.
- Accumulation of debris can present hazards. Remove accumulated debris from the cutter and tractor before use.
- Make sure all safety decals are installed and free from damage. Replace if damaged.
- A minimum of 20% of tractor and equipment weight must be on the tractor front wheels when attachments are in transport position. Without this weight, front tractor wheels could raise up resulting in loss of steering. The weight may be attained with front wheel weights, ballast in tires or

front tractor weights. Weigh the tractor and equipment, do not estimate.

-
- Inspect and clear the area of stones, branches, or other hard objects that might be thrown, causing injury or damage.

OPERATION

- Do not allow bystanders in the area when operating, attaching, removing, assembling, or servicing the cutter.
- This machine is equipped with front and rear guards. DO NOT operate the machine without the guards in place.
- Never direct discharge toward people, animals, or property.
- Do not operate or transport equipment while under the influence of alcohol or drugs.
- Operate only in daylight or good artificial light.
- Keep hands, feet, hair, and clothing away from equipment while engine is running. Stay clear of all moving parts.
- Always comply with all state and local lighting and marking requirements.
- **NEVER ALLOW RIDERS ON POWER UNIT OR CUTTER!**
- Always sit in the tractor seat when operating controls or starting engine. Securely fasten seat belt, place the transmission in neutral, engage the brake, and ensure all other controls are disengaged before starting the tractor engine.
- Operate the tractor's PTO at 540 RPM. Do not exceed 540 RPM.
- Do not operate the PTO during transport.
- Look down and to the rear and make sure area is clear of people, animals, property, or foreign objects before operating in reverse. Children often do not understand the severity of the potential danger. A major portion of mower/cutter accidents involve children being run over during reverse operation of the mower/cutter.
- Do not operate or transport on steep slopes.
- Do not stop, start, or change directions suddenly on slopes.
- Use extreme care and reduce ground speed on slopes and rough terrain.
- Watch for hidden hazards on the terrain during operation.
- Stop the tractor unit and the equipment immediately upon striking an obstruction. Turn the engine off and remove the key, inspect, and repair any damage before operation resumes.
- Leak down or failure of the mechanical or hydraulic system can cause equipment to drop.
- Make certain all movement of equipment components has stopped before exiting the tractor.

MAINTENANCE

- Before performing any service or maintenance, disconnect the drive-line from the tractor's PTO.
- Before working underneath the equipment, disconnect the drive-line, raise the cutter, and block the cutter securely. Hydraulic system leaking down and failure of mechanical or hydraulic system can cause equipment to drop.

- Do not allow bystanders in the area when operating, attaching, removing, assembling, or servicing the equipment.
- Keep all persons away from the operator control area while performing adjustments, service, or maintenance.
- Do not modify or alter (or permit anyone else to modify or alter) the equipment or any of its components in any way.
- Always wear relatively tight and belted clothing to avoid getting caught in moving parts. Wear sturdy, rough-soled work shoes and protective equipment for eyes, hair, hands, hearing, and head.
- Make certain all movement of the equipment components has stopped before approaching for service.
- Frequently check the blades. They should be sharp, free of nicks and cracks, and securely fastened.
- Do not handle the blades with bare hands. Always use gloves. Careless or improper handling may result in serious injury.
- Your dealer can supply genuine replacement blades. Substitute blades may not meet original equipment specifications and may be dangerous.
- Check that the cotter pin and roll pin (gearbox output shaft and through the top of the tail-wheel shaft) are installed securely to ensure equipment is in a safe condition before placing the cutter into service.

STORAGE

- Keep children and bystanders away from storage area.
- Disconnect the cutter drive-shaft and secure it up and off the ground. Raise the cutter using the hydraulics. Place blocks under the cutter side skirts. Lower the cutter onto blocks. Disconnect the Hydraulic line. Disconnect the cutter from the tractor pull hitch and carefully drive the tractor away from the cutter.

CHILDREN

Extremely tragic accidents can, and do, occur if the operator is not continually alert to the presence of children. Children are often attracted to machinery and the mowing activity. NEVER assume that children will remain where you last saw them.

- Keep children out of the mowing area and under the watchful care of responsible adult other than the operator.
- As this machine is capable of, and used for, cutting relatively tall grass, always be vigilant in monitoring the field ahead. Accidents in which children were obscured by tall grass and not easily seen by the operator have occurred with equipment of this type. The results are often life shattering for all involved. Be constantly aware during operation!
- Immediately turn the equipment off if a child enters the area.
- Never allow children to operate the equipment (<16 years of age).
- Use extra care when approaching blind corners, shrubs, trees, or other objects that may block your view of a child.

GENERAL INFORMATION

WARNING

The purpose of this manual is to assist you in operating and maintaining your cutter. Read it carefully. It furnishes information and instructions that will help you achieve years of dependable performance. These instructions are the product of extensive field experience, engineering data, accident reports, and statistical data. Although some information may be general in nature due to unknown and varying operating conditions, through experience and adherence to these instructions, you should be able to develop sound operating procedures suitable to your particular situation.

The illustrations and data used in this manual were current at the time of printing, but due to possible running changes, your machine may vary slightly in detail. Bad Boy Cutters reserves the right to redesign and change the machines as necessary without notification.

Throughout this manual, references are made to right and left sides of the equipment. These directions are determined by standing behind the equipment. Also, blades rotate to the front center of the cutter. The blade directions are as viewed from the top of the cutter.

OPERATION

The operator is responsible for the safe operation of the cutter. The operator must be properly trained. Operators should be familiar with the cutter, the tractor utilized, and all safety practices before starting operation.

This standard-duty cutter is designed for grass, weeds, and small brush. Recommended mowing speed for most conditions is between 2-5 mph.

DANGER

This machine is equipped with front and rear guards. DO NOT operate the machine without the guards in place.

Dealer Assembly Instructions

1. Attach the Front Hitch Assembly to the cutter. Align the corresponding holes and insert the provided Cat 3 pins.
2. Attach the Tail Wheels to the Tail Wheel Pivot. Slide the brackets over the tube at the desired wheel width and use the provided 5/8-11x 5" bolts and locking nuts to secure them to the pivot tube.
3. Connect the Leveling Rods to the Front Hitch Assembly and the Tail Wheel Pivot (to level the cutter, the hydraulics will need to be connected to the tractor. See item #4 on the next page).
4. Attach the hydraulic hose to the hydraulic cylinder.
5. Attach the Series 6 10' PTO Shaft to the center "T" box.

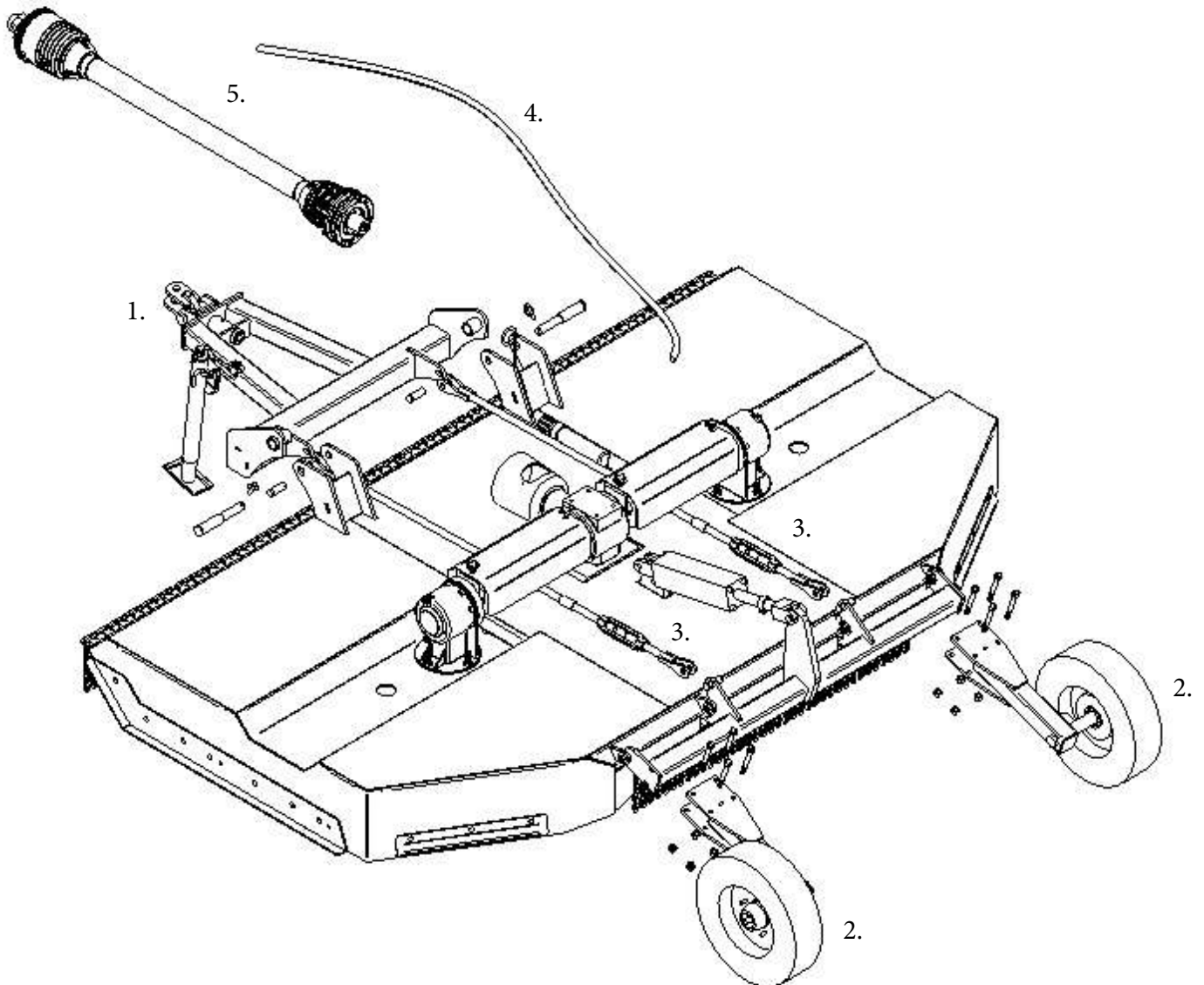

ATTACH THE CUTTER TO THE TRACTOR

CAUTION

- Make sure the drive-line will not bottom out at the shortest length and that it has at least 1/3 overlap at its longest length.

1. Attach the tongue to the Tractor.
2. Attach the PTO. Ensure that the Driveline is the proper length (refer to page 10 for instructions to shorten the driveline).
3. Attach the hydraulic line.
4. On level ground, level the mowing deck by adjusting the leveling rod turnbuckles. This will help to ensure an even cut.

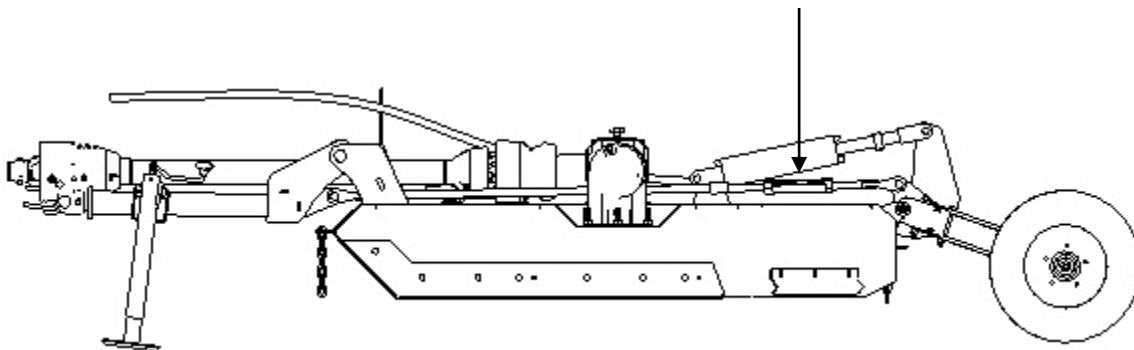

DRIVELINE INSTALLATION (TRACTOR PTO)

WARNING

Make sure spring-activated locking pin slides freely and is seated firmly into the tractor PTO spline groove.

INSTALLATION

Push the spring-activated locking pin and at the same time, push the driveline onto tractor PTO shaft until the locking pin is able to engage the shaft.

REMOVAL

Hold the driveline securely in position, push the spring-activated locking pin and slide the driveline off of the tractor PTO shaft.

DRIVELINE ADJUSTMENT

Attach the cutter to the tractor drawbar. Connect the hydraulic cylinder hose. Do not attach driveline. Raise and lower the cutter to determine maximum and minimum distance between the tractor PTO shaft and the gearbox input shaft. If the distance is too large, the driveline will be too short for proper engagement; this can damage the driveline during operation. If the distance is too small, the driveline may bottom out during operation and damage the cutter or tractor. If the driveline is too short, please call your Bad Boy Cutter dealer for a longer driveline. If the driveline is too long, follow the instructions below for shortening the driveline.

SHORTEN DRIVELINE

1. Move the cutter up and down to find the shortest possible distance between tractor PTO shaft and gearbox input shaft.
2. Separate the driveline into its two halves and connect them to the tractor PTO and gearbox.
3. Place the driveline halves parallel to one another in order to find the necessary driveline length reduction.
4. Measure from the end of the shield (tractor half) to the base of the bell shield (cutter half; see figure below). This is measurement 'A' in the figure. Add 1-9/16" to measurement 'A'.
5. Using a hacksaw, cut the overall length from the end of the plastic, cylindrical driveline shield (tractor half) as indicated in the figure.
6. Place this cutoff portion of the shield against the metal shaft (of the same driveline half) and use this as a guide. Mark and cut the metal shaft.
7. Repeat step 6 for the other half of the drive.
8. File and clean the cut ends of both drive halves.



Do not use the tractor if proper driveline engagement cannot be obtained through these methods. Connect the driveline to the tractor PTO shaft, making sure the spring-activated locking pin slides freely and locks the driveline to the PTO shaft.

DRIVELINE INTERFERENCE CHECK

1. Check for clearance between the drive-line and cutter deck.

OPERATING TECHNIQUE

- Operating power for the cutter is provided by the tractor's PTO. Operate the PTO at 540 RPM (never exceed). Know how to stop the tractor and cutter quickly and safely in the event of an emergency.
- Engage the PTO at a low engine RPM. Engagement of the PTO at high engine RPM places the driveshaft and gearbox under extreme stress. After the PTO is engaged, raise the PTO speed to 540 RPM. Maintain this PTO speed throughout the cutting operation.
- Gearbox protection is provided by way of a slip-clutch. This allows the drive-line to 'slip' under excessive torsion loads. It is in this manner that the gearbox is isolated from potentially damaging shocks. Under abnormal torque loads, this model also provides protection to the drive-line itself. Slip-clutches require service to keep them fully functional. A neglected slip-clutch is akin to having no protection at all as they can lose their ability to slip.
- Move slowly into material. Adjust the tractor ground speed to provide a clean cut without lugging the tractor engine. Proper ground speed will depend on the terrain and the material's height, type, density, and moisture content. The operator will be able to determine appropriate ground speeds for different conditions. Normal ground speed ranges from between 2 and 5 mph.
- Under certain conditions, the tractor tires may push the grass down. This can result in an uneven cut. When this occurs, reduce your ground speed, but maintain the PTO at 540 RPM. Lowering your travel speed will allow the grass more time to rebound.

PRE-OPERATION CHECKLIST

OWNER/OPERATORS RESPONSIBILITY!

- Review and follow all safety rules ([pages 6-8]) and machine safety decals.
- Ensure the equipment is properly and securely attached to the tractor.
- Make sure driveline spring-operated locking pin slides freely and is seated firmly in tractor PTO spline groove.
- Lubricate all of the grease fitting locations. Make sure the PTO shaft slip joints are lubricated.
- Check to be sure that the gear lube runs out of the small check plug on the side of the gearbox.
- Check that all of the hardware is properly installed and secured.
- Check that the blades are sharp, secure, free of cracks, and that the cutting edges are positioned to lead in the relative direction (as viewed from the top of the unit).
- If using shields or guards, check that they are properly installed and in good condition. Replace if damaged.
- Check cutting height, front-to-rear attitude, and top link adjustment.
- Place tractor PTO and transmission in neutral before starting engine.
- Inspect area to be cut and remove stones, branches, or other hard objects that may be thrown and cause injury or damage.

STORAGE



- Disconnect the cutter driveshaft and secure it off of the ground. Raise the cutter to the desired height. Place blocks under the cutter skirt. Slowly lower the cutter onto the blocks.
- Disconnect the hydraulic line.
- Disconnect the front hitch section from the tractor and carefully drive the tractor away from the cutter.
- Before leaving the area, check to ensure the cutter is stable.
- Keep children and bystanders away from the storage area.

OWNER SERVICE

The information in this section is written for operators who possess basic mechanical skills. If you need help, your dealer has trained service technicians available. For your protection, read and follow the safety information in this manual.

WARNING

- **Keep all persons away from the operator controls while performing adjustments, service, or maintenance.**

CAUTION

- If you do not understand any part of this manual and need assistance, contact your dealer.
- Always wear relatively tight and belted clothing to avoid getting caught in moving parts. Wear sturdy, rough-soled work shoes and protective equipment for eyes, hair, hands, hearing and head.

BLOCKING METHOD

WARNING

- **Before performing any service or maintenance, disconnect the driveline from the tractor PTO.**
- **Never go underneath equipment (lowered to the ground or raised) unless it is properly blocked and secured. Never place any body part underneath equipment or between movable parts even when the engine has been turned off. Hydraulic system leak down, hydraulic system failures, mechanical failures, or movement of control levers can cause equipment to drop or rotate unexpectedly and cause severe injury or death. Follow the Operator's Manual instructions for working underneath and blocking requirements or have work done by a qualified dealer.**

To minimize the potential hazards of working underneath the cutter, follow these procedures:

1. Jack stands (4) with a load rating of at least 1000 lbs. are the only approved blocking device for this cutter. Install a minimum of four jack stands, one under each corner of the cutter before working underneath the unit. Do not position the jack stands under wheels, axles, or wheel supports. Components can rotate and cause the cutter to fall.
2. Consider (and check) the overall stability of the blocked unit before working underneath. The working surface must be level and solid to properly support the jack stands while they are supporting the cutter. Make sure the cutter is approximately level.

3. With full cutter weight lowered onto the jack stands, test the blocking stability carefully, but vigorously, to ensure its stability.
4. If the cutter is attached to the tractor when blocking, set the brakes, remove the key, and block the cutter before working underneath. Also, securely chock the rear tractor wheels (both in front and behind).

LUBRICATION

1. Do not allow excess grease to collect on or around parts, particularly when operating in sandy areas.
2. See the figures below for lubrication points and frequency of lubrication based on normal operating conditions. Severe or unusual conditions may require more frequent lubrication.
3. Use a lithium grease of #2 consistency with a MOLY (molybdenum disulfide) additive for all locations unless otherwise noted. Be sure to clean the fittings thoroughly before attaching the grease gun. One good pump from most guns is sufficient when the lubrication schedule is followed.
4. Equipment is shipped without gear oil in the gearbox. Remove the check plug. Fill the gearbox until it starts to run out of the check plug; 75W-90 is recommended for ambient temperatures of -5F to 60F, 85W-140 is recommended for ambient temperatures of 40 F to 120 F. The oil level will be at the same level as the horizontal input shaft when filled properly. The check plug is designed to allow for oil level checks. If oil runs out of the hole when the plug is removed, the oil level is sufficient.

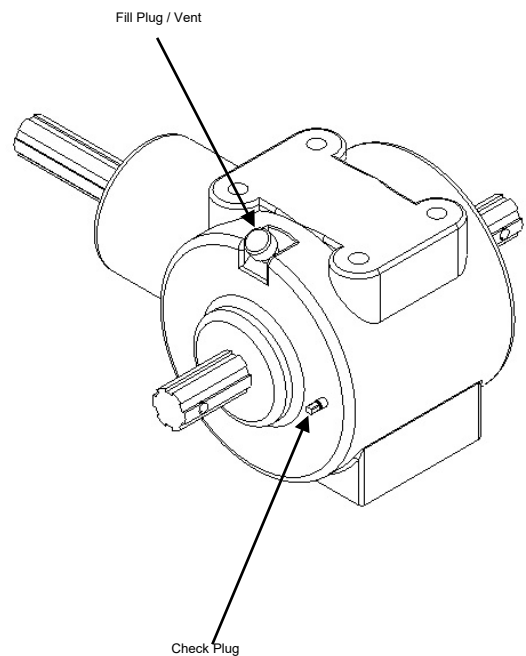
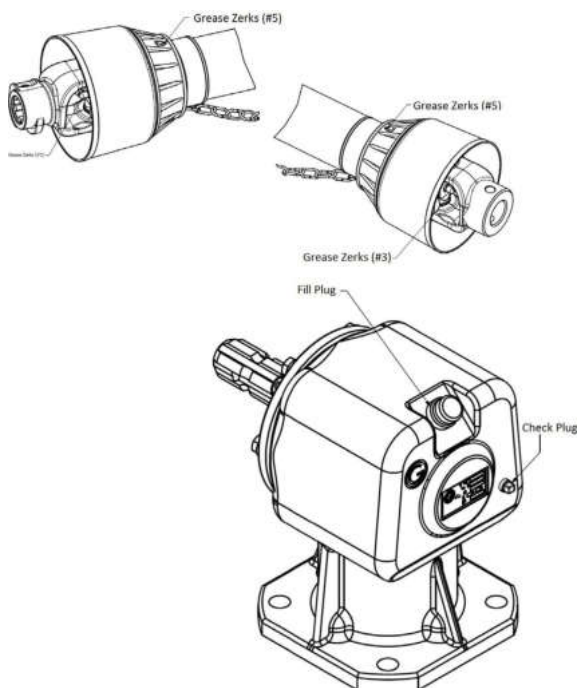

LUBRICATION POINTS

1. PTO shaft: front and rear U-joints 8 hours
2. PTO shaft: slip joint (apply grease to inner shaft)8 hours
3. PTO shaft: plastic shield bearings8 hours
4. Gearboxes (check the oil))Daily

BLADE

SERVICING

Blade Removal

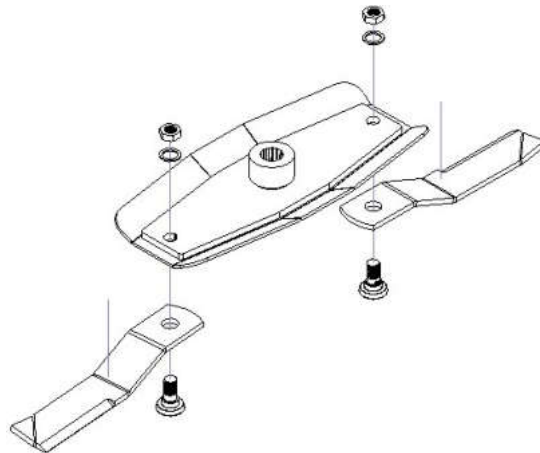

- If the blade bolt is seized in the stump jumper's crossbar and extreme force will be needed to remove it, support crossbar from below to prevent gearbox damage.

1. Disconnect the driveline from the tractor's PTO.
2. Raise the cutter and block securely.
3. Align the crossbar of the stump jumper with blade access hole in the cutter frame. Remove the blade's bolt, nut, and lock washer. Carefully drive the bolt out of the crossbar.
4. Rotate and repeat for the second set of blades.

Blade Installation



- Your dealer can supply genuine replacement blades. Substitute blades may not meet original equipment specifications and may be dangerous.
- Blade rotation is toward the center of the when looking down on the cutter. Be sure to install the blade cutting edge to lead in rotation.
- Always replace or sharpen all of the blades at the same time. Failure to do this could result in an imbalance which can cause the cutter to vibrate violently.

-
1. Inspect the blade bolts for nicks or gouges. If damage is found, replace the damaged blade bolt(s).
 2. Insert the blade bolt through the blade. The blade should swivel on the blade bolt; if it doesn't, determine the cause and correct it.
 3. Align the crossbar with the blade access hole in the cutter frame. Apply a liberal coating of an anti-seize product to the blade bolt and crossbar hole. Make sure the blade offset is away from the cutter. Push the blade bolt through the crossbar.
 4. Insert the lock washer and nut through blade access hole in the cutter deck. Install it on blade bolt and tighten to 450 ft-lbs. using a 1-11/16"6"socket.

Blade Sharpening

- Closely inspect the blades for cracks or nicks. If damage is found, replace blades in pairs.
 - When sharpening the blades, grind the same amount on each blade to maintain balance. Replace blades in pairs. Unbalanced blades will cause excessive vibration, which can damage gearbox bearings.
1. Sharpen both blades at the same time to maintain balance. Follow original sharpening pattern.
 2. Do not sharpen blade to a razor edge: leave at least a 1/16" blunt edge.
 3. Do not sharpen the back side of the blades.

SLIP-CLUTCH ADJUSTMENT

The slip-clutch (if equipped) is designed to slip so that the gearbox and the driveline are protected if the cutter blades strike an obstruction.

A new slip clutch or one that has been in storage over the winter may seize, rendering the shaft and gearbox completely unprotected. Before operating the cutter, make sure it will slip by performing the following operation:

1. Turn the tractor off and remove the key.
2. Loosen the nuts on the springs until the springs can rotate freely, yet remain secure on the bolts.
3. Make in-line marks on the outer plates of the slip-clutch.
4. Securely attach the cutter to the tractor and start the tractor.
5. Engage the PTO for several seconds then quickly disengage it.
6. Turn the tractor off and remove the key.
7. The friction plates should have "slipped." If the marks made previously are no longer in-line with each other, this is the case.
8. If the clutch does not slip, check assembly for oil, grease, and debris.
9. Reassemble the clutch and tighten the bolts no more than 1/8 of a turn at a time until the desired setting of 1.15" spring length is reached.
10. If excessive slippage continues, check the lining plates for excessive wear. The slip plates are 1/8" thick when new. They should be replaced after 1/32" of wear to ensure proper operation.

SHIELDING REPAIR



- This machine is equipped with front and rearguards.
- **DO NOT** operate the machine without the guards in place.

Chain Shielding

Inspect the chain shielding after each day of operation and replace any broken or missing chains as required.

Driveline Shielding

Inspect for damaged covers and/or loose fasteners.

CLEANING

After Each Use

- Remove large debris (clumps of dirt, grass, crop residue, etc.) from the machine.
- Inspect the machine and replace any worn or damaged parts.
- Replace any missing, damaged, or otherwise unreadable safety decals.

Periodically or Before Extended Storage

- Clean large debris (clumps of dirt, grass, crop residue, etc.) from the machine.
- Remove the remainder using a low-pressure waterspray.
 1. Take extra care when spraying near safety decals. The water spray could penetrate under the decal and peel it off.
 2. Be careful when spraying near any paint damage. The spray could remove more paint.
- Inspect the cutter and replace any worn or damaged parts. After an extended period of non-use, any damage to the cutter may be overlooked, or forgotten, when the machine is again put into service.
- Sand down scratches and the edges of areas of missing paint and coat with Bad Boy touch-up paint.
- Replace any missing, damaged, or otherwise unreadable decals.

TROUBLESHOOTING

PROBLEM	POSSIBLE CAUSE	SOLUTION
Streaking conditions in path.	<p>Conditions too wet for mowing.</p> <p>Blades unable to cut grass pressed flat by tractor tires.</p> <p>Dull Blades</p>	<p>Allow grass to dry before mowing.</p> <p>Slow ground speed of tractor but keep PTO running at 540 RPM.</p> <p>Sharpen or replace blades.</p>
Material discharges from the cutter unevenly; material bunches along path.	<p>Material too high and dense.</p> <p>Grass is wet.</p> <p>Rear of cutter too low, trapping material under cutter.</p>	<p>Reduce ground speed (maintaining 540 RPM tractor PTO) or make two passes. Raise the cutter for the first pass; then lower the cutter to desired height and cut perpendicular to the first passes.</p> <p>Allow grass to dry before mowing.</p> <p>Adjust cutter height and attitude.</p>
Cutter will not cut all the time (Slip-clutch model).	Slip-clutch excessively slipping.	Adjust slip-clutch according to instructions under 'SLIP-CLUTCH ADJUSTMENT' section of this manual.



PARTS SECTION:

Parts List				
ITEM	QTY	PART NUMBER	DESCRIPTION	REV
1	1	350-0027-00	Agri Supply 2500psi 12" Stroke #87081	
2	2	301-0041-00	10ft Rotary Cutter Skid Plate Weldment	
3	84	347-0005-00	10' cutter link chain_front_7 Link	
4	1	364-0010-00	10' Rotary Cutter front cable	
5	2	340-0016-00	Cat3_2 Pin	
6	4	332-0005-00	10ft Rotary cutter pivot bolt bushing	
7	14	018-5044-00	3/8" x 1" Carriage Bolt	
8	22	019-8044-00	5/16" Flat Washer	
9	1	367-0001-00	Document Holder	
10	2	018-2007-00	5/16" x 1" Bolt	
11	7	013-5041-00_MIR	3/8 Nylock Nut	
12	2	339-0065-00	6ft side armor	A
13	1	364-0011-00	10' Rotary Cutter Rear cable	
14	8	319-0002-00	3/4 F/W USS (2" OD) ZC	
15	12	013-0014-00	3/4" CenterLock Nut GrC (Fine)	
16	2	340-0014-00	7/16"x2x Lynch pin	ANY
17	2	013-9002-00	5/16" Flange Nut	
18	12	318-0021-00	3/4-16 x 2 5/8 grade 8 hex bolt	
19	37	347-0006-00	10' cutter link chain_rear_6 Link	
20	1	350-0026-00	168" Hydraulic Hose	
21	1	350-0028-00	10ft Rotary Cutter Hydraulic Stop Kit	

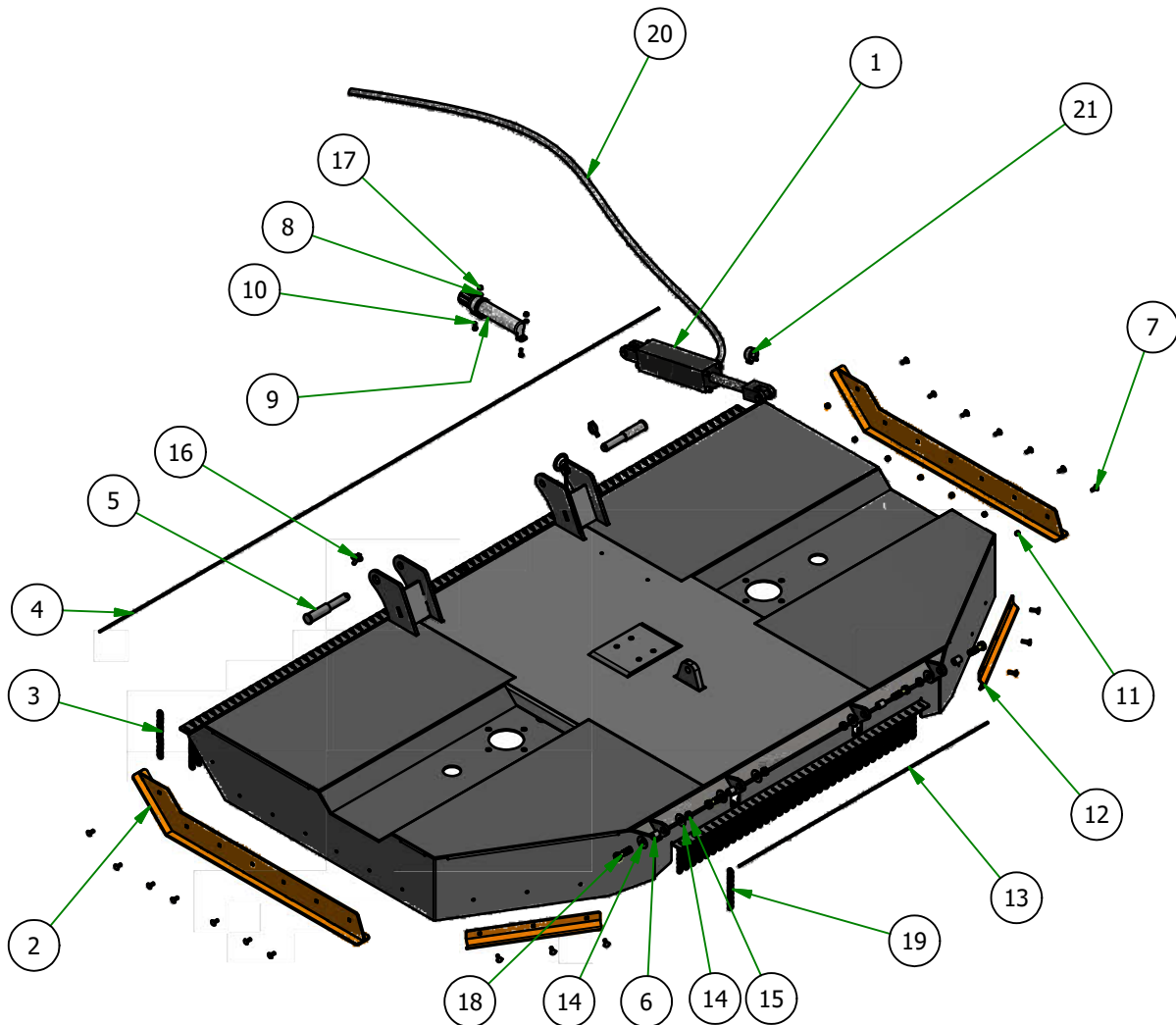



PARTS SECTION: DRIVELINE

Parts List			
ITEM	QTY	PART NUMBER	DESCRIPTION
1	22	019-8044-00	5/16" Flat Washer
2	4	045-6043-00	5/16" Knob
3	2	339-0098-00	10ft Rotary Cutter Cross Shaft Guard
4	15	018-8063-00	5/16" x 3/4" Hex Bolt
5	4	019-8051-00	5/16" Lock Washer
6	12	013-0014-00	3/4" CenterLock Nut GrC (Fine)
7	12	318-0021-00	3/4-16 x 2 5/8 grade 8 hex bolt
8	8	313-0014-00	3/4-16 Jam Hex Nut Grade 8
9	1	314-0007-00	10ft PTO Guard
10	1	350-0025-00	Series 6 10ft PTO Shaft
11	4	019-4807-00	5/8" Lock Washer
12	4	018-6020-00	5/8-18 X 1-1/2 HEX CAP SCREW (GR.8) ZINC YELLOW
13	2	338-0016-00	CCW RH 10' Blade
14	2	338-0015-00	CW LH 10' Blade
15	1	350-0024-00	Grizzly 61T 1.21 T-Box
16	2	337-0003-00	1 - 14 Castle Nut
17	2	337-0002-00	Cotter pin
18	2		Grizzly RC-61 Gearbox
19	2	350-0023-00	10' Rotary Cutter Cross Shaft
20	4	318-0001-01	Blade Bolt
21	2	337-0008-00	10ft Rotary Cutter Blade Carrier Weldment
22	4	318-0001-02	Blade Bolt Lock Washer
23	4	318-0001-03	Blade Bolt Nut

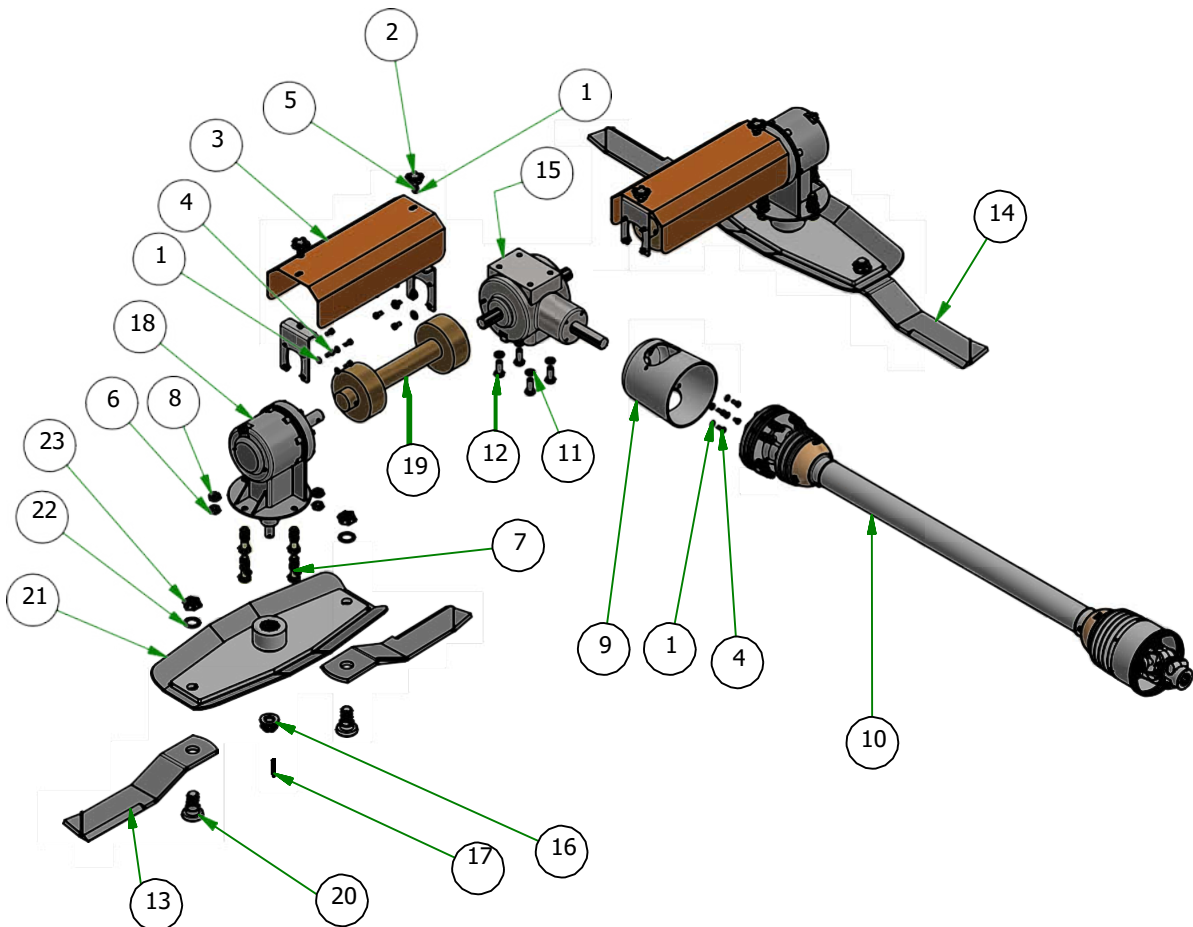



PARTS SECTION: HITCH ASSEMBLY

Parts List				
ITEM	QTY	PART NUMBER	DESCRIPTION	REV
1	2	340-0016-00	Cat3_2 Pin	
2	2	340-0014-00	7/16"x2x Lynch pin	ANY
3	1	360-5050-00	10ft Rotary Cutter Pull Hitch Weldment	
4	1	339-0093-00	10ft Rotary Cutter Yoke Weldment	
5	1	018-0026-00	1-14 x 5.5 Hex Bolt Grade 8 Zinc Yellow	
6	1	313-0022-00	1"-14 Grade 8 hex nut	
7	1	319-0009-00	1" split washer yellow zinc	
8	1	338-0017-00	10ft Rotary Cutter Swivel Jack	

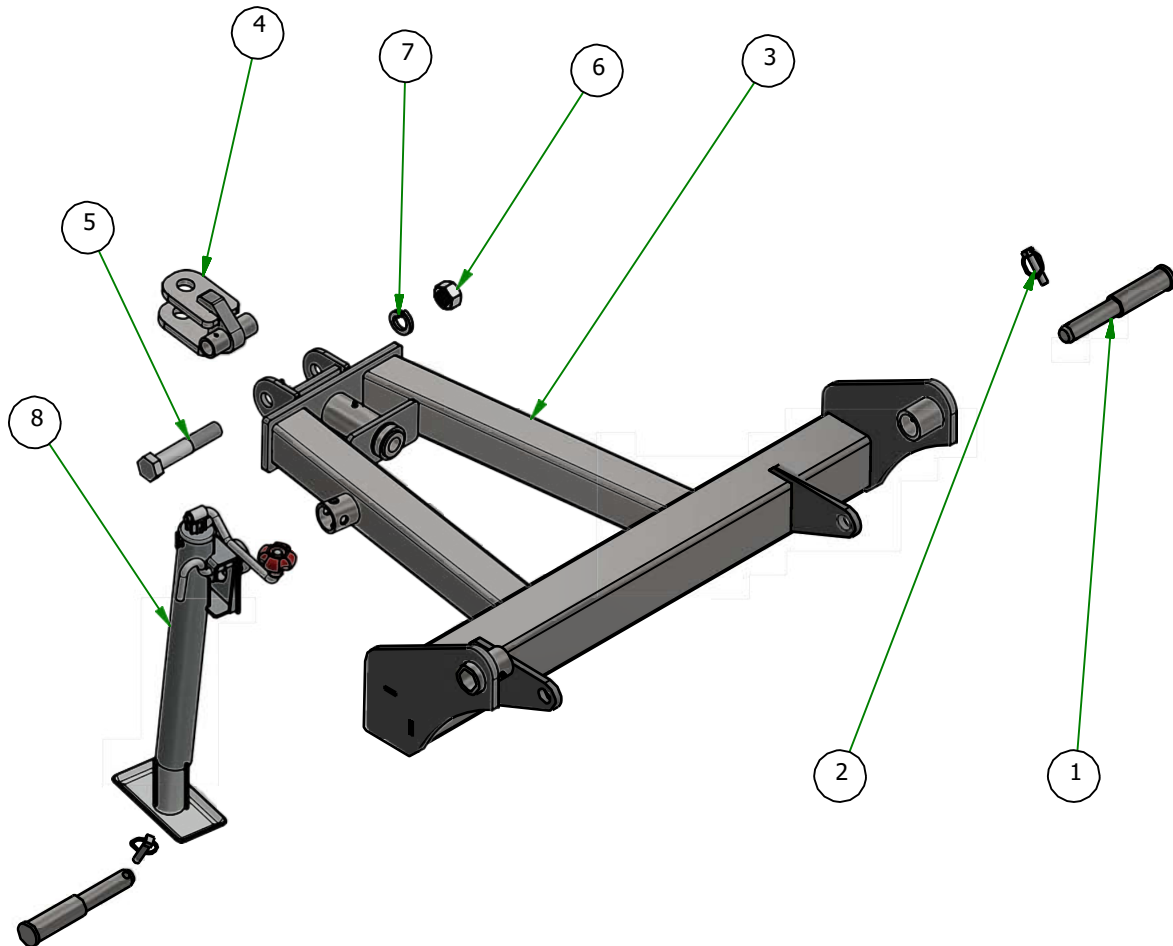



PARTS SECTION: Tail Wheel Section

Parts List				
ITEM	QTY	PART NUMBER	DESCRIPTION	REV
1	4	332-0005-00	10ft Rotary cutter pivot bolt bushing	
2	4	313-0020-00	1"-8 Hex Nut LH GR5	
3	8	319-0002-00	3/4 F/W USS (2" OD) ZC	
4	12	013-0014-00	3/4" CenterLock Nut GrC (Fine)	
5	12	318-0021-00	3/4-16 x 2 5/8 grade 8 hex bolt	
6	4	044-2009-00	10ft Rotary Cutter Leveling Rod Pin	
7	2	350-4013-00	10ft Rotary Cutter Tailwheel Axle Weldment	
8	1	350-4016-00	10ft Rotary Cutter Tailwheel Pivot Weldment	
9	8	018-6015-00	5/8-11 x 5" Hex Head Bolt	
10	8	013-7021-00	5/8 Std NC Nylock Nut	
11	2	322-0010-00	10ft Rotary Cutter 2500lb Capacity Hub	
12	2	322-0011-00	10ft Rotary Cutter 6x 9 Tailwheel	
13	2	tumbuckle-001		
14	2	12inch leveling rod weldment		
15	2	61inch leveling rod weldment		

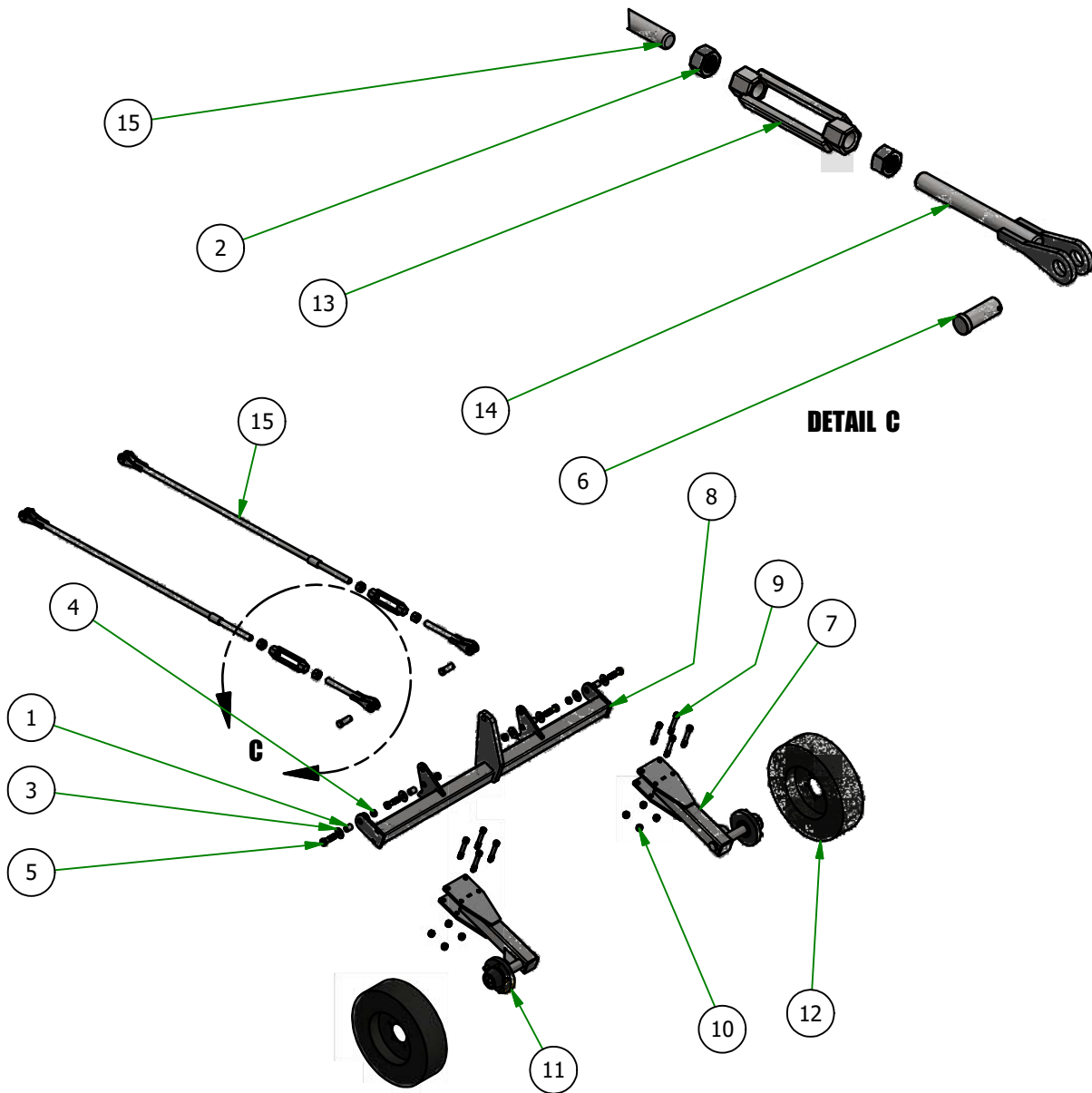

FASTENER TORQUE CHART

NOTICE: Torque values given in the above text assume an un-lubricated fastener. If using a lubricated fastener, reduce the torque (given in the previous text) by 25%.

Fastener	Torque (Lubricated/Unlubricated)
5/8" x 2-1/2" Hex Bolt	56 ft-lbs. / 75 ft-lbs.
1/2" x 1-1/4" Hex Bolt	52 ft-lbs. / 70 ft-lbs.
5/8" x 66" Hex Bolt	90 ft-lbs. / 120 ft-lbs.
5/8" x 1-3/4" Hex Bolt	150 ft-lbs. / 200 ft-lbs.
1-1/8" Blade Bolt	337 ft-lbs. / 450 ft-lbs.

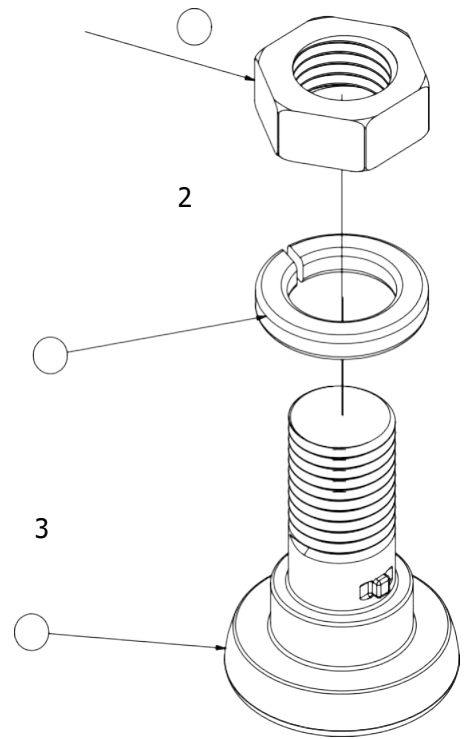
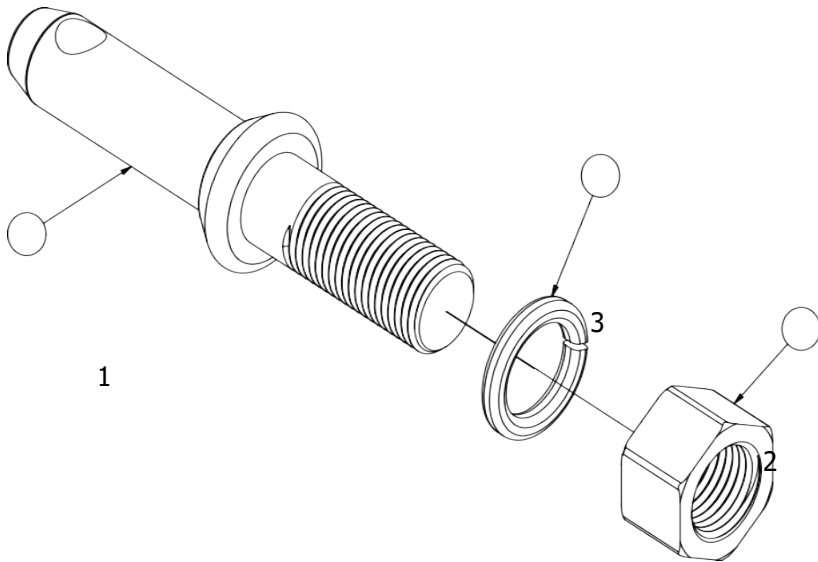

Parts List			
ITEM	QTY	PART NUMBER	DESCRIPTION
1	1	340-0002-00	Lift Pin
2	1	340-0003-00	Lift Pin Nut
3	1	340-0004-00	Lift Pin Washer

Parts List			
ITEM	QTY	PART NUMBER	DESCRIPTION
1	1	318-0001-01	Blade Bolt
2	1	318-0001-03	Blade Bolt Nut
3	1	318-0001-02	Blade Bolt Lock Washer

DEALER'S CHECKLISTS

PRE-DELIVERY CHECK LIST

It is the dealer's responsibility to fully assemble and inspect the cutter before the customer takes delivery of the unit. The following check list is provided as a memory aid to ensure all points are inspected. Check off the items below as they are completed.

- Check the torque of all bolts to be sure they meet the values given in the Fastener Torque
- Chart(pg.22) Check that the cotter pin is properly secured.
- Check the PTO shaft for proper installation.
- Check that the gearboxes are properly filled with gear oil and that no seals are leaking.

- Grease all lubrication points as shown in Lubrication (pgs. 14-15).
- Check that the blades have been properly installed. The cutting edge should lead toward the front center of the cutter as viewed from above.

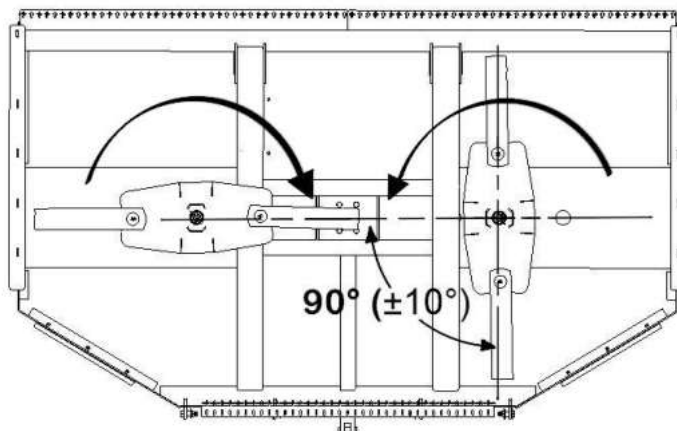

DELIVERY CHECKLIST

- Explain the importance of periodic inspections and lubrication to the customer.
- Present the Owner's Manual to the customer and request that the customer and all other users read the material before operation.
- Explain the importance of the safety rules.
- Explain the importance of the front ballasts. This unit weighs 650 pounds; the customer needs to weigh the
- tractor and equipment to ensure at least 20% of the total weight is on the tractor's front wheels.
- Explain that if the unit is transported on or along a roadway, safety devices (such as reflector decals) should be utilized in order to alert motorists of the equipment's presence.

- **IMPORTANT-** The gearbox was not filled with gear oil at the factory. It must be filled before the cutter can be placed into service (see Lubrication, pg. 14). Failure to fill the gearbox with the proper quantity of gear oil will result in damage to the gearbox.

WARRANTY

OWNER/OPERATOR'S RESPONSIBILITY

It is the owner and/or operator's responsibility to read the owner's manual before use. Failure to read the owner's manual is considered a misuse of this equipment.

It is the owner and/or operator's responsibility to inspect the product and to have any part(s) repaired or replaced before continued operation. Failure to do so could cause damage, excessive wear to other parts, or jeopardize operator safety.

LIMITED WARRANTY

Bad Boy Cutters warrants to the original purchaser of any new Bad Boy Cutter(s) that the equipment be free from defects in material and workmanship for a period of two (2) year from date of retail sale. (5 year on Gearbox.)

At Bad Boy Cutters request, the customer will make the defective part available for inspection by Bad Boy Cutters and/or return the defective part to Bad Boy Implements. Transportation charges prepaid.

WHAT THIS WARRANTY DOES NOT COVER: This warranty does not cover defects caused by depreciation or damage caused by wear, accidents, improper maintenance, improper use or abuse of the product, alterations, or failure to follow the instructions contained in the Owner's Manual for operation and maintenance.

Normal maintenance service and consumable items such as gearbox lubricant, blades, tire, or normal deterioration of exterior finish due to use or exposure.

Bad Boy Implements will not be responsible for the pickup and delivery of a machine for warranty purposes or inspection.

WARRANTY LIMITATION:

THERE IS NO OTHER EXPRESSED WARRANTY. ANY WARRANTY THAT MAY BE IMPLIED FROM THIS PURCHASE INCLUDING MERCHANTABILITY AND FITNESS FOR A PARTICULAR PURPOSE IS HEREBY LIMITED TO THE DURATION OF THIS WARRANTY AND TO THE EXTENT PERMITTED BY LAW ANY AND ALL IMPLIED WARRANTIES ARE EXCLUDED. Some states do not allow limitations on how long an implied warranty lasts, so the above limitations may not apply to you.

BAD BOY CUTTERS WILL NOT BE LIABLE FOR ANY INCIDENTAL, CONSEQUENTIAL, OR SPECIAL DAMAGES AND/OR EXPENSES IN CONNECTION WITH THE PURCHASE OR USE OF THE CUTTER.

Some states do not allow the exclusion or limitation of incidental or consequential damages, so the above limitation(s) or exclusion(s) may not apply to you.

HOW TO OBTAIN SERVICE UNDER THIS WARRANTY:

Warranty service can be arranged by contacting the dealer where you purchased the Implement or by contacting Bad Boy Implements at warranty@badboycutters.com.

Proof of the date of purchase may be required to verify warranty coverage.

B. Warranty claims will not be reviewed or paid unless the warranty registration is received by Bad Boy Cutters within 30 days of the retail purchase date.

Record the model number, serial number and date purchased. This information will be helpful obtaining parts or service if required.

SERIAL NUMBER _____

DATE OF RETAIL SALE _____

PLACE OF PURCHASE _____



www.badboymowers.com

Bad Boy, Inc.

102 Industrial Drive

Batesville, Arkansas 72501