



# MZ SERIES

## ZERO-TURN MOWER

## OWNER'S, SERVICE & PARTS MANUAL

For additional information, please see us at  
[www.badboymowers.com](http://www.badboymowers.com)

Bad Boy, Inc.  
102 Industrial Drive  
Batesville, Arkansas 72501

---

# TABLE OF CONTENTS

Basic Information .....	<b>Section 1</b>	Page 4
Bad Boy Safety Guidelines .....	<b>Section 2</b>	Page 5
Operation .....	<b>Section 3</b>	Page 9
Maintenance.....	<b>Section 4</b>	Page 10
Storage and Transportation .....	<b>Section 5</b>	Page 10
Troubleshooting and FAQ .....	<b>Section 6</b>	Page 12
Controls .....	<b>Section 7</b>	Page 13
Moving In-operable Mower .....	<b>Section 8</b>	Page 14
Instrumentation .....	<b>Section 9</b>	Page 14
Mower Blade Maintenance.....	<b>Section 10</b>	Page 15
Greasing Bearings .....	<b>Section 11</b>	Page 15
How To Choose the Right Blade .....		Page 16
Mowing Tips .....		Page 17
Service Section.....		Page 18
Parts Section .....		Page 38
Limited Warranty .....		Page 64



## This manual applies to the following equipment:

### BadBoyMZSeries

- MZ 42" 540cc Briggs
- MZ 42" KT725 Kohler
- MZ Magnum 48" KT725 Kohler MZ
- Magnum 54" KT740 Kohler MZ
- Magnum 48" Kawasaki FR651V MZ
- Magnum 54" Kawasaki FR651V

## COMMONLY USED ITEMS AND PART NUMBERS

42" MZ Blade	Hi-Lift Fusion 038-4221-00	Gator Blade 038-4222-00	Wave Blade N/A
48" MZ Blade	Hi-Lift Fusion 038-4826-00	Gator Blade 038-4827-00	Wave Blade 038-4825-00
54" MZ Blade	Hi-Lift Fusion 038-0005-00	Gator Blade 038-0003-00	Wave Blade 038-5220-00
42" MZ Deck Belt	041-4022-00		
48" MZ Deck Belt	041-1470-00		
54" MZ Deck Belt	041-1560-00		
MZ Pump Belt	041-6400-00		
Oil Filter	Briggs Engine 063-8018-00	Kohler Engine 063-5004-00	Kawasaki Engine 068-8017-00
Air Filter	Briggs Engine 063-4026-00	Kohler Engine 063-5002-00 Pre-cleaner	Kawasaki Engine 063-2097-00
Fuel Filter	Briggs Engine 063-6000-00	Kohler Engine 063-5001-00	Kawasaki Engine 063-6000-00
Spark Plug	Briggs Engine 015-8000-00	Kohler Engine 015-8000-00	Kawasaki Engine 015-8001-00
Motor Oil	10W-30 Motor Oil - Bad Boy Synthetic Blend Motor Oil Recommended.		

---

## SECTION 1: BASIC INFORMATION

Congratulations on the purchase of your new Bad Boy Mower! The purpose of this manual is to assist operators in maintaining and operating their machine. The information and instructions in this manual can help you attain years of performance from your new Bad Boy. Also, check out our website to learn more about the Bad Boy family.

- 1.1 All Bad Boy engines use 10W-30 engine oil. For maximum protection, Bad Boy synthetic blend engine oil is recommended.
- 1.2 All Bad Boy Mowers use hi-temp multi-purpose grease. NLGI No. 2 for the grease fittings. MZ
- 1.3 models have 12 psi in both front and rear tires.
- 1.4 Most Briggs, Kohler, and Kawasaki engines hold approximately two (2) quarts of motor oil. Be careful not to over fill engine oil. Refer to the engine's service manual.

### Warranty Registration

The Warranty Registration form must be completed within 30 days to validate your warranty. As the new equipment owner, you are expected to see that the form is completed and forwarded to Bad Boy, Inc., at time of delivery. Warranty is non transferable. **Warranty registration should be completed by the selling dealership using the on-line registration site.**

### Model/Serial Number

Your MZ model serial numbers are found on the SIN plate underneath seat. These numbers can assist you in the ordering of new parts when replacements become necessary.

### Parts/Service

Only Bad Boy replacement parts are to be used on your mower.

Replacement parts are available through your local Bad Boy Mower Dealer. Remember to always provide the following information when ordering parts:

1. Correct part number
2. Correct serial number

All warranty repair and service must be handled through your authorized Bad Boy Mowers dealer.

To locate the nearest dealer, go to our website and click on Locate a Dealer.

## EVAPORATIVE EMISSION CONTROL WARRANTY STATEMENT

### ***Federal Evaporative Emission Control Warranty: Your Warranty Rights and Obligations***

The Environmental Protection Agency (EPA), and Bad Boy Inc. are pleased to explain the evaporative emission control system's warranty on your 2017 equipment. New equipment that uses spark ignition engines for off-road use must be meet stringent anti-smog standards.

The evaporative emission control system on your equipment is designed, built, and equipped so it conforms at the time of sale to the ultimate purchaser with the requirements of 40 CFR 1060. The evaporative emission control system is free from defects in materials and workmanship that may keep it from meeting said requirements. Bad Boy Inc. must warrant the evaporative emission control system on your equipment for two years provided there has been no abuse, neglect or improper maintenance. If an evaporative emission control system component does fail in a manner that would cause the equipment to no longer meet the requirements of 40 CFR 1060 within the first two years Bad Boy Inc. will replace the defective component. Your evaporative emission control system may include parts such as fuel tanks, fuel lines, carbon canisters, fuel caps, valves, vapor hoses, clamps, or connectors.



## SECTION 2: MOWER SAFETY GUIDELINES

Never allow untrained people to operate this machine. It is the owner's responsibility to get training and see to it that anyone who has permission to use your machine receives the proper training. Do not mow around people. The factory discharge chute is designed to deflect debris downward, but it could be possible for debris to be thrown in a way that can cause damage to people or property. Seek additional training when possible to learn more about safety techniques and practices. **This cutting machine is capable of amputating hands and feet and throwing objects. Failure to observe the following safety instructions could result in serious injury or death.**

### GENERAL OPERATION

- 2.1 Read, understand, and follow all instructions on the machine and in the manual before starting.
- 2.2 Do not put hands or feet near rotating parts or under the machine. Keep clear of the discharge opening at all times.
- 2.3 Always remain seated while operating the machine. If the machine is equipped with Roll Over Protection (ROPs), always buckle your seat belt.
- 2.4 Only allow responsible adults who are familiar with the instructions to operate this machine.
- 2.5 Clear the area of objects such as rocks, wire, toys, etc., which could be thrown by the blades.
- 2.6 Always maintain a safe distance from people and pets just prior to, and during, operation. Stop the machine if anyone enters the area.
- 2.7 Never carry passengers.
- 2.8 Do not mow in reverse unless absolutely necessary. Always look down and behind before and while backing.
- 2.9 Never direct discharged material toward anyone. Avoid discharging material against a wall or obstruction as material may ricochet back toward the operator. Stop the blades when crossing gravel surfaces.
- 2.10 Never operate the machine without the discharge chute, grass catcher, or other safety devices correctly in place and functioning properly.
- 2.11 Slow down before turning.
- 2.12 Always disengage blades, place steering controls in neutral, engage parking brake, and remove ignition key when leaving operators seat. Never leave a running machine unattended.
- 2.13 Disengage blades when not mowing. Shut off engine and wait for all parts to come to a complete stop before cleaning the machine, inspecting the machine for damage, removing the grass catcher, or unclogging the discharge guard.
- 2.14 Always operate machine in daylight or with adequate working lights.
- 2.15 Do not operate the machine while under the influence of alcohol or drugs.
- 2.16 Watch for traffic when operating near or crossing roadways.
- 2.17 Always wear eye protection when operating or servicing the machine.
- 2.18 Always wear ear protection, such as earplugs, while mowing.
- 2.19 Use extra care when loading or unloading the machine into a trailer or truck.
- 2.20 Be alert of surroundings. Watch for rocks, stumps, mounds, depressions, and low hanging limbs or objects that could be potentially hazardous while mowing.
- 2.21 Data indicates that operators 60 years of age and above are involved in a large percentage of riding mower related injuries. These operators should periodically evaluate their ability to operate the riding mower safely enough to protect themselves and others from serious injury.

---

## SETTING DECK HEIGHT

- 2.22 If your machine is equipped with an actuator motor, raise the deck using the raise /lower switch. Refer to section 7 (Controls). When deck is raised, set desired height with the deck height control dial, then lower deck with the raise / lower switch.
- 2.23 If your machine is equipped with a foot pedal, press foot pedal to raise deck, select your desired deck height with the deck height dial, then slowly release foot pedal.

## SLOPE OPERATION

Slopes are a major factor related to loss of control and tip over accidents, which can result in severe injury or death. Operation on all slopes requires extra caution. If you cannot back up the slope, or you feel uneasy on it, do not mow it.

- 2.24 Mow up and down slopes, not across.
- 2.25 Watch for holes, ruts, bumps, rocks, or other hidden objects that tall grass can obscure. Uneven terrain could overturn the machine.
- 2.26 Choose a low ground speed when operating the machine on a slope.
- 2.27 Do not mow on wet grass, the tires may lose traction.
- 2.28 Do not attempt to coast down a slope in the neutral position.
- 2.29 Avoid starting, stopping, or turning on a slope. If the tires lose traction, disengage the blades and proceed slowly, straight down the slope.
- 2.30 Keep all movement on slopes slow and gradual. Sudden changes in speed or direction could cause the machine to roll over.
- 2.31 Use extra care while operating machine with grass catchers or other attachments: they can affect the stability of the machine. Do not use on steep slopes.
- 2.32 Do not try to stabilize the machine by putting your foot on the ground.
- 2.33 Do not mow near drop offs, ditches or embankments. The machine could suddenly roll over if a wheel goes over the edge or the edge caves in.
- 2.34 Be aware of what is located at the bottom of slopes. For example: rocks water, cliffs, and roadways.

## CHILDREN

Tragic accidents can occur if the operator is not alert to the presence of children. Children are often attracted to the machine and the mowing activity. NEVER assume that children will remain where you last saw them.

- 2.35 Keep children out of the mowing area and in the watchful care of a responsible adult other than the operator. 2.36 Maintain alertness and turn machine off if a child enters the area.
- 2.37 Before and while backing, look behind and down for small children.
- 2.38 Never carry children, even with the blades shut off. They may fall off and be seriously injured or interfere with safe machine operation. Children who have been given rides in the past may suddenly appear in the mowing area for another ride and be run over or backed over by the machine.
- 2.39 Never allow children to operate the machine.
- 2.40 Never leave key in the ignition, especially around children.
- 2.41 Use extreme care when approaching blind corners, shrubs, trees, or other objects that may block your view of a child.



---

## TOWING

- 2.42 Tow only with a machine that has a hitch specifically designed for towing. Do not attach towed equipment except at the hitch point.
- 2.43 Follow the manufacturer's recommendation for weight limits for towed equipment and towing on slopes.
- 2.44 Never allow children or others in or on towed equipment.
- 2.45 On slopes, the weight of the towed equipment may cause loss of traction and loss of control.
- 2.46 Travel slowly and allow extra distance to stop.

## SERVICE:

### SAFE HANDLING OF GASOLINE

To avoid personal injury or property damage, use extreme care in handling gasoline. Gasoline is extremely flammable and the vapors are explosive.

- 2.47 Extinguish all cigarettes, cigars, pipes, and all other sources of ignition.
- 2.48 Use only an approved gasoline container.
- 2.49 Never remove gas cap or add fuel with the engine running.
- 2.50 **Allow engine to cool before refueling.**
- 2.51 **Never fuel the machine indoors.**
- 2.52 Do not store machine near open flame or source of ignition, such as a water heater or furnace.
- 2.53 Remove gas powered equipment from the truck or trailer and refuel it on the ground. If this is not possible, then refuel such equipment with a portable container, rather than from a gasoline dispenser nozzle.
- 2.54 Never fill gasoline containers inside a vehicle or on a truck or trailer bed with a plastic liner. Always place containers on the ground away from your vehicle before filling.
- 2.55 Keep the nozzle in contact with the rim of the fuel tank or container opening at all times until the fueling is complete. Do not use a nozzle lock-open device.
- 2.56 If fuel is spilled on clothing, change clothing immediately.
- 2.57 Never overfill fuel tank. Replace gas cap and tighten securely. **Tank is full when level reaches bottom of fill tube.**

## GENERAL SERVICE

- 2.58 Never operate machine in a closed area where dangerous carbon monoxide fumes can collect.
- 2.59 Keep all nuts and bolts tight to be sure the equipment is in safe working condition. Never operate a poorly maintained machine.
- 2.60 Do not touch hot areas of the machine.
- 2.61 Never interfere with the intended function of a safety device or reduce the protection provided by a safety device. Check their proper operation regularly.

- 
- 2.62 Keep the entire machine free of grass, leaves, or other debris build up. Clean up oil or fuel spillage and remove any fuel soaked debris. Failure to do so can affect the safety and functionality of the machine, as well as increase the danger of a fire due to contact with the hot surfaces of the machine.
  - 2.63 Allow machine to cool before storing.
  - 2.64 If you strike something with the mower, turn the mower and blades off, engage the parking brake, and inspect the machine for damage. Repair, if necessary, before resuming.
  - 2.65 Never make any adjustments or repairs with the engine running.
  - 2.66 Check grass catcher components and the discharge guard frequently and replace with manufacturer's recommended parts, when necessary.
  - 2.67 Mower blades are sharp. Wrap the blade or wear gloves before servicing them.
  - 2.68 Check parking brake operation frequently. Adjust and service as required.
  - 2.69 Maintain or replace safety and instruction labels, as necessary.
  - 2.70 Do not attempt to mount a tire without the proper equipment and experience to perform the job.
  - 2.71 Always maintain the correct tire pressure. Do not inflate the tires above the recommended pressure. Never weld or heat a wheel and tire assembly. The heat can cause an increase in air pressure resulting in a tire explosion. Welding can structurally weaken or deform the wheel.
  - 2.72 Park machine on level ground. Never allow untrained personnel to service machine. Understand service procedure before doing work.
  - 2.73 Mower deck, frame, and engine compartment should remain free of debris to prevent premature parts failures or fire hazards.

## SAFETY INTERLOCK SYSTEM

Your Bad Boy mower is equipped with a safety interlock system. This system is designed to prevent serious injury or death to the operator and other people or property damage. The system consists of an operator presence switch in the seat, the parking brake, drive lever neutral position, the mower blade engagement switch, and the ignition switch.

These interlocks are vitally important and must be tested frequently. Following are instructions to test these very important safety precautions. **Note: the operator must be seated properly on the machine during these tests and the engine should have been previously allowed to warm to operating temperature.**

- 2.74 With the parking brake engaged, bring lever arms to their inward position. Attempt to start the machine with the blade actuator in off position. The engine should not start.
- 2.75 On a level surface, disengage the parking brake and place lever arms to their outward position. Then attempt to start the machine with the blade actuator in off position. The engine should not start.
- 2.76 Engage parking brake and leave lever arms in outward position. Put blade actuator in the on position, then attempt to start the machine. The engine should not start.
- 2.77 Next, start the engine as stated in the Mower Operation Section. Disengage parking brake and Very Slowly begin to rise from the seat. The engine should stop.

If any of these tests fail to produce the results indicated and the problem cannot be identified, contact your Bad Boy Mower dealer or the support contacts in the rear of this manual.





## SECTION 3: MOWER OPERATION

***Never operate the machine with faulty equipment. Always be alert of sudden changes in landscape, as the mower will react differently on slopes or embankments than it will on flat surfaces. Never operate the mower with the discharge chute open. Do not cross terrain, other than grass, with blades turning. This could cause damage to property or bystanders.***

- 3.1 Place parking brake in up position
- 3.2 Drive arms must be in the “open” position. While sitting on the machine, each arm is positioned away from the operator, to the right and left. Drive arms will lock into place and must be in this position to start machine.
- 3.3 Put PTO switch in the OFF position.
- 3.4 If your machine has been equipped with a ROPS (Roll Over Protection System) then you must fasten seatbelt.
- 3.5 If machine has not been started recently, engage the choke.
- 3.6 Make sure nothing is under or around machine.
- 3.7 Place key in ignition and turn.
- 3.8 Once machine is started, disengage the choke.
- 3.9 Increase RPM by sliding the throttle to fast position, toward the rabbit.
- 3.10 Owners must become familiar with the controls before operating a zero-turn radius vehicle.
- 3.11 Start slowly and build your skill level. Have ample practice before using the machine at full capabilities.
- 3.12 Be comfortable with machine before engaging blades. Know what each component controls before using machine.
- 3.13 Your mower will perform differently on an incline /decline. Be cautious, slow down, and do not make any sudden jerking movements with control arms. The machine could lose traction on a decline or tip backwards on an incline.
- 3.14 Once you become comfortable with your Bad Boy Mower you will notice your overall mowing time will decrease.

***Avoid operating your mower on side hills of over 5 degrees,  
inclines of over 10 degrees,  
and declines of over 15 degrees.***

# SECTION 4: MOWER MAINTENANCE

Maintenance	Interval							Section
	Daily	First 8 hours	Every 25 hours	Every 50 hours or annually*	Every 100 hours or annually*	Every 200 hours	Every 250 hours	
Check and add engine oil	•							Section 3
Check all belts for proper alignment	•							Section 2 (Pump) 6 (Deck)
Check tire pressure and wheel lug nuts	•							Section 5
Check battery terminal connections	•							Section 4
Check condition of blades	•							Section 6
Check for fuel and oil leakage	•							Section 3
Initial oil change		•						Section 3
Tighten nuts and screws				•				Section 5
Change engine oil and filter				•				Section 3
Grease mower					•			
Replace air element and pre-cleaner ◊					•			Section 3
Replace fuel filter ◊					•			Section 3
Clean or replace spark plugs and set gap					•			Section 3
Clean combustion chamber <sup>Dealer</sup>							•	
Check and adjust valve clearance <sup>Dealer</sup>							•	
Clean and lap valve seating surface <sup>Dealer</sup>							•	

\*Maintenance by hour or annually which ever come first  
 ◊ Check air and fuel filter more often in dusty conditions  
<sup>Dealer</sup> Get maintenance performed at a registered dealership

# SECTION 5: MOWER STORAGE & TRANSPORTATION

- 5.1 Keep machine from collecting debris by storing in a covered area while not in use.
- 5.2 Fuel can harm your machine if left for more than 30 days without changing, especially if the fuel contains ethanol. Never use fuel with more than 10% ethanol by volume. E-15 is not permitted.
- 5.3 Disconnect the negative battery cable when machine will be stored for more than 30 days.
- 5.4 Always secure machine properly when transporting machine.
- 5.5 Do not load machine on trailer with blades engaged.
- 5.6 Do not use ramps to load the machine.
- 5.7 Make sure Parking Brake is in “up” position.
- 5.8 In wet conditions tires may spin while loading / unloading. If necessary, wait for dry conditions before loading / unloading.
- 5.9 Make sure mode of transportation is suitable to bear the weight of mower.
- 5.10 Deck height should be set at maximum before attempting to load.
- 5.11 Secure mower with at least two straps capable of securing weight of mower.



# MAINTENANCE LOG

<i>Date:</i>	<i>Hours:</i>	<i>Performed:</i>
<i>Date:</i>	<i>Hours:</i>	<i>Performed:</i>
<i>Date:</i>	<i>Hours:</i>	<i>Performed:</i>
<i>Date:</i>	<i>Hours:</i>	<i>Performed:</i>
<i>Date:</i>	<i>Hours:</i>	<i>Performed:</i>
<i>Date:</i>	<i>Hours:</i>	<i>Performed:</i>
<i>Date:</i>	<i>Hours:</i>	<i>Performed:</i>
<i>Date:</i>	<i>Hours:</i>	<i>Performed:</i>
<i>Date:</i>	<i>Hours:</i>	<i>Performed:</i>
<i>Date:</i>	<i>Hours:</i>	<i>Performed:</i>
<i>Date:</i>	<i>Hours:</i>	<i>Performed:</i>
<i>Date:</i>	<i>Hours:</i>	<i>Performed:</i>
<i>Date:</i>	<i>Hours:</i>	<i>Performed:</i>
<i>Date:</i>	<i>Hours:</i>	<i>Performed:</i>
<i>Date:</i>	<i>Hours:</i>	<i>Performed:</i>
<i>Date:</i>	<i>Hours:</i>	<i>Performed:</i>
<i>Date:</i>	<i>Hours:</i>	<i>Performed:</i>
<i>Date:</i>	<i>Hours:</i>	<i>Performed:</i>
<i>Date:</i>	<i>Hours:</i>	<i>Performed:</i>
<i>Date:</i>	<i>Hours:</i>	<i>Performed:</i>
<i>Date:</i>	<i>Hours:</i>	<i>Performed:</i>
<i>Date:</i>	<i>Hours:</i>	<i>Performed:</i>

---

## SECTION 6: TROUBLESHOOTING

6.1 **Q:** *How do I prevent an uneven cutting pattern and increase the quality of cut?*

6.1 **A:** Check tire pressure, check blade sharpness (replace blades or sharpen at least once per year or when needed), make sure blades are tightened properly, check spring and belt tension, check the underside of the deck to ensure the mower deck is free of grass build-up and debris, make sure your machine is at full throttle, and vary your mowing pattern each time you cut your grass.

6.2 **Q:** *What should I do if my mower won't start?*

6.2 **A:** Check battery charge and connection (grounds), check your fuel (make sure fuel is less than 30 days old and contains no water), make sure your spark plug is in good condition and spark plug wire is attached, and make sure air filter is clean (a dirty filter makes it more difficult for the engine to draw air). Check the integrity of the 25 amp main fuse; also check for any bare wires and/or bad connections.

6.3 **Q:** *What should I do if the blades won't engage?*

6.3 **A:** Make sure the safety switch is plugged in on the bottom of seat. Check the underside of the PTO engager to ensure the plug is secure at switch. Also check PTO fuse underneath operator console (10amps)

6.4 **Q:** *What type of fuel is recommended for my mower?*

6.4 **A:** We recommend that you use a name brand fuel to ensure quality. Use fuel with an octane rating near 87. Higher octane fuels offer no benefit. Only fuels with an ethanol content of 10% or less may be used. By law, E-15 fuel is not permitted. Usage of E-15 will result in premature engine failure.

6.5 **Q:** *Do you offer touch-up paint for your mowers?*

6.5 **A:** Touch-up paint is available. Contact your local dealer for more information.

6.6 **Q:** *How do I clean my mower?*

6.6 **A:** It is recommended that you use an air hose or blower to remove dust and debris from the mower, to ensure there is not a build up of grass on the mower deck and engine compartment, which could become a fire hazard. If you must wash the mower, ensure you run the engine to operating temp to dry water and engage the blades to spin off any standing water on the pulleys. Avoid spraying water onto electrical components and bearings, to prevent premature failure of these parts.



## SECTION 7: CONTROLS

- 7.1 **Ignition Switch**—Bad Boy mowers have a three position ignition switch: off, run, and start. With key inserted, rotate it clockwise to START position and release key when engine starts, and switch will automatically return to the RUN position.
- 7.2 **Throttle Control**—A cable is connected to the engine throttle for controlling engine speed. Move lever forward to increase engine rpm, move lever backward to decrease engine rpm.
- 7.3 **Choke Control**—(Not Shown) The choke control, located to the right of the operator's left, is a 'push-pull' type. When the choke knob is pushed in, the choke is in the off (run) position. When the choke is pulled out it is in the on (start) position. **Do not operate the machine in the on (start) position.**
- 7.4 **Control Levers**—These levers control the mower's speed, direction, and neutral lock. These levers are used to steer, accelerate, decelerate and change direction.
- 7.5 **Blade Engage Switch**—This switch engages the blades. Pull the switch up to engage the blades and push the switch down to disengage the blades.
- 7.6 **Deck Height Control**—The deck height dial is used to set the cut of the deck.

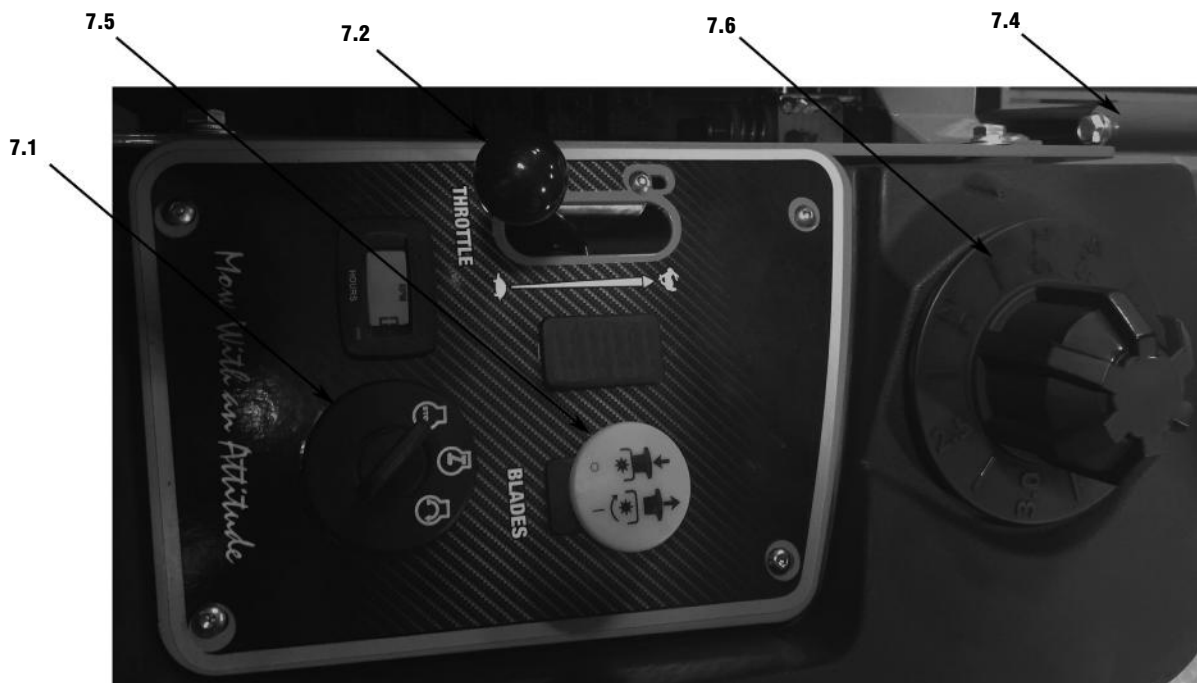

---

## SECTION 8: MOVING INOPERABLE MOWER

- 8.1 Do not tow machine. Use a winch to load on a trailer for transporting.
- 8.2 MZ Models are equipped with two neutral engage/disengage arms, located at the rear of the mower protruding from the frame and under the muffler. By pulling the arms out, the mower can be put in a neutral position. Return the arms to the “forward position” for normal operation.

Your Bad Boy Mower Weighs:                      ***MZ SERIES:***                      ***585—602 lbs***

*\*\*\* Weights fluctuate with the addition of accessories.*

- 8.3 As you can see by the weights of the machines, you shouldn't ever try to push or pull a Bad Boy Mower by hand. This could cause serious bodily injury.
- 8.4 Hopefully, you'll never need to use this section of the manual. However, if you do, use extreme caution when moving machine!

## SECTION 9: INSTRUMENTATION

- 9.1 **Electronic Hour Meter**—Registers Hour increments up to 9,999.9 total hours. This meter records the cumulative time the engine is running. (This is standard on the MZ Magnum and is an option on the MZ Series.)



---

## SECTION 10: MOWER BLADE MAINTENANCE

- 10.1 Check mower blades after each use. This is essential for maintaining well-groomed turf. Keep the blades sharp. If a dull blade is used for cutting, the grass will tear rather than cut. This could damage the grass leaving a brown frayed top on the grass within a few hours. A dull blade will also require more power from the engine.
- 10.2 NEVER attempt to straighten a bent blade by heating. NEVER attempt to weld a cracked blade. The blades can break and cause serious injury or death.
- 10.3 NEVER work with blades while engine is running or deck clutch is engaged.
- 10.4 ALWAYS place deck clutch in DISENGAGE position while performing maintenance.
- 10.5 Use blocks when you MUST work under mower.
- 10.6 ALWAYS wear thick gloves when handling blades.
- 10.7 ALWAYS check for blade damage if mower strikes rock, branch, or other objects that could potentially damage the blade.

***(REMEMBER: NEVER CHECK BLADE WHILE ENGINE IS ON!  
NEVER CHECK BLADES WHILE BLADES ARE ENGAGED!)***

## SECTION 11: EQUIPMENT LUBRICATION

- 11.1 Park the machine on a level surface and disengage the blade control switch.
- 11.2 Move the motion control levers outward to the neutral position, engage parking brake, stop the engine, remove the key, and wait for all moving parts to stop before leaving the operating position.
- 11.3 Grease Type: NLGI grade #2 multi-purpose gun grease.
- 11.4 Clean the grease fittings with a cloth. Scrape any paint off the front of the fitting(s).
- 11.5 Connect a grease gun to each fitting. Pump grease into the fitting until grease seepage is observed. Be mindful of over-pressurization. Do not force the lever arm if there is strong back pressure as this can lead to reduced life of the component(s). Wipe up excess grease.
- 11.6 Refer to service manual section for grease fitting locations.

---

# HOW TO CHOOSE THE RIGHT BLADE

Essentially there are only TWO basic styles of mowing blades used or approved for use on our current products:

- 1) The standard style of mowing blade is essentially designed for cutting grass and effectively discharging the clippings out from the deck to fall onto the lawn or to be captured in a grass collection system. Standard blades are also referred to as “2-in-1” (discharging & bagging ) or “high-lift” blades (because they are designed to create a higher-lifting airflow).
- 2) Mulching blades generally have a more curved style surface and frequently include extra cutting surfaces along the blade edges. These blades may also come in a “+” design (which is actually two individual blades arranged in a perpendicular fashion to enhance mulching). The “+” blades are usually found on older style mowers; newer ones utilize blades with more advanced mulching technology. Mulching blades may also be referred to as “3-in-1” (mulching, discharging & bagging) or “all-purpose” blades.

Bear in mind that the re-circulating airflow design of 3/1 blades makes them less efficient at discharging grass clippings than a standard 2/1 blade. As with most all-purpose tools, there is some give and take as opposed to using a tool designed for a more specific purpose.

If you're experiencing less-than-desired cutting or discharging performance with a 3/1 blade, you may want to check into using a 2/1 blade. Conversely, if you're using a 2/1 blade and want to mulch clippings, you should see about the availability of mulching blades or a mulching kit.\*

The type of blade installed on a new mower is a decision the retailer makes for each model of mower, based on the expected needs of most customers. If you're unsure of which blade is on a particular model, inspect the blade. Blades have part numbers stamped into them. Then compare these part numbers with the unit's Operator's Manual or Parts List.

It is true there are many other styles of blades available. But since we don't manufacture or recommend using these other aftermarket styles, we will leave them out of this discussion. Should you want more information on special application or aftermarket blades, you should contact the companies that make these products. NOTE: Customers using non-OEM blades do so at their own risk. The use of unapproved (non-OEM) blades may void any or all of the mower and engine factory warranties.

\* **MULCHING KITS** – These generally consist of mulching blades and a mulching plug (which closes off the discharge opening to keep the clippings contained under the deck for re-cutting) plus any necessary hardware for installation. Please check with your parts distributor regarding the contents of a particular mulching kit.





## MOWING TIPS:

- Mow header strips at the ends of the lawn and around flower beds first. Make them wide enough that you can turn the mower around in the already mown section. Then mow back and forth between these header strips overlapping each lap by about 1/8 the width of the mower's deck.
- Don't cut your grass too short, particular for cool season grasses. Higher heights usually provide for a deeper root system, looks better, and is less likely to have weeds invading, particularly crabgrass.
- Don't remove any more than one third of the grass leaf at any one cutting. If circumstances arise that a lawn gets too tall and you just have to lop off a bunch to get caught up, bite the bullet and break it down into several mowings to get caught up with 3 or so days between cuttings.
- **NEVER SCALP YOUR LAWN.** Scalping severely damages the root system to such a degree that it may die.
- Avoid mowing when the grass is wet or when it's dark
- Avoid throwing grass clippings into the street and driveway where they can be washed into the sewer system. After mowing, clean up driveway and walkways.
- When mowing remove only a third with each cutting (except for the first mowing of the season when it's ok to remove more). You can safely leave clippings that will quickly decompose and add nutrients back into the soil. Contrary to popular opinion, grass clippings do not add to thatch buildup. Grass blades are made up of about 75% water.
- Mow your lawn in a different direction with each mowing, especially with lawns of shorter grass types. Altering the direction ensures a more even cut since grass blades will grow more erect and less likely to develop into a set pattern.
- Keep your mower's blade sharp, which means having it sharpened several times during the mowing season. Keep several blades around so you'll always have a sharp one on hand. Sharp blades cut the grass cleanly and help mulch clippings into small pieces which break down quickly.
- Don't forget to change your mower's oil at least once during the mowing season. For brand new mowers, change the oil after about 5 hours of operation during the initial break-in period.
- At the end of the mowing season use a fuel stabilizer in the remaining gasoline
- In the spring, don't use that old gas unless you properly used a fuel stabilizer, it can cause a number of problems. Better to use fresh gasoline to begin the new mowing season.
- **Leaf blade A** demonstrates what a leaf blade should look like after mowing with a sharp blade.
- **Leaf blade B** demonstrates a leaf blade that was injured by a dull mower blade.
- **Leaf blade C** was cut by the mower but indicates that the mower blade is not sharp enough. The shredded white tissue protruding from the leaf blades C and D is the vascular tissue of the plant.
- **Leaf blade D** has been mown for quite some time with a dull mower blade.



## *To bag or mulch?*

Grass clippings do not contribute to thatch buildup or increase the chances of disease. If you mow your lawn at the right height, without removing any more than 1/3 of it's total height, clippings will quickly breakdown without a trace. These clippings contribute additional nitrogen and other nutrients to the soil and supply it with additional organic materials. Clippings from a 1000 sq. ft. lawn can add as much as 1 - 2 pounds of nitrogen back into the soil.

If you have a compost pile, then you may want to bag your clippings occasionally to add much needed green-matter to the compost pile. Make sure it is mixed thoroughly with brown matter to avoid a strong ammonia odor. **DO NOT COMPOST CLIPPINGS** after applying any weed control or weed-feed type product. Before adding clippings to the compost pile wait at least 3 mowings after these products have been applied.

---

# SERVICE SECTION

## SECTION 1: HYDROSTATIC SYSTEM

The hydrostatic system on MZ models is a sealed lifetime transaxle system, so no maintenance is required. Under the rear of the mower, you will find the two levers shown in the image. These bypass levers serve as a neutral for moving the mower while the engine is not running. Pull the levers out and lock them into place to activate the bypass.

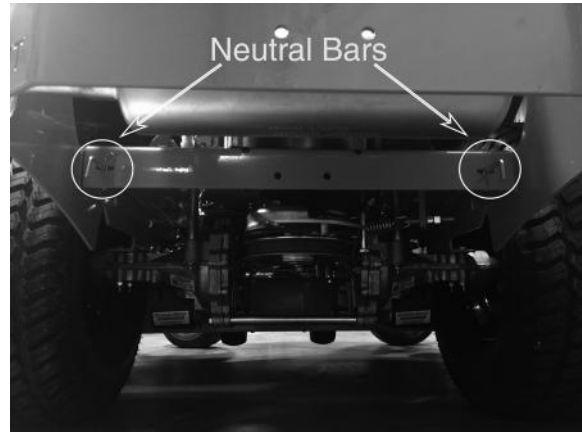

When adjusting the tracking on the mower, the length of the pushrods can be changed by screwing the swivel joint in or out on the ends of the rods. Shortening the overall length of the rod slows the pump down. Lengthening the rod will increase the speed of the pump.

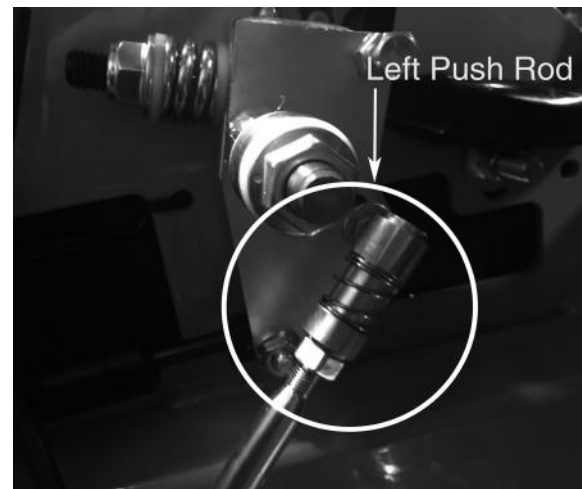
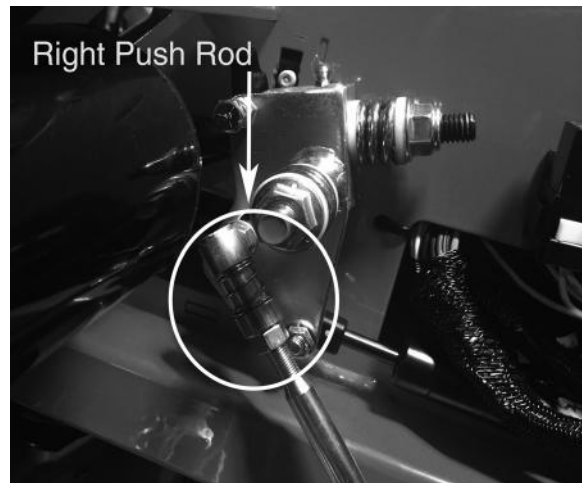



## SECTION 2: DRIVE BELT

Shown to the right is the MZ pump belt tensioner. Tightening the two 3/4" jam nuts on the right side will increase the belt tension.



The tension should be adjusted so that there is between 60 to 65 lbs. of tension on the belt. This can be checked with a belt tension gauge as shown to the right.



## SECTION 3: ENGINE

### 540cc BRIGGS

This machine has an oil drain hose installed on the engine to allow for easier oil changes. Bad Boy recommends that the oil and filter be changed after the initial 8 hrs of use, and at intervals of 50 usage hours or yearly, whichever occurs first after that. The oil capacity is 2 quarts. Bad Boy 10W-30 synthetic blend engine oil is recommended for maximum protection.

The fuel filter is located in the fuel line about 12" from the carburetor on the side of the engine. Replace the filter yearly. Prior to the removal of the old filter, note the direction of fuel flow as indicated on the filter. Have towels readily available in order to quickly remove any fuel leakage. Always use new hose clamps and ensure the security of the new filter by lightly pulling on each hose. Always perform maintenance outdoors or in a well ventilated area. Do not smoke or allow any open flames in the vicinity of any maintenance activities.

The air cleaner is the engine's only defense against damaging foreign particles. It is very important that the air cleaner element is inspected prior to each use. Remove the element and tap its sides in order to remove debris. Do not blow the filter out using compressed air. Doing so will greatly reduce the air cleaner's effectiveness. Replace yearly; more often in dusty environments. Adhering to these practices will help prevent loss of power and premature engine failure.

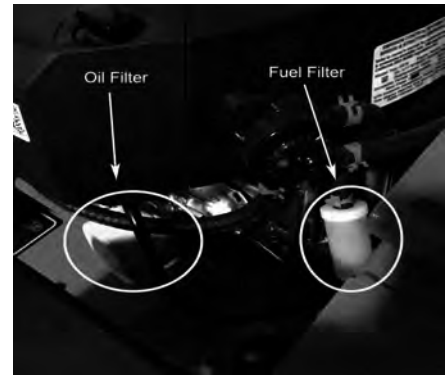
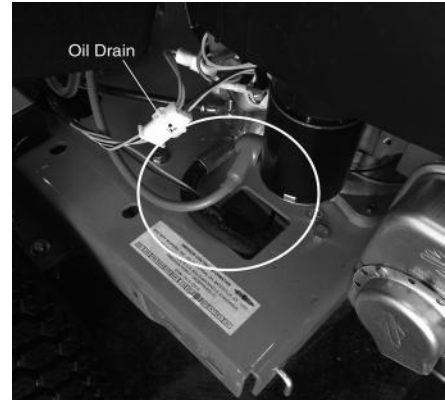



### 3.1 Changing the Spark Plug:

1) In order to access the spark plug you: will need to remove the rear engine cover. This can be done by removing the four carriage bolts in the rear with a 1/2" wrench.



2) Remove the ignition wire from the spark plug and using a 5/8" deep socket and extension take the spark plug off of the engine.



3) Check the spark plug gap or insert your new spark plug.



4) When re-installing spark plug do not overtighten the spark plug.

---

## KOHLER

This machine has an oil drain hose installed on the engine to allow for easier oil changes. Bad Boy recommends that the oil and filter be changed after the initial 8 hrs of use, and at intervals of 50 usage hours or yearly, whichever occurs first after that. The oil capacity is 2 quarts. Bad Boy 10W-30 synthetic blend engine oil is recommended for maximum protection.

### 3.1 Changing your engine oil and oil filter:

- 1) Remove oil dipstick and open oil drain. Allow oil to completely drain. (Make sure to have an oil pan ready to capture old oil and properly dispose old oil.)
- 2) Clean area around oil filter. Place a container under the oil filter to capture any oil and remove filter. Wipe off mounting surface and reinstall drain plug. Torque to 10 ft\*lb.
- 3) Place new filter in shallow pan with open end up. Fill with new oil until oil reaches the bottom of the threads. Allow 2 minutes for oil to be absorbed by filter material.
- 4) Apply a thin film of clean oil to rubber gasket on new filter
- 5) Refer to instructions on oil filter for proper installation.

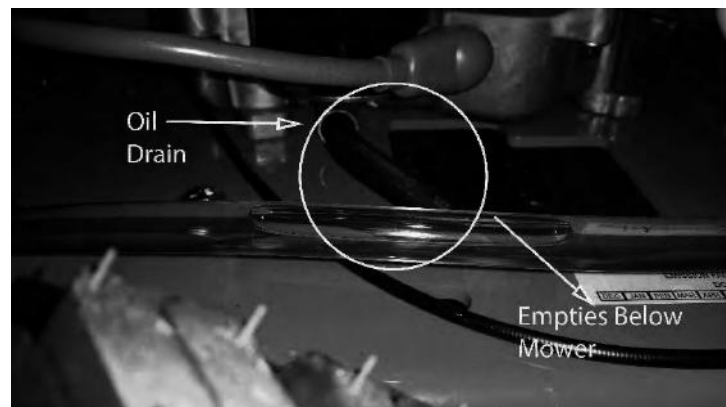
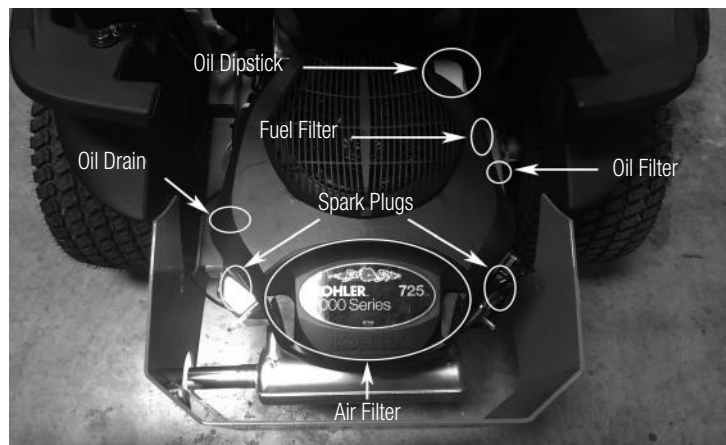



- 6) Fill crankcase with approximately 2 quarts of new oil. Level should reach top of indicator on dipstick.
- 7) Reinstall oil filter dipstick and tighten securely.
- 8) Start engine; check for oil leaks. Stop Engine; correct oil leaks. Recheck oil level.
- 9) Dispose of used oil and filter in accordance with local ordinances.

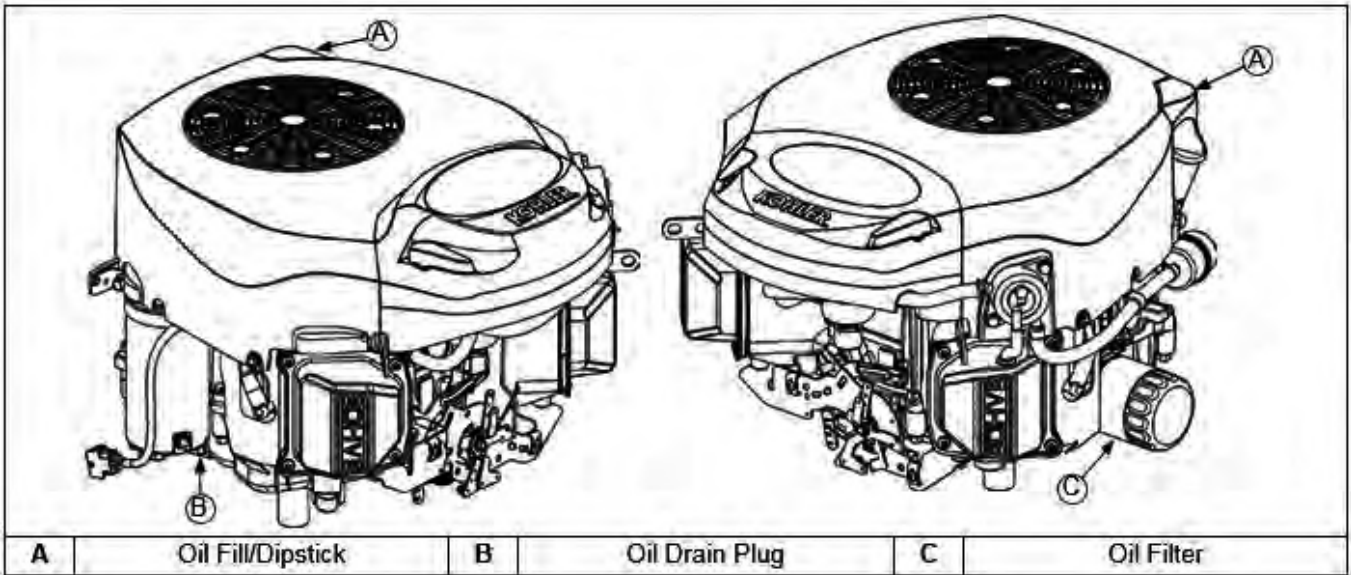

The fuel filter is located in the fuel line about 12" from the carburetor on the side of the engine. Replace the filter yearly. Prior to the removal of the old filter, note the direction of fuel flow as indicated on the filter. Have towels readily available in order to quickly remove any fuel leakage. Always use new hose clamps and ensure the security of the new filter by lightly pulling on each hose. Always perform maintenance outdoors or in a well ventilated area. Do not smoke or allow any open flames in the vicinity of any maintenance activities.

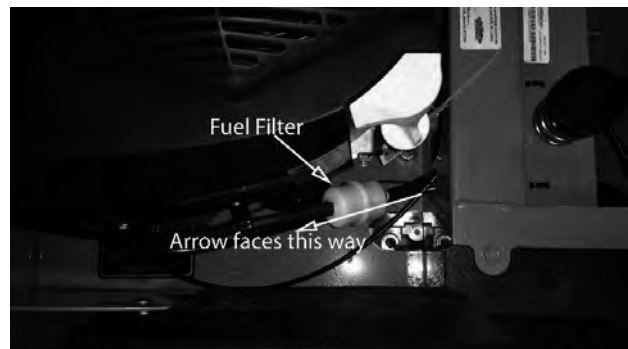

### 3.2 Changing your fuel filter:

- 1) Locate your fuel filter and mark the direction it is facing.
- 2) Clamp each side of the fuel filter to minimize any gas spills.
- 3) Remove the clips from each side of the fuel filter and remove the fuel filter.
- 4) Place the new fuel filter in the same direction as the old and place clips back into place and remove clamps.

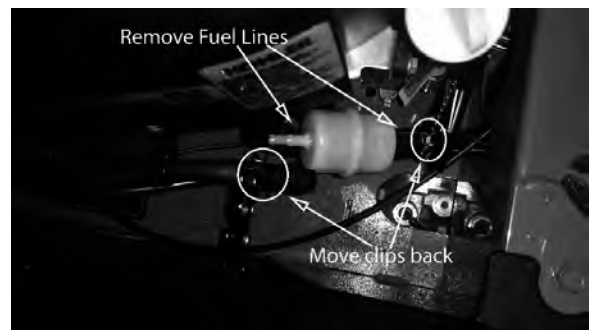
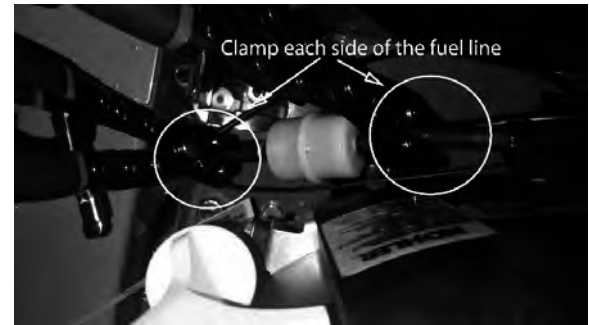

The air cleaner is the engine's only defense against damaging foreign particles. It is very important that the air cleaner element is inspected prior to each use. Remove the element and tap its sides in order to remove debris. Do not blow the filter out using compressed air. Doing so will greatly reduce the air cleaner's effectiveness. Replace yearly; more often in dusty environments. Adhering to these practices will help prevent loss of power and premature engine failure.

**Air Cleaner Components**

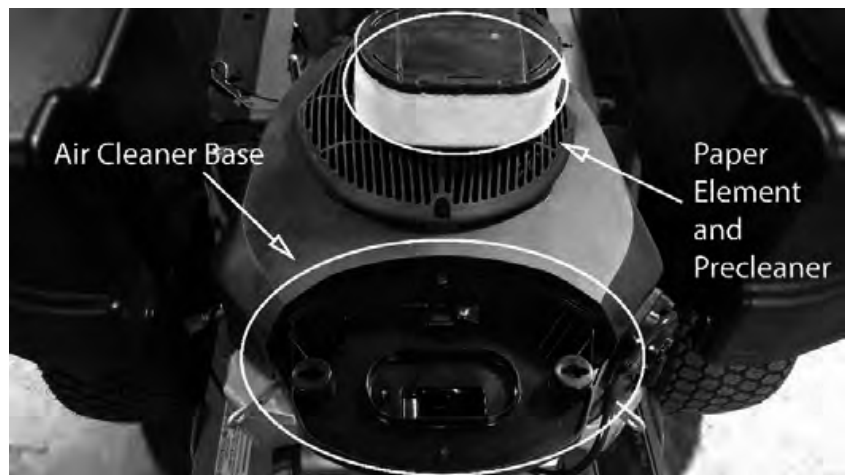
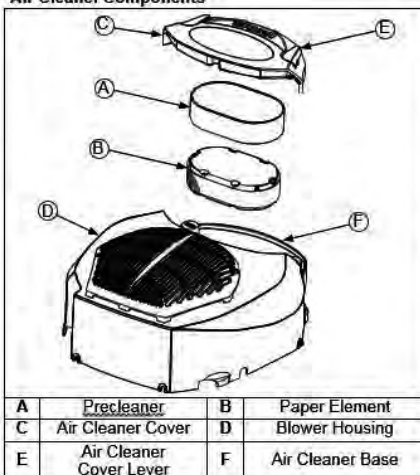



### 3.3 Changing the air cleaner:

- 1) Unlock the air cleaner cover and remove to access the air cleaner.
- 2) Remove the paper element and precleaner.
- 3) Replace or wash precleaner in warm water with detergent. Rinse and allow to air dry.
- 4) Lightly oil precleaner with new engine oil; squeeze out excess oil.
- 5) Replace paper element and place precleaner onto new paper element.
- 6) Install onto base and place cover back on and lock into place.

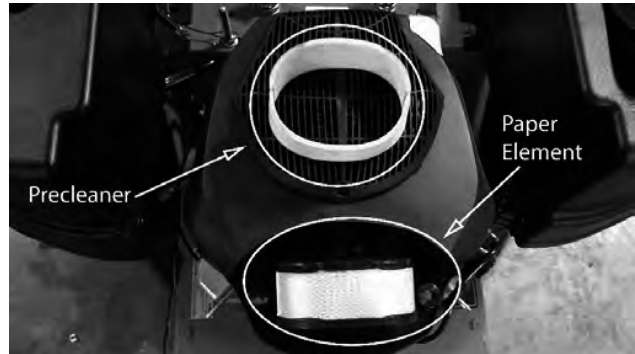

### 3.4 Changing the spark plugs and checking the spark plug gap:

- 1) In order to access the spark plugs you will need to remove the rear engine cover. This can be accomplished by removing the four carriage bolts using a 7/16" ratcheting wrench.
- 2) Remove the wire on the spark plug and use a 5/8" socket to remove the spark plug.
- 3) Check the gap on the spark plug to verify that it is 0.03 in using a feeler gauge.
- 4) If the spark plug is worn, overheated, wet or carbon fouled replace the spark plug.
- 5) Install the plug into Cylinder head and torque to 20 ft\*lbs. Be careful not to overtighten the spark plug.



**Spark Plug Component and Details**

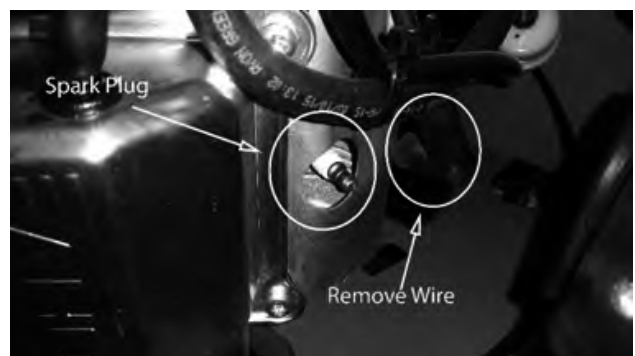
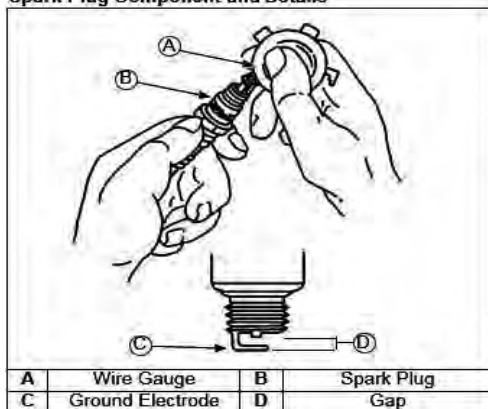

# KAWASAKI

This machine has an oil drain hose installed on the engine to allow for easier oil changes. Bad Boy recommends that the oil and filter be changed after the initial 8 hrs of use, and at intervals of 50 usage hours or yearly, whichever ever occurs first after that. The oil capacity is 2 quarts. Bad Boy 10W-30 synthetic blend engine oil is recommended for maximum protection.

## 3.1 Changing your engine oil and oil filter:

- 1) Remove oil dipstick and open oil drain using a 10 mm socket or a flat head screwdriver until oil begins flowing. Allow oil to completely drain. (Make sure to have an oil pan ready to capture old oil and properly dispose old oil.)
- 2) The oil filter is located on the right side of the engine. Clean area around oil filter. Place a container under the oil filter to capture any oil and remove filter. Wipe off mounting surface and reinstall drain plug. Torque to 10 ft\*-lb.
- 3) Place new filter in shallow pan with open end up. Fill with new oil until oil reaches the bottom of the threads. Allow 2 minutes for oil to be absorbed by filter material.
- 4) Apply a thin film of clean oil to rubber gasket on new filter
- 5) Refer to instructions on oil filter for proper installation.
- 6) Fill crankcase with approximately 2 quarts of new oil. Level should top of indicator on dipstick.
- 7) Reinstall oil fill/dipstick and tighten securely.
- 8) Start engine; check for oil leaks. Stop Engine; correct oil leaks. Recheck oil level.
- 9) Dispose of used oil and filter in accordance with local ordinances.

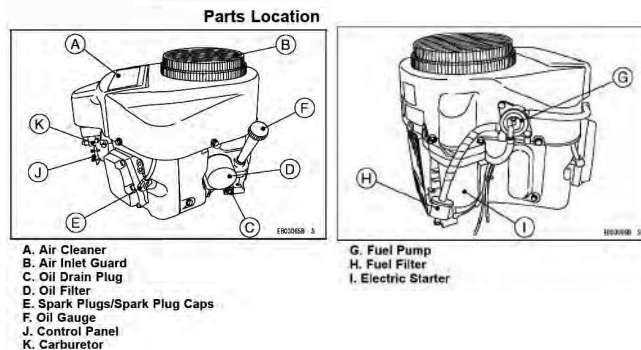
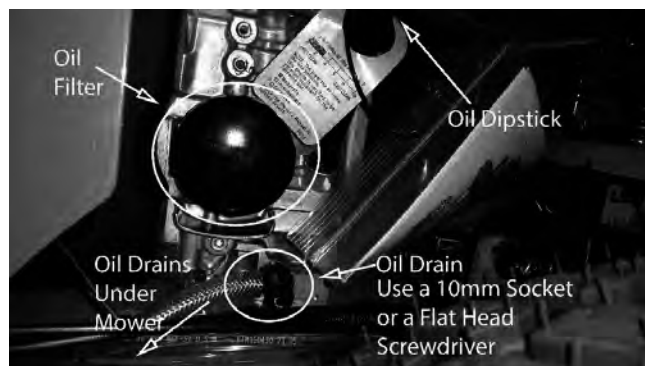
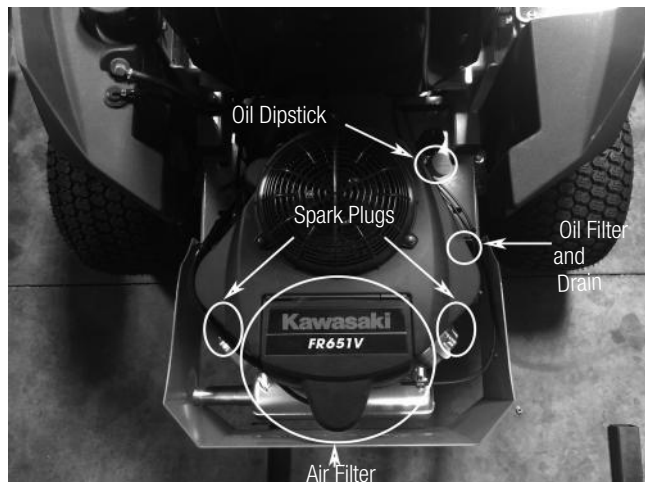



The fuel filter is located in the fuel line on the left side of the engine by the starter motor. Replace the filter yearly. Prior to the removal of the old filter, note the direction of fuel flow as indicated on the filter. Have towels readily available in order to quickly remove any fuel leakage. Always use new hose clamps and ensure the security of the new filter by lightly pulling on each hose. Always perform maintenance outdoors or in a well ventilated area. Do not smoke or allow any open flames in the vicinity of any maintenance activities.

### 3.2 Changing your fuel filter:

- 1) Locate your fuel filter and mark the direction it is facing.
  
- 2) Clamp each side of the fuel filter to minimize and gas spills.
  
- 3) Remove the clips from each side of the fuel filter and remove the fuel filter.
  
- 4) Place the new fuel filter in the same direction as the old and place clips back into place and remove clamps.

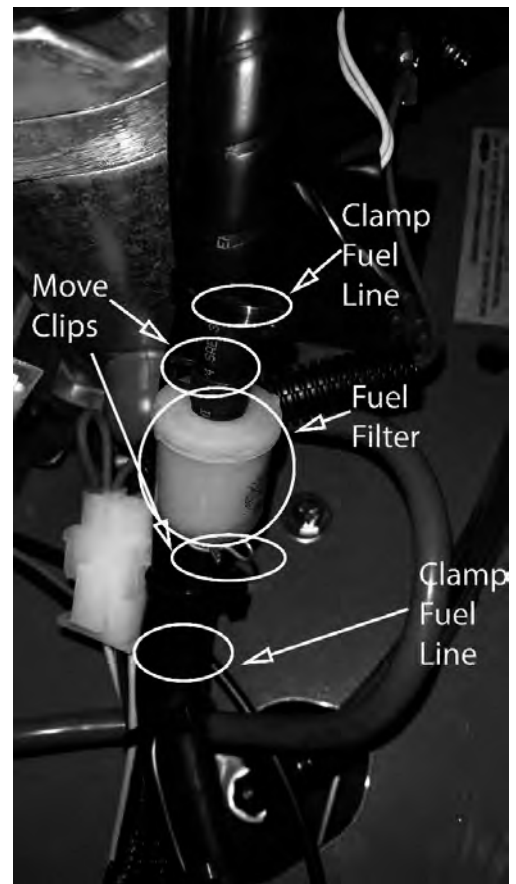

The air cleaner is the engine's only defense against damaging foreign particles. It is very important that the air cleaner element is inspected prior to each use. Remove the element and tap its sides in order to remove debris. Do not blow the filter out using compressed air. Doing so will greatly reduce the air cleaners effectiveness. Replace yearly; more often in dusty environments. Adhering to these practices will help prevent loss of power and premature engine failure.

### 3.3 Changing the air cleaner:

- 1) Locate the air filter and lift up the cover.
- 2) Loosen the tensioner on the right side of the air filter.
- 3) Clean or replace paper element.
- 4) Place the paper element back into place and tighten the tensioner.
- 5) Place cover back to original position.

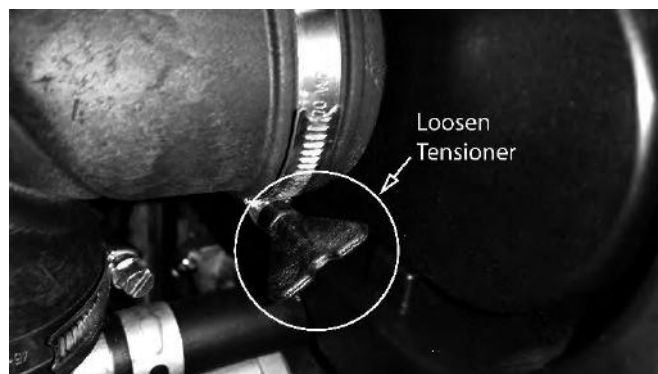
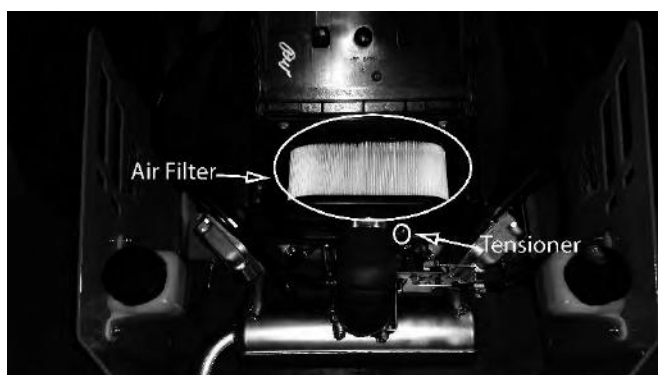



### 3.4 Changing the spark plugs and checking the spark plug gap:

- 1) Remove the wire on the spark plug and use a 13/16" socket to remove the spark plug.



- 2) Check the gap on the spark plug to verify that it is 0.03 in using a feeler gauge.



- 3) If the spark plug is worn, overheated, wet or carbon fouled replace the spark plug.

- 4) Install the plug into cylinder head and torque to 16 ft\*lbs. Be careful not to overtighten the spark plug.

**Spark Plug Component and Details**

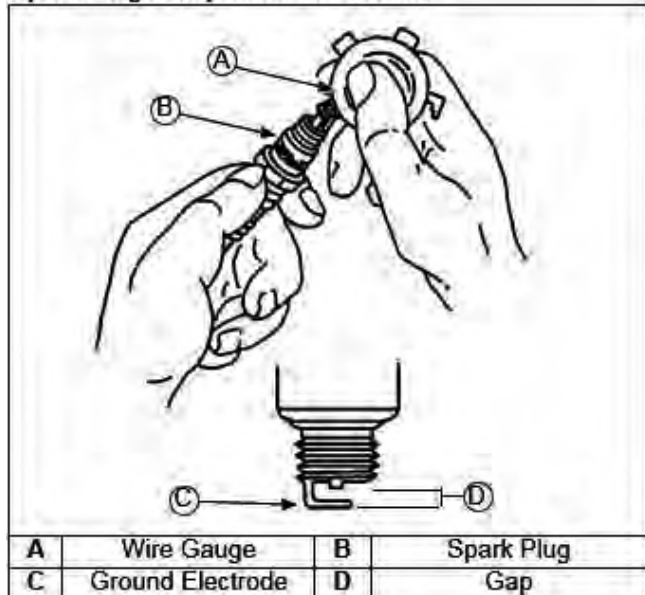

## SECTION 4: ELECTRICAL SYSTEM

This mower is equipped with two protective fuses: a 25 amp main fuse (pictured to the right) and a 10 amp clutch (blade engagement). The main fuse is located on the left side of the unit; towards the front of the engine. The Clutch fuse is located just underneath the control panel.

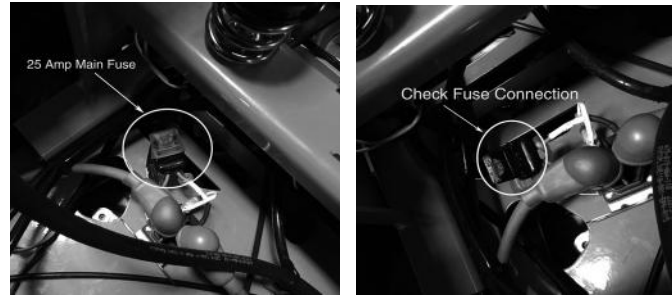

In order to access the clutch fuse and the relays you will need to take off the control panel by removing four socket head screws using a 1/8" hex wrench. This can be seen in the images on the right. Once you remove the screws remove the control panel and you can access the clutch fuse and the relay bank.

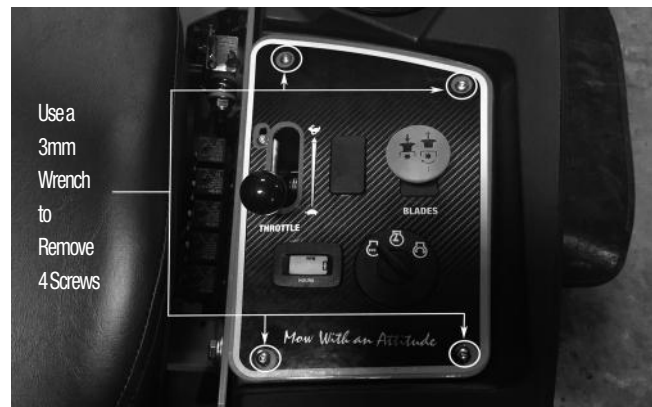

A blown fuse usually indicates a problem within the electrical system or an electrical component. Never replace a fuse with one of a higher amperage rating or "by pass" a fuse in any way. Doing so creates a significant fire hazard and can cause severe damage to the mower's electrical components. If a fuse is repeatedly blowing, contact your Bad Boy dealer.





On most models, the red wire coming out of the engine is the charging wire from the alternator. Check for 13.6 - 14.2 volts dc at this wire with engine at full throttle.

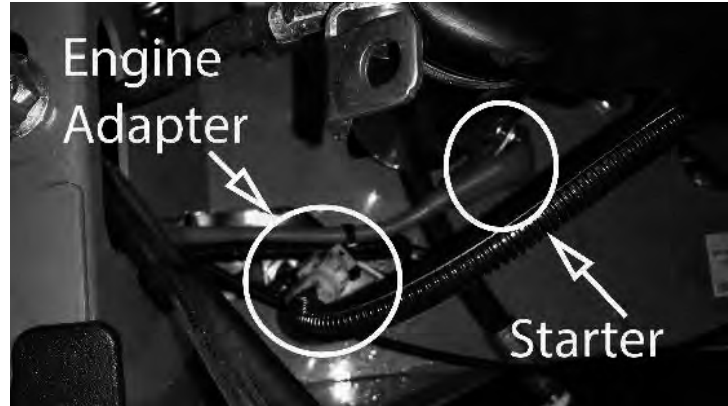

Check the condition and connection of the relays located under the control panel. Ensure that they are clean and connected. Make sure that wire terminal ends have not been pushed out of the relay block.

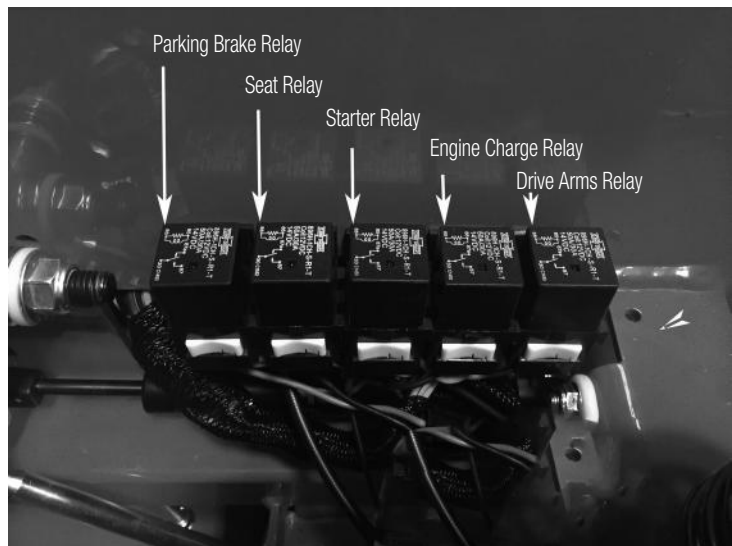

If you are having issues starting your mower ensure the signal wire is connected to your starter solenoid.



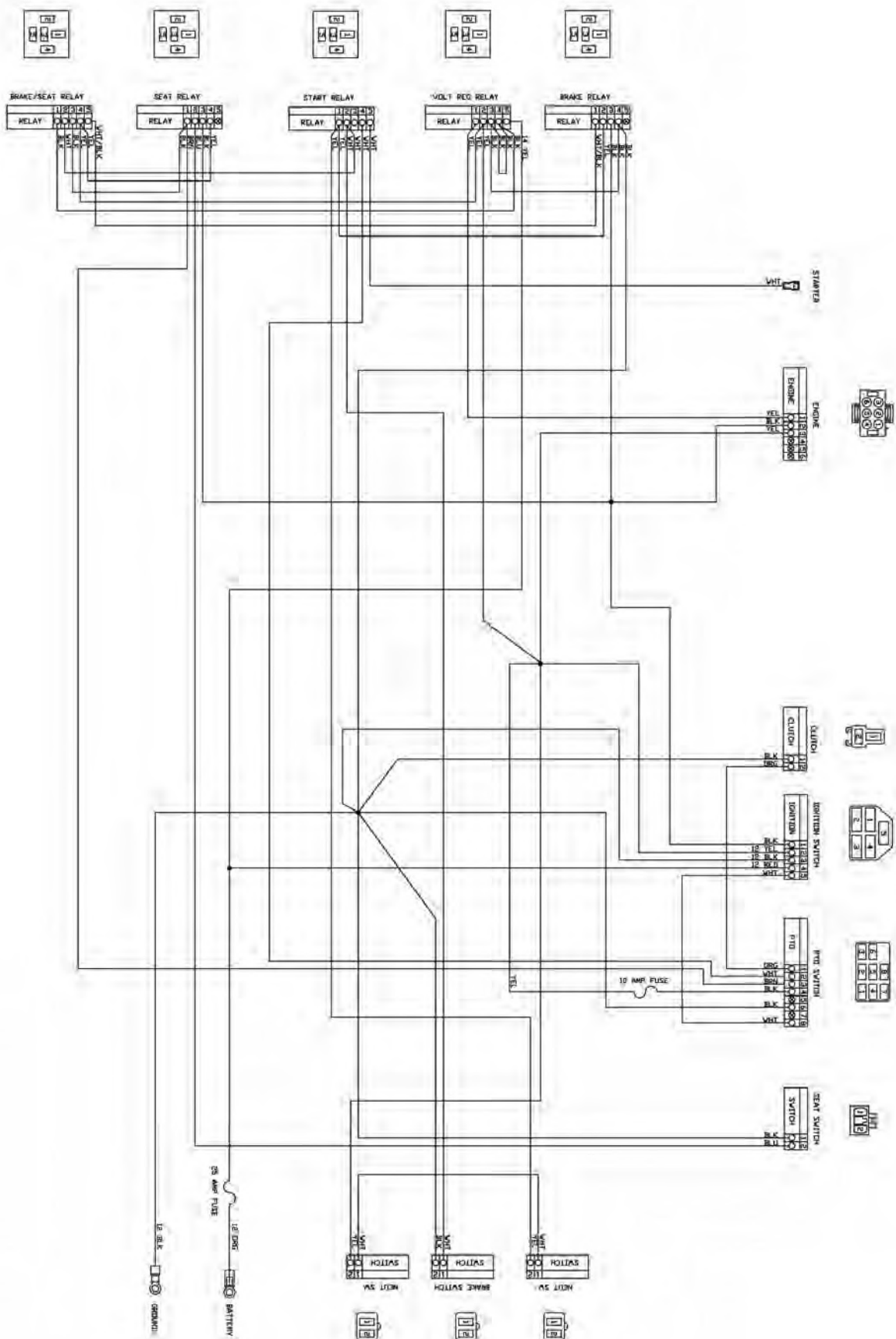

WIRE	CONTACT
1	1
2	2
3	3
4	4
5	5
6	6
7	7
8	8
9	9
10	10
11	11
12	12
13	13
14	14
15	15
16	16
17	17
18	18
19	19
20	20
21	21
22	22
23	23
24	24
25	25
26	26
27	27
28	28
29	29
30	30
31	31
32	32
33	33
34	34
35	35
36	36
37	37
38	38
39	39
40	40
41	41
42	42
43	43
44	44
45	45
46	46
47	47
48	48
49	49
50	50

ALL WIRES LEAD UNLESS NOTED OTHERWISE





## SECTION 5: FRAME

The front fork nuts require a torque of 40ft.-lbs. While applying this torque, turn the fork itself to ensure no damage is done to the bearing. This operation is only necessary if a repair requires it. To access the recessed front fork nuts, remove the dust cap by prying gently using a flat-head screwdriver. Once cap is removed, a 36mm socket will be needed for top nut. You will need to secure the bottom nut with a 1 1/2". wrench. Once you have torqued the nuts to 40 ft.-lbs., reapply the dust cap by gently tapping around its edges. Do NOT hit center of cap.

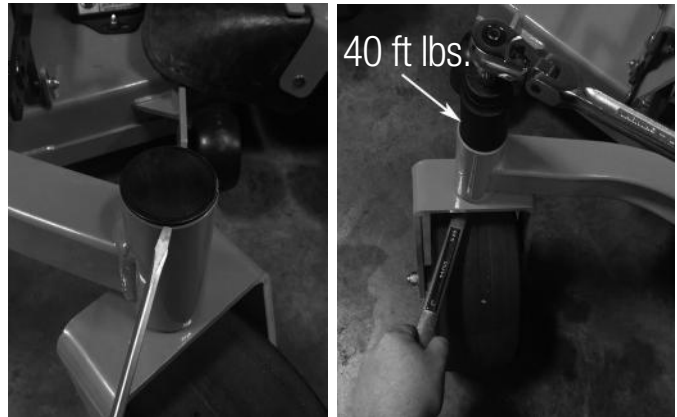

Torque rear wheel lugs to 65-75ft. lbs. Re-torque at every oil change and check every morning.



The pump belt tensioner is located under the engine and has a grease fitting at its pivot point. Grease at every engine oil change.

The deck belt tensioner is located at the rear of the deck and has a grease fitting on its pivot



The control arm blocks have grease fittings located on the top of each block. Grease one time a year.



## SECTION 6: CUTTING DECK

### Deck belt removal:

- 1) Remove ignition key.
- 2) Raise the deck to its highest position.
- 3) Remove the right pulley cover.
- 4) While lifting up on the belt (as shown in the photograph), rotate the pulley until the belt is free of the pulley. Exercise caution while performing this step as fingers can easily become caught between the belt and pulley.

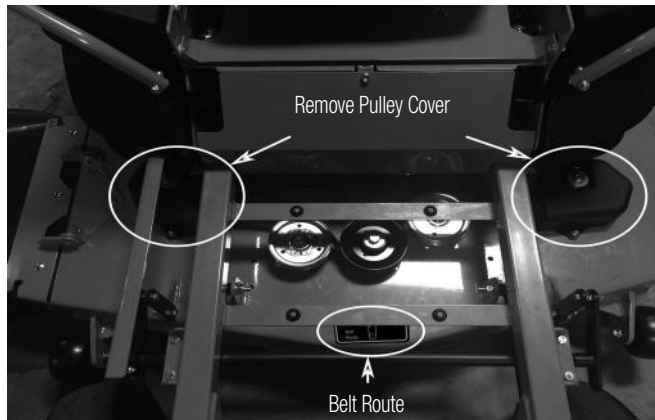

### Deck belt installation:

- 1) Follow steps 1 and 2 from the deck removal section.
- 2) Take off both pulley covers and route the belt by following the belt route sticker.
- 3) The easiest way to finish running the belt is routing the belt through the deck pulleys and carefully slipping the belt onto the clutch in the rear of the engine.
- 4) Verify that the belt is routed properly as improper routing can damage the spindles as well as the engine.

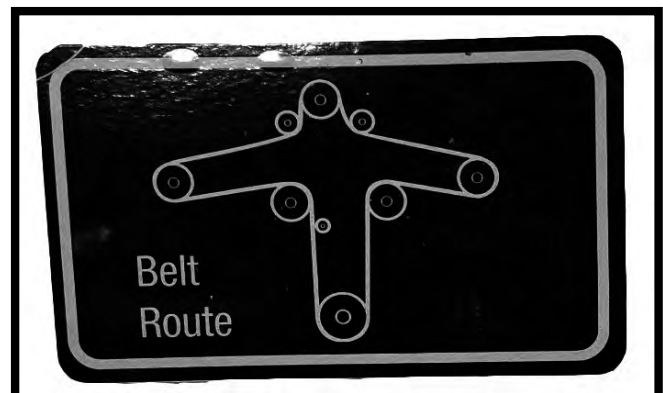
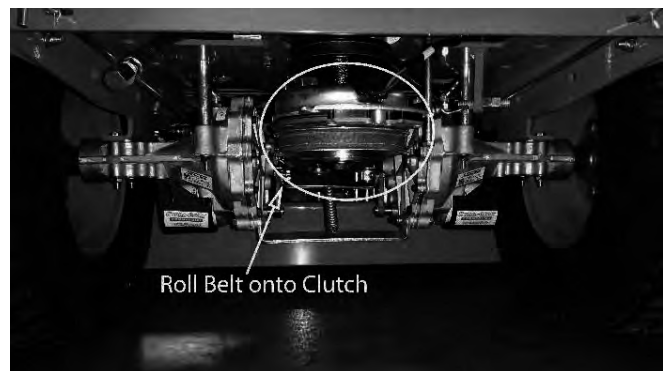



### Leveling the Deck:

- 1) Start on a flat, level surface and set the air pressure in all four tires to 12 psi.
- 2) Loosen the four bottom deck hanger bolts using a 9/16" wrench.
- 3) Using the deck adjustment foot assist pedal, raise the deck as high as it will go. Place two 2x4s, with 2" side facing up, to create 4" of space underneath the deck. Make sure the 2x4s are long enough to support both the front and back of the deck AND are away from deck wheels. Place a 1/4" spacer on each 2x4 under the REAR of the deck to obtain proper pitch.
- 4) With the deck still raised, turn the height adjustment knob to 3.5 and lower deck onto the 2x4s.
- 5) With deck still on 2x4s, tighten the four deck hanger bolts while pressing down on the deck to reduce any slack.
- 6) Remove 2x4s. Measure all four corners to ensure deck is now level. The rear should measure 4" with the front measuring 3 3/4".
- 7) Raise the deck up and ensure the height adjustment knob makes a full rotation. If full rotation is made, the deck is now level.

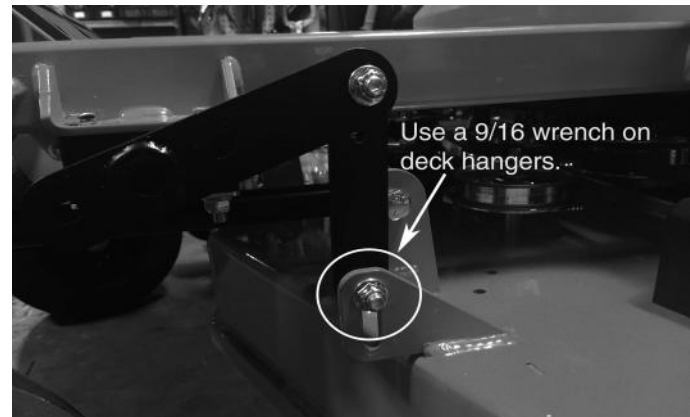

---

The deck spring tension is critical. If the tension is too high, premature failure of the deck belt and blade spindles can occur. If the tension is too low, the belt can "jump off" or slip on the pulleys. This results in reduced cut quality and early belt failure.

Spring tension adjustments can be made by sliding the bolt shown above forward or backward in the slot of the deck. Belt tension should be 60-65 lbs. with the deck at its lowest setting.

Use a belt tension gauge to ensure the proper tension. Your dealer or service center will have a belt tension gauge or you can buy one (Part Number 041-9999-00).



### Blade Shapening:

The blade on the top (see photo) was utilized long after replacement was required. In addition to a decline in cut Quality, failure to replace a worn or damaged blade creates a major safety hazard. Bad Boy recommends that blade sharpening be performed by a professional.





**Blade Removal:**

To change blades, it may be easier to use a piece of wood to keep the blade from turning so that the bolt can be loosened. Use a 15/16" socket and impact drill, or a wrench and an extension to gain more leverage. You might need to put a 3/4" wrench on top of the pulley bolt to keep the blade from spinning. **Bolts used have right-handed threads.**

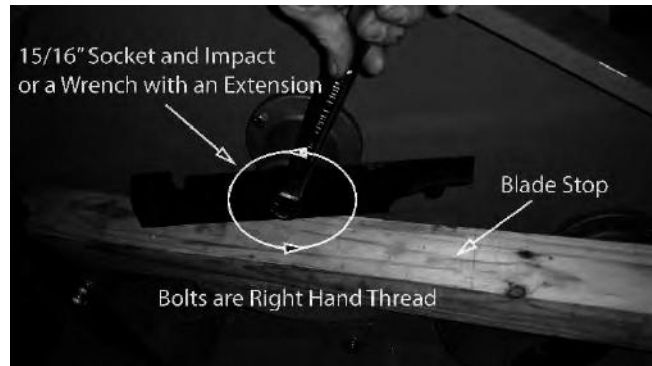

Re-torque the blade bolts to 90-110 lbs.

The blade spindles contain a sealed ball bearing inside the top and bottom of the spindle. The bearings are replaceable for a more cost effective repair.

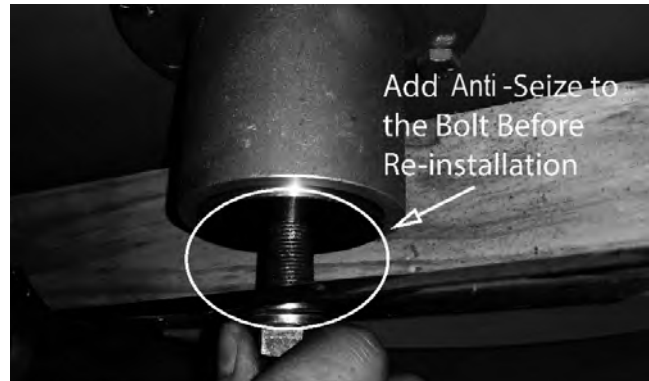

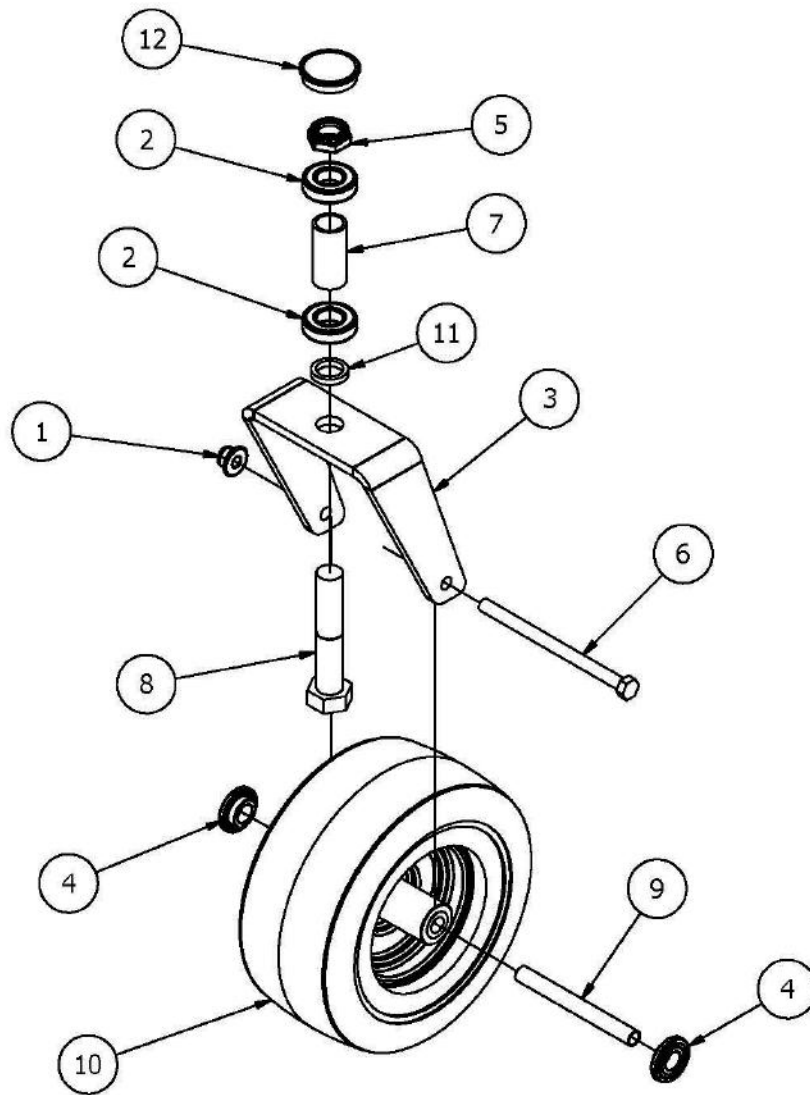

Parts List			
ITEM	QTY	PART NUMBER	DESCRIPTION
1	1	013-8050-00	1/2-13 Nylon Flange Nut
2	2	010-1050-00	Caster Bearing 2016 - 1641 Bearing
3	1	023-0002-00	2017 MZ Front fork
4	2	022-7009-00	Wheel Bearing
5	1	013-9004-00	1" Fine Thread Nut
6	1	018-0035-00	1/2 -13 x 7.5 Hex Bolt Grade 5
7	1	025-0003-00	2016 Front Bearing Spacer
8	1	018-0005-00	1-14 x 5 Hex Bolt Grade 8 Zinc Yellow
9	1	025-0008-00	Front Wheel Spanner
10	1	022-8049-00	11x6-5 front tire & wheel assembly
11	1	058-1000-00	1" x .25" Spacer
12	1	014-2025-00	2017 Bearing Cover



MZ Arm Assembly

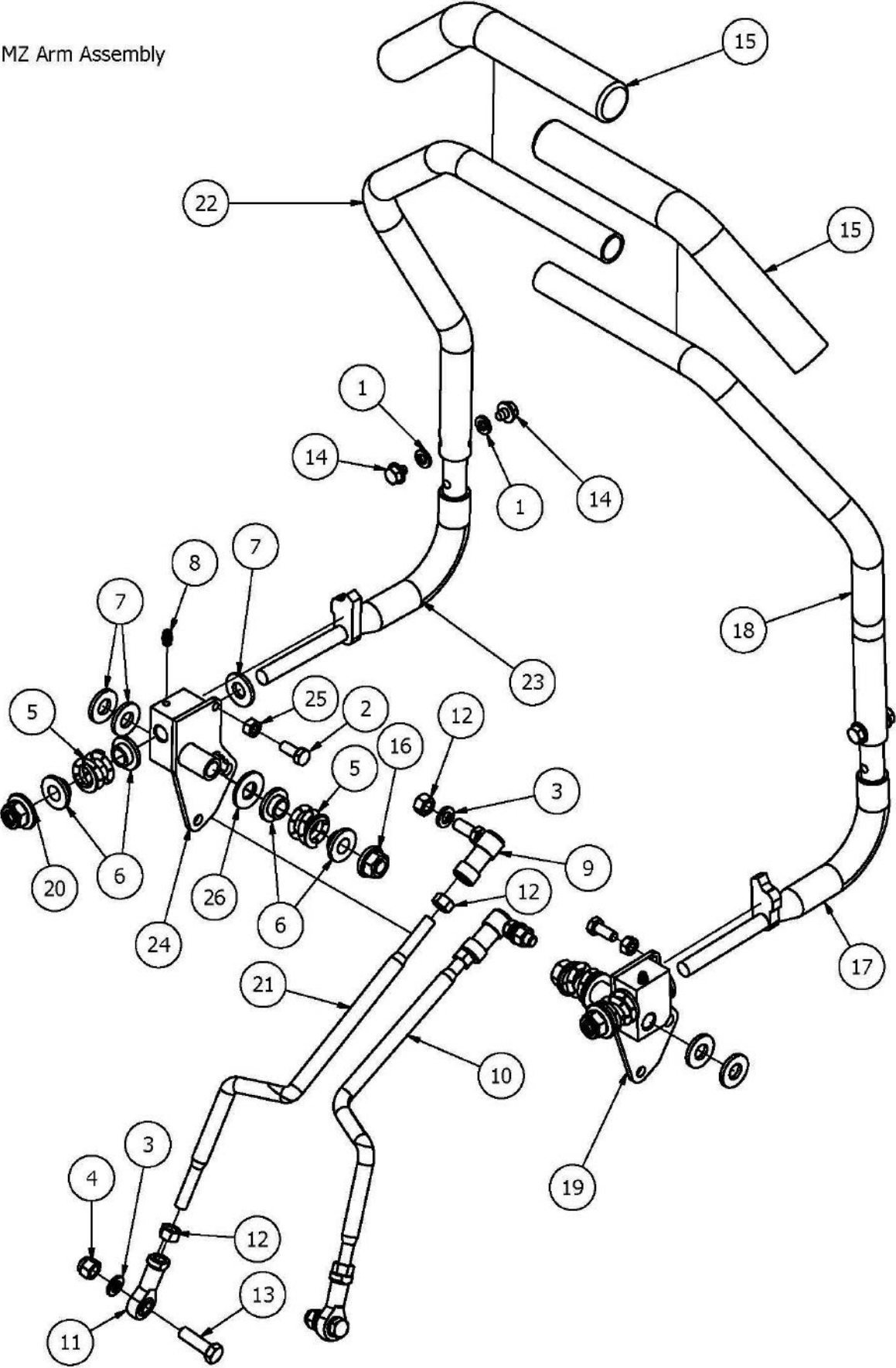

Parts List			
ITEM	QTY	PART NUMBER	DESCRIPTION
1	4	019-8051-00	5/16" Lock Washer
2	2	018-8063-00	5/16" x 3/4" Hex Bolt
3	4	019-5037-00	3/8" Lock Washer
4	2	013-5041-00	3/8 Nylock Nut
5	4	034-8025-00	Drive Lever Spring
6	8	019-8027-00	.515 ID Nylon Shoulder Washer
7	6	019-8054-00	.505 Nylon Spacer
8	2	024-6034-00	1/4 Drive-In Grease Fitting
9	2	099-2009-00	3/8-24 Quick Release Ball Joint
10	1	035-5450-00	Push Rod - Right
11	2	048-3000-00	Spherical Rod End - Outlaw
12	6	013-6051-00	3/8" Fine Threaded Jam Nut
13	2	018-5040-00	3/8" x 1 1/4" Hex Bolt
14	4	018-2020-00	5/16-18 1/2 HWH Bolt-Steering
15	2	069-4007-00	Rubber Grip
16	2	013-0085-00	1/2-13 Hex Flange (GR.G) ZC
17	1	031-9025-70	Steering Arm Elbow - Right
18	1	031-8851-00	ZT Direction Steering Arm (Right)
19	1	031-0018-98	2017 Drive Lever Housing - Right
20	2	013-8050-00	1/2-13 Nylon Flange Nut
21	1	035-5451-00	Push Rod - Left
22	1	031-8850-00	ZT Direction Steering Arm (Left)
23	1	031-9020-70	Steering Arm Elbow - Left
24	1	031-0017-98	2017 Drive Lever Housing - Left
25	2	013-8043-00	5/16" Nut
26	2	019-5702-00	1/2" Washer (Grade 8)





MZ Gas Tank Assembly

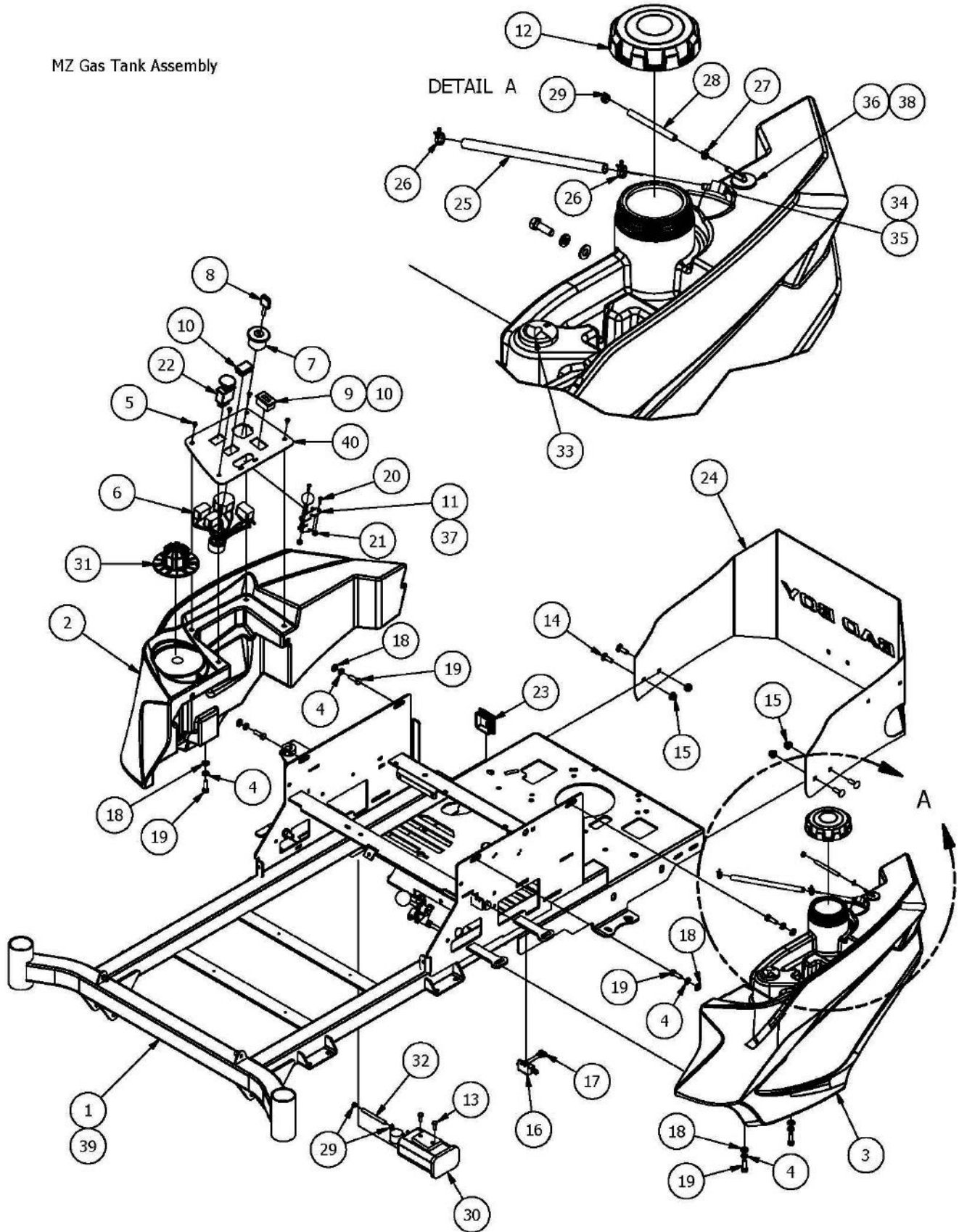

Parts List			
ITEM	QTY	PART NUMBER	DESCRIPTION
1	1	070-5810-00	2017 MZ/ZT 42"-48" Frame
2	1	067-2080-50	2017 MZ Right Gas Tank
3	1	067-2090-50	2017 MZ Left Gas Tank
4	7	019-8051-00	5/16" Lock Washer
5	4	018-2010-00	10-32 x 3/8" Button Socket Head Bolt
6	1	086-3050-17	Universal Wire Harness
7	1	077-8076-00	Ignition Switch
8	1	042-9000-00	Ignition Key
9	1	083-4013-00	Tachometer (MZ Magnum only)
10	2	018-1040-00	Plug
11	1	055-3000-00	Throttle Lever
12	1	066-8083-00	Fuel Cap
13	2	018-0024-00	M6-1.0 X 16MM Hex Bolt
14	4	018-8065-00	5/16" x 1" Carriage Bolt
15	4	013-8049-00	5/16"-18 Nylon Flange Nut
16	2	077-8073-00	Safety Switch
17	4	018-1080-00	12-24x 1/2 HWH Bolt
18	7	019-8044-00	5/16" Flat Washer
19	7	018-2007-00	5/16" x 1" Bolt
20	2	018-5200-00	10-24 x 5/8 Button Head Bolt
21	2	013-5019-00	10-24 Nylon Insert Locknut
22	1	056-8058-00	PTO Switch
23	2	014-9000-00	2x2 Square Plug
24	1	026-0117-00	2017 MZ Rear Plate
25	1	051-8067-00	1/4" Fuel Line Hose
26	2	072-8069-00	1/4 Fuel Hose Clamp
27	1	072-8073-00	3/16" Vinyl Hose Clamp
28	1	051-2027-00	3/16" Clear Vinyl Tubing
29	3	072-8070-00	3/16 Vinyl Clamp
30	1	067-0015-00	Carbon Canister for Magnum/MZ
31	1	077-9000-00	MZ/ZT Deck Height Dial
32	1	051-8073-00	3/16 Vinyl Tubing
33	1	067-4080-00	Fuel Guage with Grommet
34	1	067-6080-00	Pick Up Grommet
35	1	067-0011-00	Pick Up Grommet
36	1	067-6050-00	Rollover Valve
37	1	055-3021-00	Throttle MZ (Briggs Only)
38	1	067-6070-00	Rollover Valve Grommet
39	1	070-5420-00	MZ Magnum Frame
40	1	079-3460-00	Control Panel



MZ Frame Top Assembly

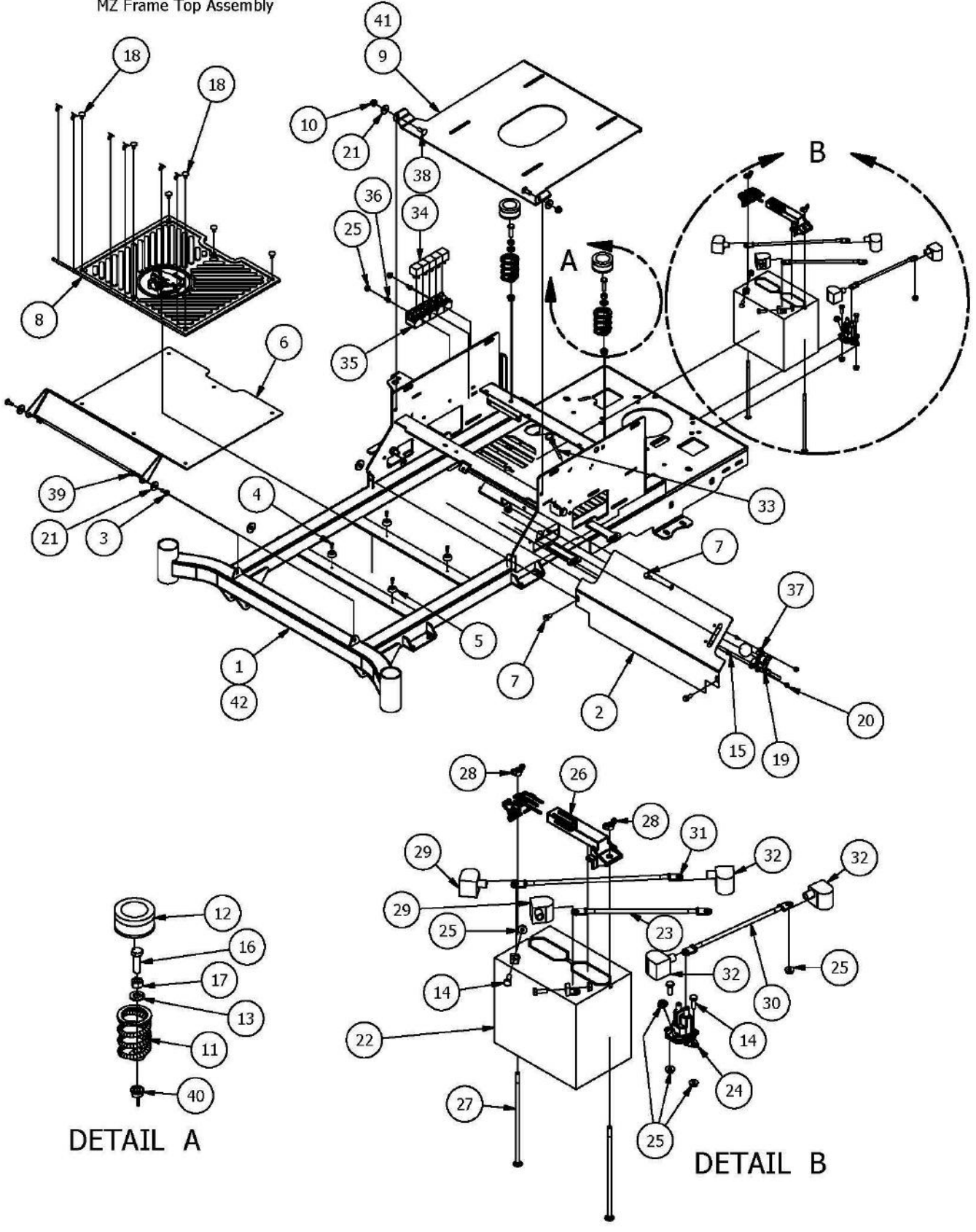

Parts List			
ITEM	QTY	PART NUMBER	DESCRIPTION
1	1	070-5810-00	2017 MZ/ZT 42"-48" Frame
2	1	014-3317-00	2017 MZ Cooler Cover
3	2	019-8040-00	1/4" x 3/4" Carriage Bolt
4	4	030-3050-00	#10 x 1/2" Self Tapping Screw
5	4	029-4010-00	Button Bumper
6	1	079-3417-00	MZ/ZT 2017 Floorboard
7	3	030-7042-00	5/16 x 3/4 washer head type F screw
8	1	081-4000-00	2017 MZ/ZT Floor Mat
9	1	026-2017-00	2017 MZ Seat Plate
10	2	013-8049-00	5/16-18 Nylon Flange Nut
11	2	034-8045-00	Seat Spring
12	2	014-8047-00	Seat Spring Cap Cover
13	2	019-5029-00	3/8" Flat Washer
14	4	018-8052-00	1/4" x 3/4" Hex Bolt
15	2	018-5200-00	10-24 x 5/8 Button Head Bolt
16	2	018-3000-00	3/8" x2" Hex Bolt
17	2	013-6014-00	3/8-16 Hex Nuts Zinc
18	12	040-6090-00	5/8" Christmas Tree Fastener
19	1	064-8057-17	MZ Brake Cable
20	2	013-5019-00	10-24 Nylon Insert Locknut
21	4	019-6042-00	.360ID Plastic Washer
22	1	068-8049-00	Battery
23	1	064-0030-00	Ground Cable
24	1	108-5349-00	Solenoid
25	6	013-9001-00	1/4-20 Hex Flange Nuts Zinc w/Serrations
26	1	043-8929-00	Battery Hold Down
27	2	018-8050-00	1/4-20 X 8 Carriage Bolt
28	2	013-8051-00	1/4" Wing Nut
29	2	103-5400-00	Black Boot For Ground Cable
30	1	064-5301-00	12 in red battery cable
31	1	064-5300-00	24" Red Battery Cable
32	3	103-5300-00	Red Boot
33	1	054-8017-00	Choke
34	5	086-1201-00	Relay
35	1	086-3050-17	Harness
36	2	018-2012-00	1/4" x 1/2" BS C/S 18-8 SS
37	1	055-2012-00	Universal Throttle
38	2	018-8066-00	5/16" x 7/8" Carriage Bolt
39	2	013-2050-00	1/4-20 Nylon Insert flange Nut
40	2	013-5201-00	3/8" Flange Nut
41	1	026-1016-00	Magnum Seat Pan (Kawasaki Only)
42	1	070-5420-00	Magnum Frame



## MZ & Magnum Seat

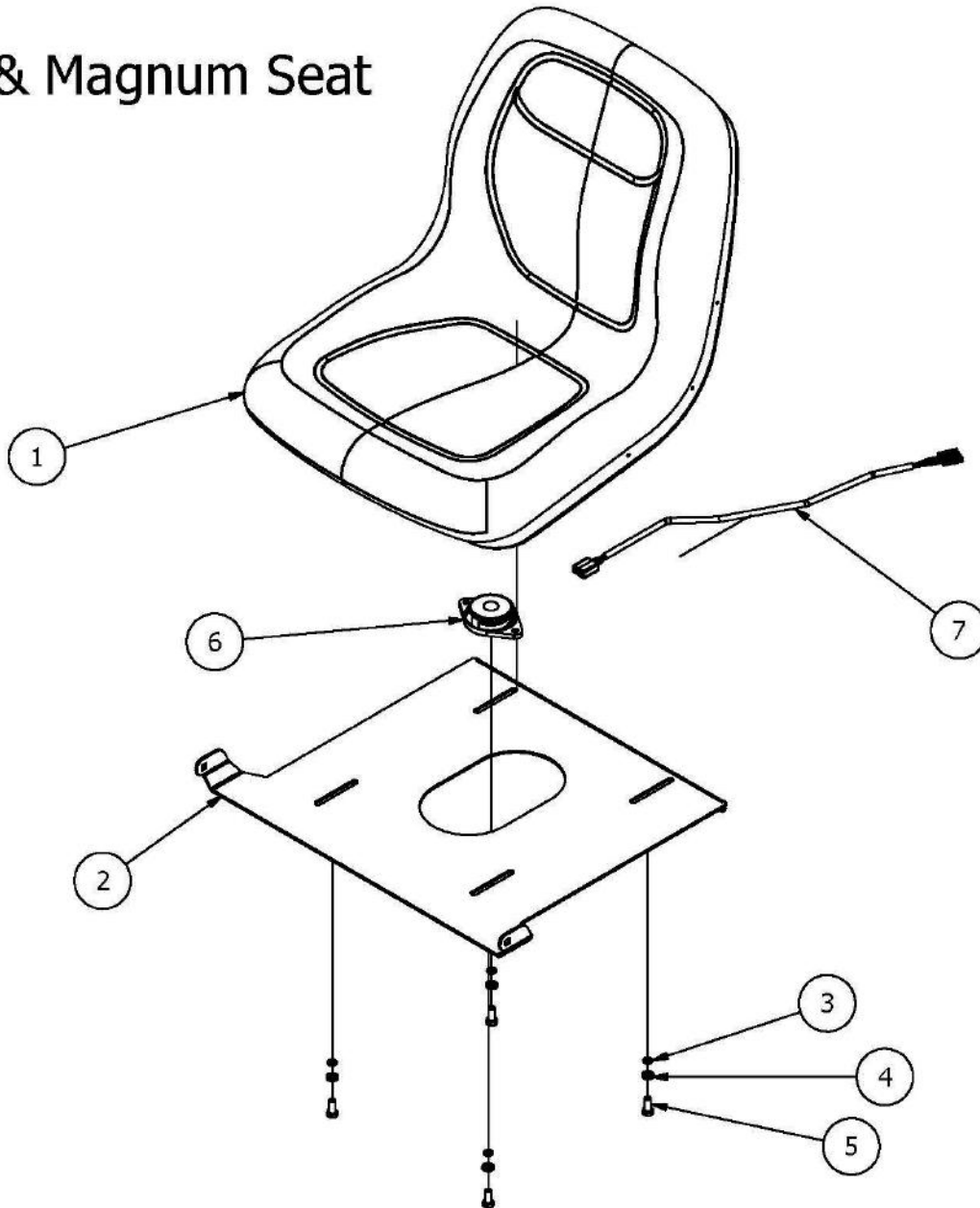

Parts List			
ITEM	QTY	PART NUMBER	DESCRIPTION
1	1	071-9001-00	MZ Seat
2	1	026-2017-00	2017 MZ Seat Plate
3	4	019-7040-00	1/4 Flat Washer
4	4	019-8051-00	5/16" Lock Washer
5	4	018-8063-00	5/16" x 3/4" Hex Bolt
6	1	071-8062-00	SeatSafetySwitch
7	1	036-5300-00	Seat Switch Adapter

## MZ Magnum Seat Page for Kawasaki Magnum ONLY

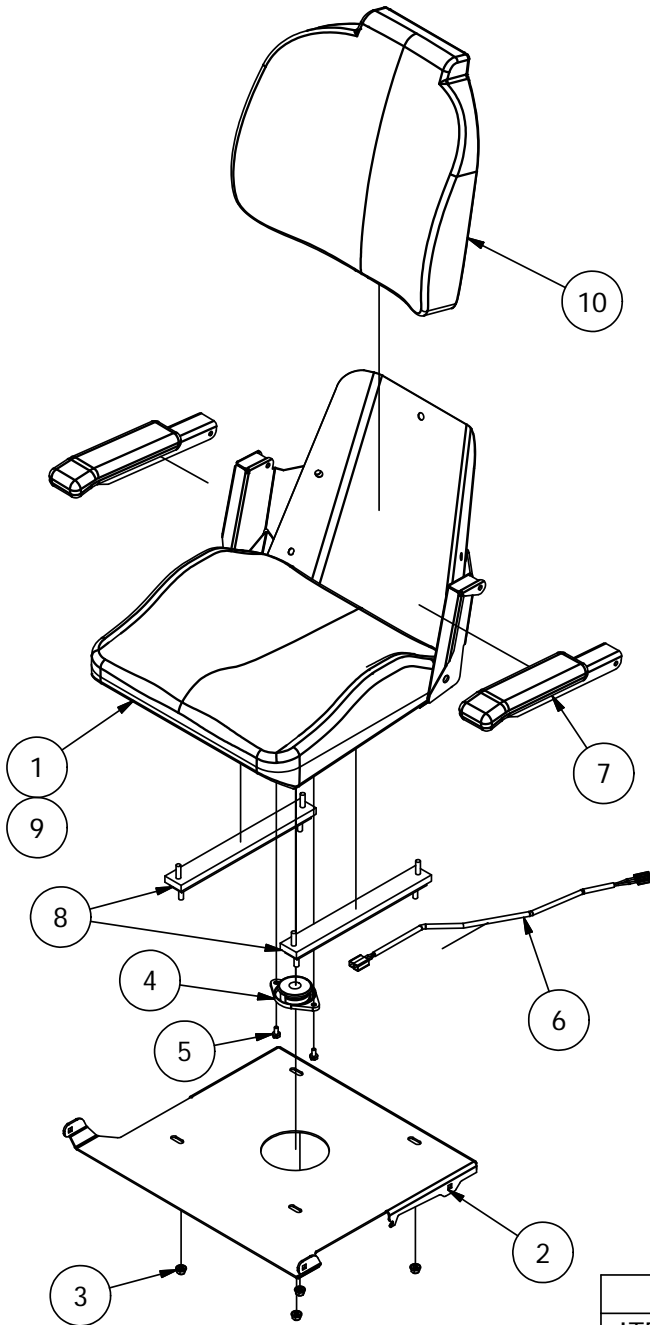

Parts List

ITEM	QTY	PART NUMBER	DESCRIPTION
1	1	071-2040-00	2017 Zt Seat
2	1	026-1016-00	Seat Plate 2016
3	4	013-8049-00	5/16" Nylon Flange Nut
4	1	071-8061-00	Seat Safety Switch
5	2	030-7041-00	1/4-20x1/2 HWH Bolt Slot
6	1	036-5300-00	Seat Switch Adapter
7	2	071-2017-00	Arm Rest
8	1	071-2020-50	Seat Rail Pair
9	1	071-2019-00	Seat Bottom Cushion
10	1	071-2014-16	Seat Back Cushion
11	1	071-2013-00	Seat Belt Kit (Not Shown)



# MZ Frame Bottom

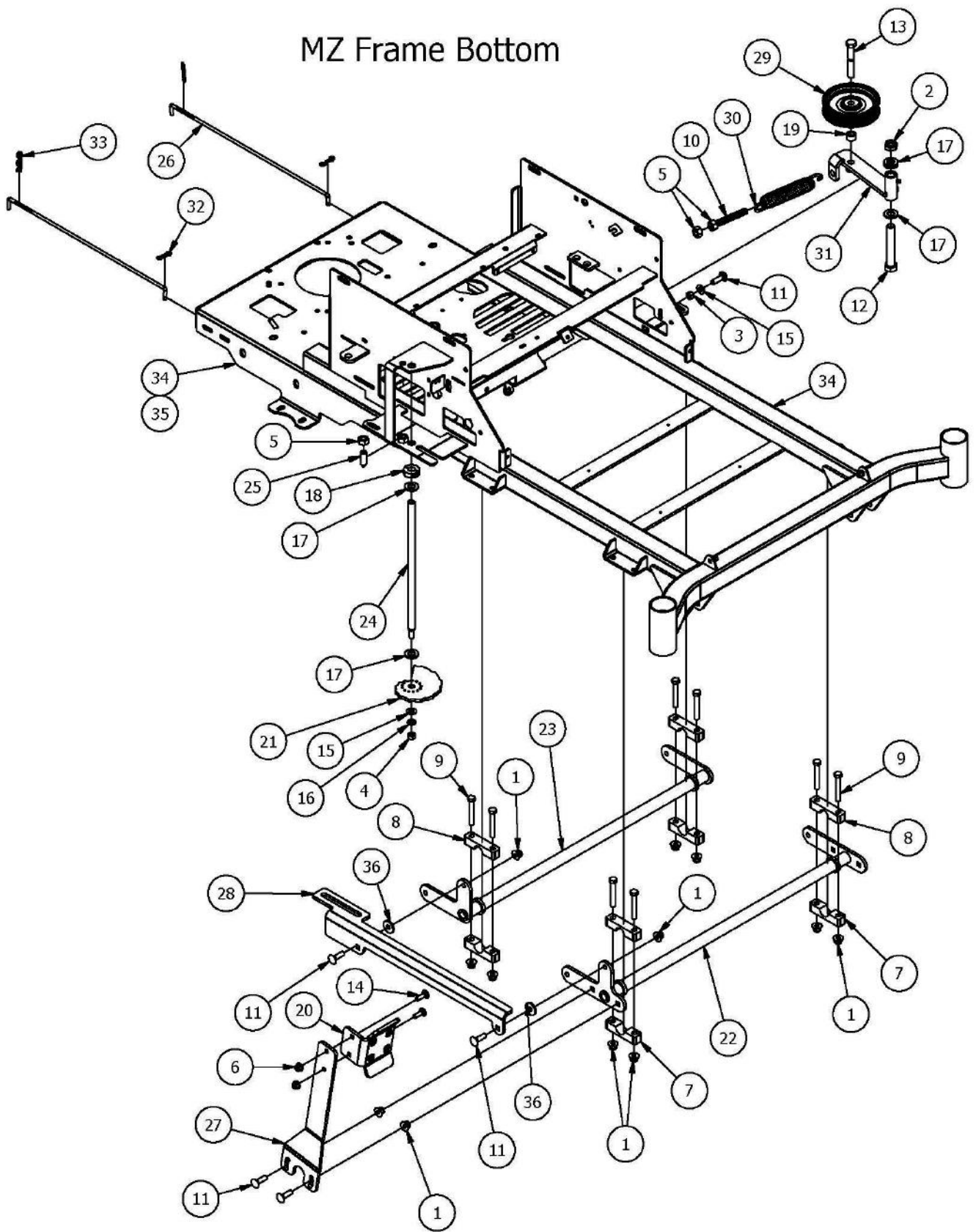

Parts List			
ITEM	QTY	PART NUMBER	DESCRIPTION
1	12	013-5202-00	3/8 Nylock Flange Nut
2	1	013-5301-00	5/8" Nylock (1/2 Jam)
3	2	013-6014-00	3/8-16 Hex Nut Zinc
4	1	013-6051-00	3/8" Fine Threaded Jam Nut
5	3	013-7018-00	1/2" Hex Nut
6	2	013-8049-00	5/16" Nylon Flange Nut
7	4	017-9077-00	Pillow Block MZ male
8	4	017-9078-00	Pillow Block MZ female
9	8	018-0028-00	3/8 x 2 1/2" Hex Bolt
10	1	018-2004-50	All Thread-Pump Idler Tensioner
11	6	018-5043-00	3/8" x 1 1/4" Carriage Bolt
12	1	018-5311-00	5/8" x 4" Hex Bolt
13	1	018-6036-00	1/2 x 2-3/4 Hex Bolt
14	2	018-8065-00	5/16" x 1" Carriage Bolt
15	3	019-5029-00	3/8" Flat Washer
16	1	019-5037-00	3/8" Lock Washer
17	4	019-6017-00	.630 ID Plastic Washer
18	1	025-0002-00	5/8" Split Collar
19	1	025-7036-00	1/2 Set Collar W/Set Screw
20	1	026-0019-00	2017 MZ/ZT Shallow Foot Pedal
21	1	026-1100-00	2017 MZ/ZT Cam Plate
22	1	028-0002-00	Actuator Bar Front- 2017 MZ/ZT
23	1	028-0003-00	Actuator Bar Rear- 2017 MZ/ZT
24	1	028-0007-00	2017 Deck Height Dial Rod MZ
25	1	028-0008-00	Dial Rod Plunger
26	2	028-0070-00	Neutral Rod
27	1	031-0500-00	2017 MZ/ZT Deck Pedal Lever
28	1	031-0510-00	2017 MZ/ZT Actuator Linkage
29	1	033-6001-00	4 3/4" Idler Pulley
30	1	034-2020-00	2015 Deck Idler Spring
31	1	039-5944-00	Pump Idler Bracket
32	2	044-2004-00	Bow Pin
33	2	044-2008-00	Neutral Rod Clip
34	1	070-5810-00	2017 MZ 42"-48" Frame
35	1	070-5420-00	2017 54" Magnum Frame
36	2	019-2073-00	.390 ID Plastic Washer





# Kohler KT-725 & KT-740

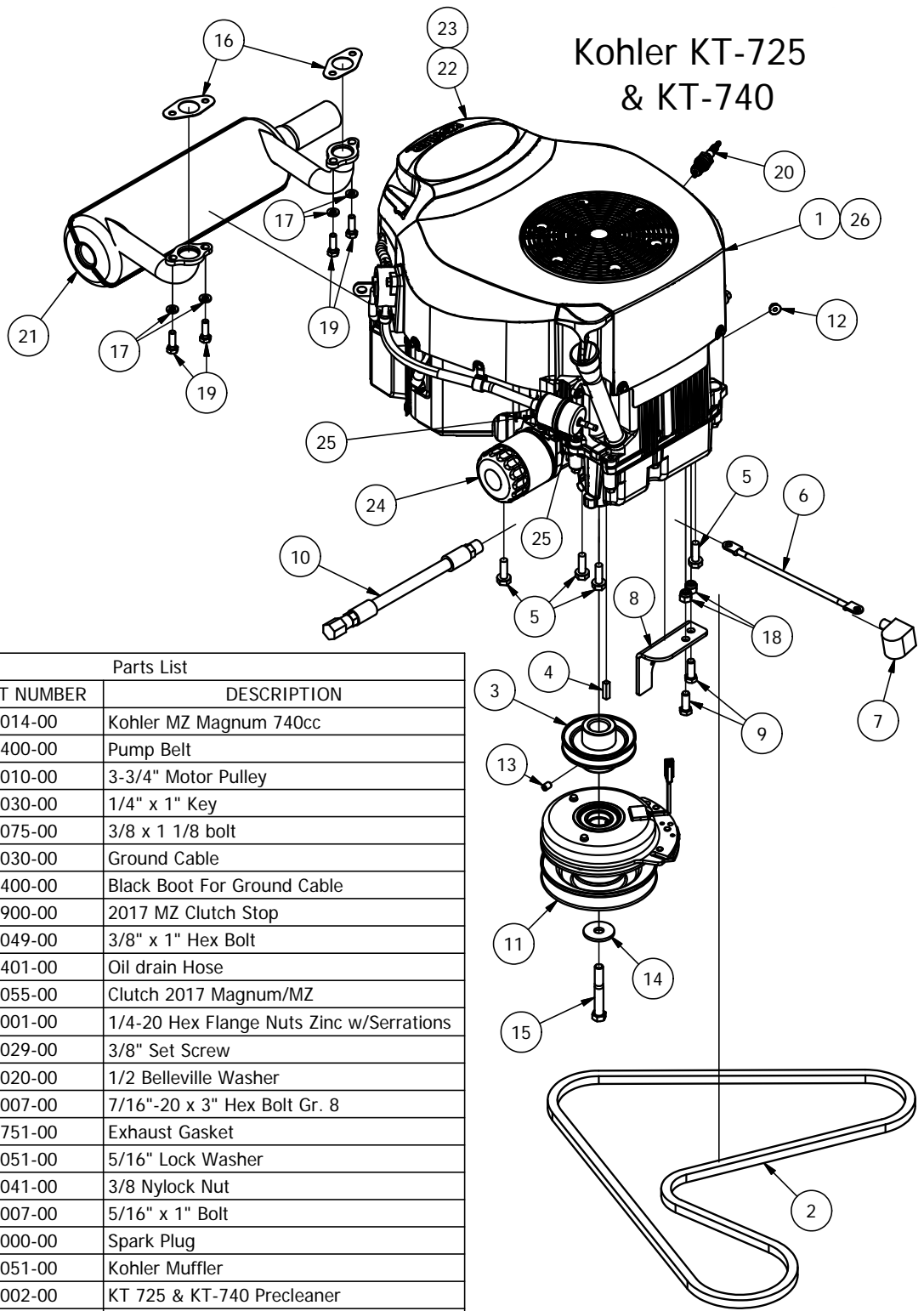

Parts List			
ITEM	QTY	PART NUMBER	DESCRIPTION
1	1	015-2014-00	Kohler MZ Magnum 740cc
2	1	041-6400-00	Pump Belt
3	1	033-2010-00	3-3/4" Motor Pulley
4	1	042-6030-00	1/4" x 1" Key
5	4	018-1075-00	3/8 x 1 1/8 bolt
6	1	064-0030-00	Ground Cable
7	1	103-5400-00	Black Boot For Ground Cable
8	1	057-5900-00	2017 MZ Clutch Stop
9	2	018-6049-00	3/8" x 1" Hex Bolt
10	1	051-5401-00	Oil drain Hose
11	1	070-0055-00	Clutch 2017 Magnum/MZ
12	1	013-9001-00	1/4-20 Hex Flange Nuts Zinc w/Serrations
13	1	030-6029-00	3/8" Set Screw
14	1	019-6020-00	1/2 Belleville Washer
15	1	018-0007-00	7/16"-20 x 3" Hex Bolt Gr. 8
16	2	015-2751-00	Exhaust Gasket
17	4	019-8051-00	5/16" Lock Washer
18	2	013-5041-00	3/8 Nylock Nut
19	4	018-2007-00	5/16" x 1" Bolt
20	1	015-8000-00	Spark Plug
21	1	015-0051-00	Kohler Muffler
22	1	063-5002-00	KT 725 & KT-740 Precleaner
23	1	063-5003-00	KT 725 & KT-740 Air Element
24	1	063-5400-00	KT 725 & KT-740 Oil Filter
25	1	063-6000-00	Universal Fuel Filter
26	1	015-2015-00	Kohler KT- 725

# 540CC Briggs Engine

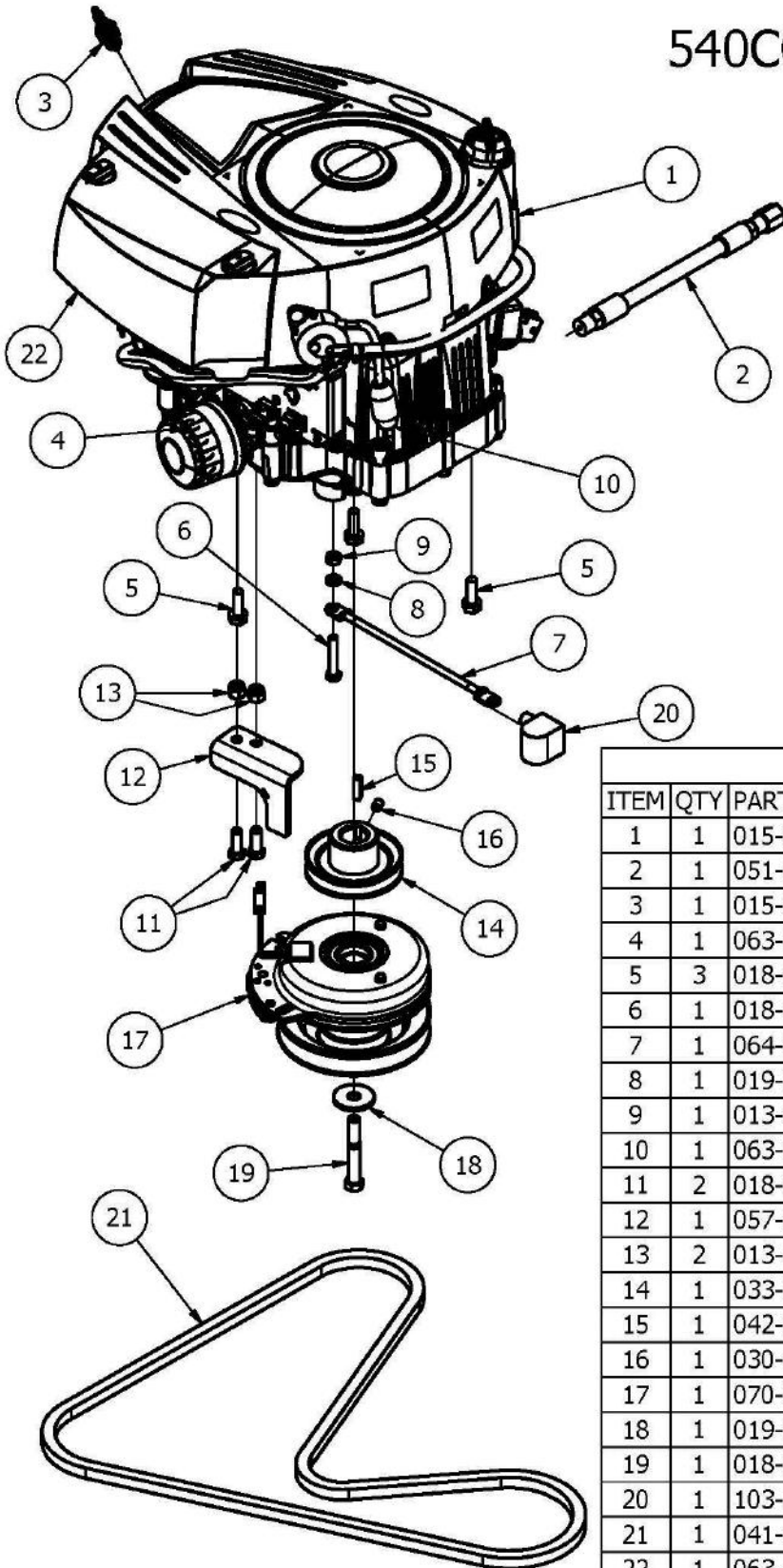

Parts List

ITEM	QTY	PART NUMBER	DESCRIPTION
1	1	015-0021-00	540cc Briggs Intek Engine-MZ
2	1	051-5401-00	Oil drain Hose
3	1	015-8000-00	Spark Plug
4	1	063-8018-00	Briggs Oil Filter
5	3	018-1075-00	3/8 x 1 1/8 bolt
6	1	018-8059-00	5/16" x 1 3/4" Hex Bolt
7	1	064-0030-00	Ground Cable
8	1	019-8051-00	5/16" Lock Washer
9	1	013-8043-00	5/16" Nut
10	1	063-6000-00	Universal Inline Fuel Filter
11	2	018-6049-00	3/8" x 1" Hex Bolt
12	1	057-5900-00	2017 MZ Clutch Stop
13	2	013-5041-00	3/8 Nylock Nut
14	1	033-2010-00	3-3/4" Motor Pulley
15	1	042-6030-00	1/4" x 1" Key
16	1	030-6029-00	3/8" Set Screw
17	1	070-0055-00	Clutch 2017 Magnum/MZ
18	1	019-6020-00	1/2 Belleville Washer
19	1	018-0007-00	7/16"-20 x 3" Hex Bolt Gr. 8
20	1	103-5400-00	Black Boot For Ground Cable
21	1	041-6400-00	Pump Belt
22	1	063-4026-00	Air Filter



## Kawasaki FR-651V

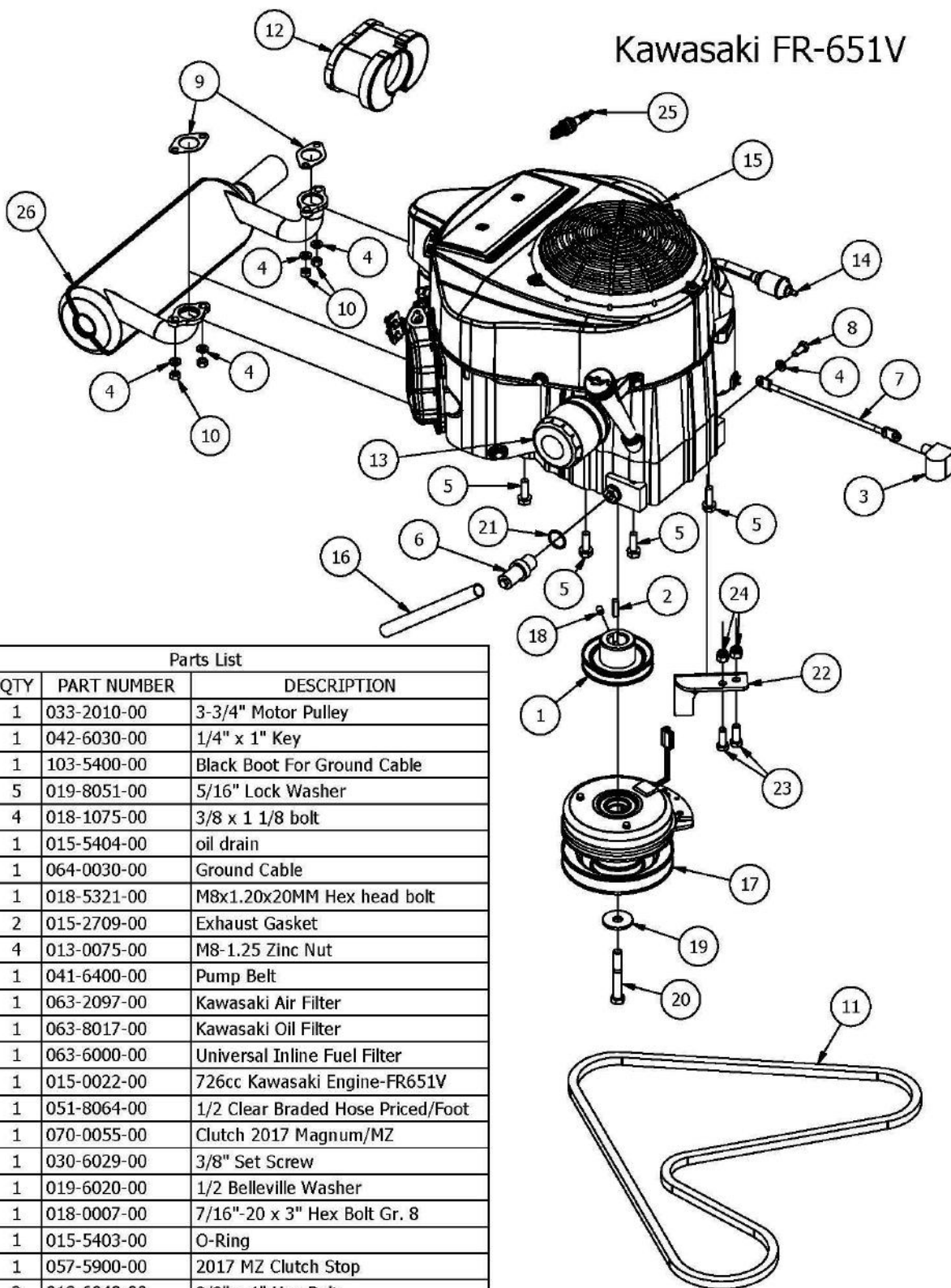

Parts List

ITEM	QTY	PART NUMBER	DESCRIPTION
1	1	033-2010-00	3-3/4" Motor Pulley
2	1	042-6030-00	1/4" x 1" Key
3	1	103-5400-00	Black Boot For Ground Cable
4	5	019-8051-00	5/16" Lock Washer
5	4	018-1075-00	3/8 x 1 1/8 bolt
6	1	015-5404-00	oil drain
7	1	064-0030-00	Ground Cable
8	1	018-5321-00	M8x1.20x20MM Hex head bolt
9	2	015-2709-00	Exhaust Gasket
10	4	013-0075-00	M8-1.25 Zinc Nut
11	1	041-6400-00	Pump Belt
12	1	063-2097-00	Kawasaki Air Filter
13	1	063-8017-00	Kawasaki Oil Filter
14	1	063-6000-00	Universal Inline Fuel Filter
15	1	015-0022-00	726cc Kawasaki Engine-FR651V
16	1	051-8064-00	1/2 Clear Braded Hose Priced/Foot
17	1	070-0055-00	Clutch 2017 Magnum/MZ
18	1	030-6029-00	3/8" Set Screw
19	1	019-6020-00	1/2 Belleville Washer
20	1	018-0007-00	7/16"-20 x 3" Hex Bolt Gr. 8
21	1	015-5403-00	O-Ring
22	1	057-5900-00	2017 MZ Clutch Stop
23	2	018-6049-00	3/8" x 1" Hex Bolt
24	2	013-5041-00	3/8 Nylock Nut
25	1	015-8001-00	Spark Plug - Kawasaki
26	1	015-0052-00	Kawasaki Muffer 1251

# MZ Transaxle

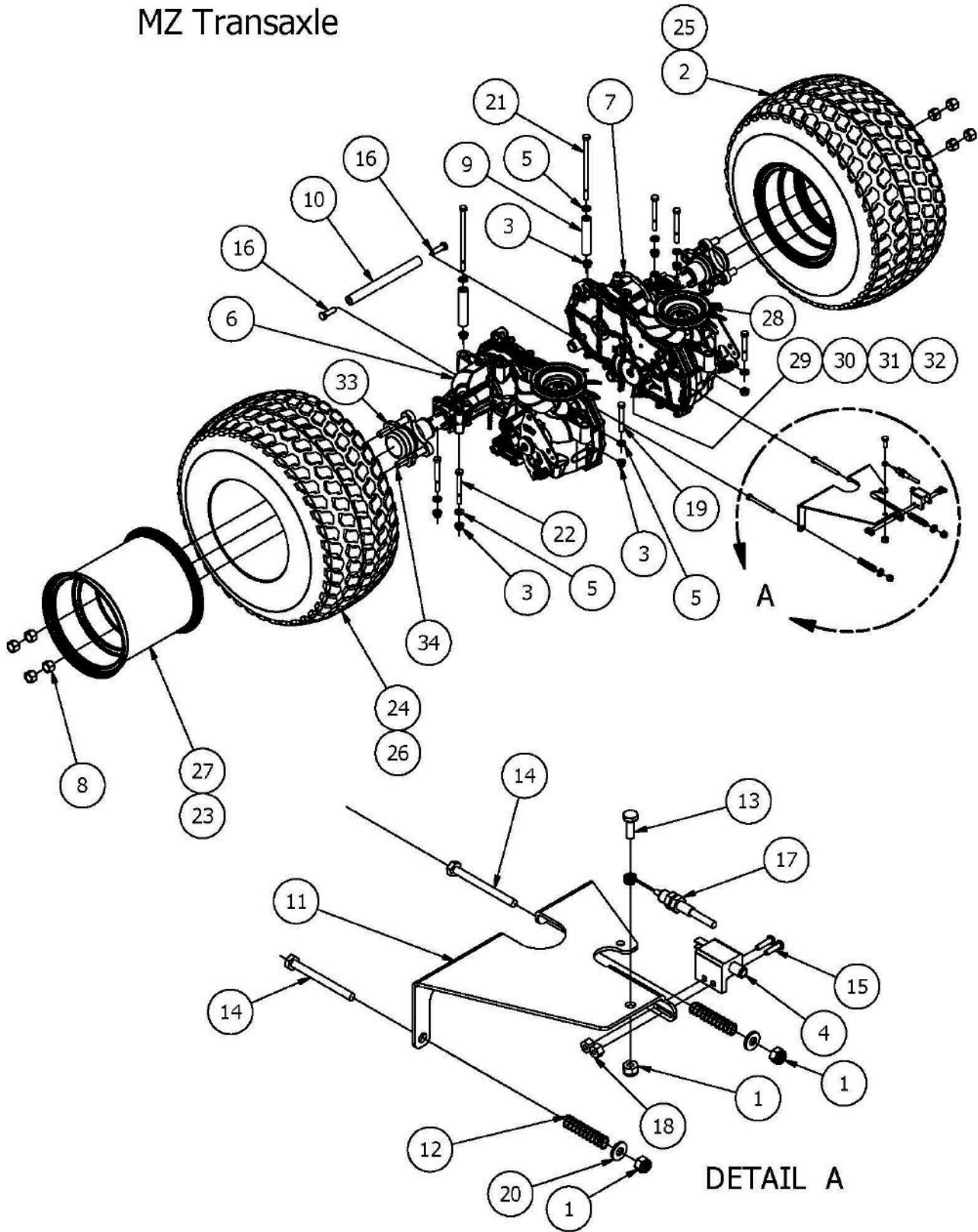



Parts List			
ITEM	QTY	PART NUMBER	DESCRIPTION
1	3	013-8073-00	1/4 Nylock Nut
2	2	022-8050-00	18x9.50-8 48 and 54 mz only
3	8	013-8049-00	5/16" Nylon Flange Nut
4	1	077-8073-00	Safety Switch
5	8	019-8044-00	5/16" Flat Washer
6	1	050-4070-00	2017 MZ Right Transaxle
7	1	050-4071-00	2017 MZ Left Transaxle
8	8	013-3000-00	Acorn Lug Nut
9	2	025-0070-00	2017 Transaxle Spacer
10	1	025-0016-00	2017 Transaxle Spacer-MZ
11	1	039-0035-00	2017 MZ Brake Lock Bracket
12	2	034-3050-00	Brake Spring
13	1	018-8052-00	1/4" x 3/4" Hex Bolt
14	2	018-1076-00	1/4-20 x2-1/2 Gr2 hex C/s zinc
15	2	018-5200-00	10-24 X 5/8 Button Head Bolt
16	2	018-3000-00	3/8" x2" Hex Bolt
17	1	064-8057-17	2017 MZ Brake Cable
18	2	013-5019-00	10-24 Nylon Insert Locknut
19	2	018-5344-00	5/16 x 2 1/2 Bolt
20	2	019-7040-00	1/4" Flat Washer
21	2	018-5355-00	5/16" x 6" Bolt
22	4	018-4701-00	5/16" x 3" Hex Bolt
23	2	022-2055-17	42 MZ Wheel
24	2	022-8027-00	42 MZ Tire
25	2	022-2050-17	42 MZ Wheel & Tire Assembly 18x8.50-8
26	2	022-8025-00	48 & 54 MZ Tire
27	2	022-8026-00	48 & 54 MZ Wheel
28	2	050-2075-00	MZ Fan & Pully Kit
29	2	050-4032-98	MZ Brake Cog Kit
30	2	050-4033-00	MZ Retainer Ring for Brake
31	2	050-4034-00	MZ Brake Gear
32	2	050-4035-00	MZ Brake Arm Kit
33	2	050-2078-00	MZ Hub Kit
34	8	050-2012-00	Transaxle Wheel Studs

# MZ 42" Deck

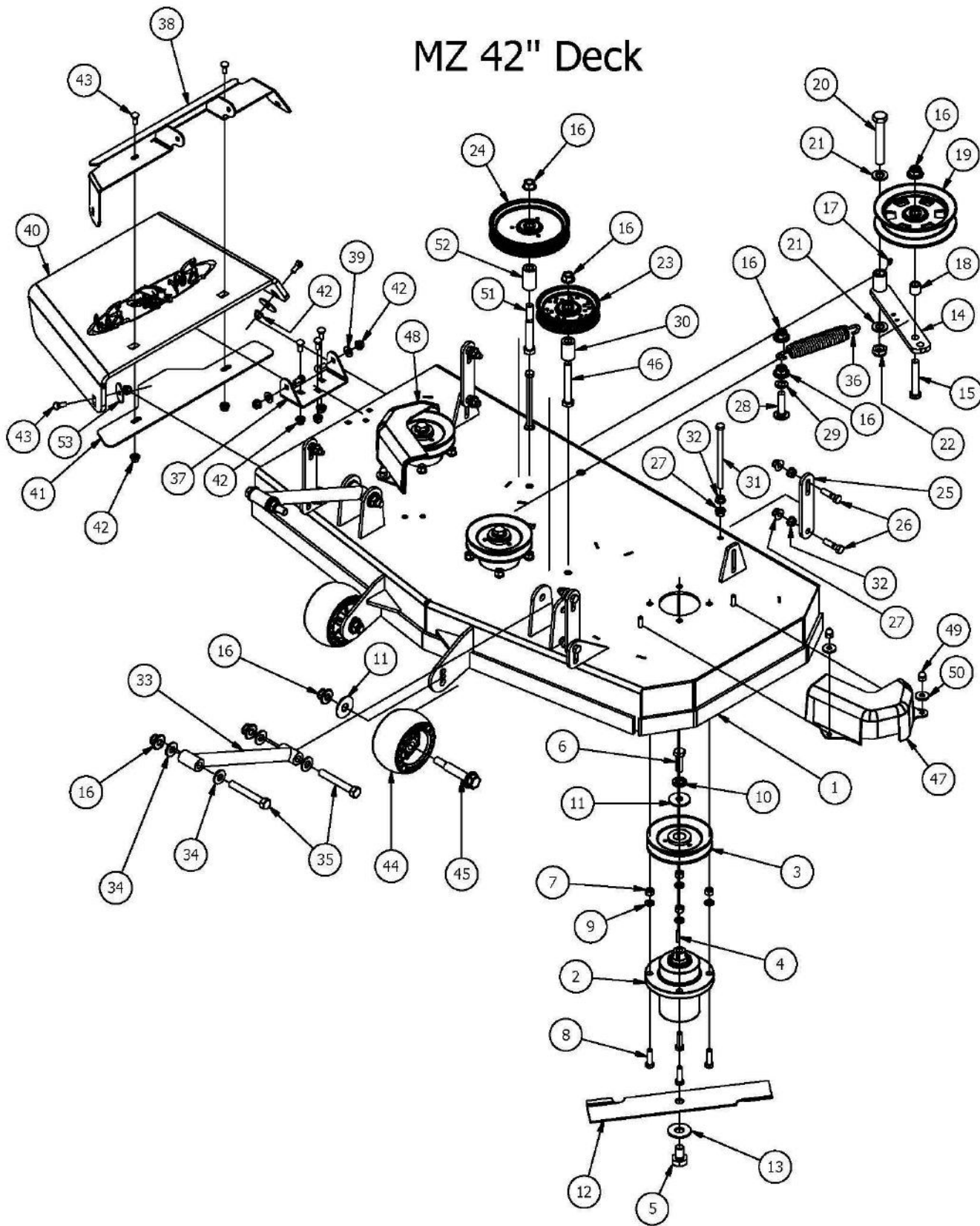



Parts List			
ITEM	QTY	PART NUMBER	DESCRIPTION
1	1	060-2442-00	2017 42" MZ Deck-Welded Shell
2	3	037-2000-00	Spindle
3	3	033-4820-00	MZ Deck Pulley
4	3	042-0010-00	3/16 x 1 Square Key
5	3	018-6020-00	5/8" x 1 1/2" Grade 8 Hex Bolt (Fine)
6	3	018-6019-00	1/2"-20 x 1 1/2 - Grade 5 Fine Thread Bolt
7	12	013-6014-00	3/8" Hex Nut
8	12	018-5040-00	3/8" x 1 1/4" Hex Bolt
9	12	019-5037-00	3/8" Lock Washer
10	3	019-5007-00	1/2" Lock Washer Zinc
11	5	019-6020-00	1/2" Belleville Washer
12	3	038-4221-00	MZ 42 Blade
13	3	019-5038-00	5/8" Flat Washer
14	1	039-6945-00	Deck Idler
15	1	018-7016-00	1/2-13 x GR 5 Hex Bolt Zinc
16	11	013-8050-00	1/2-13 Nylon Insert Flange Nut
17	1	024-6034-00	1/4" Press in Grease Fitting
18	1	025-5203-00	Spacer 3/4 OD x 1/2 ID x 3\4 Length
19	1	033-8050-00	5" Idler Pully
20	1	018-5311-00	5/8" x 4" Hex Bolt
21	2	019-6017-00	.630 ID Plastic Washer
22	1	013-5301-00	5/8-11 Nylon Insert Jam Half Nut
23	1	033-6001-00	4 3/4 Idler Pulley - ABFI-76
24	1	033-7201-25	5-3/4 Idler Pulley-Capitol Stampings
25	4	039-2127-00	2017 MZ/ZT Deck Hanger
26	8	018-6012-00	3/8" x 1 1/2" Hex Bolt
27	10	013-5202-00	3/8 Nylock Flange Nut
28	1	018-1050-00	1/2 x 2" Carriage Bolt
29	1	019-0007-00	.517 Square Hole Round Washer
30	1	025-5338-00	Idler Pulley Standoff
31	2	018-7060-00	3/8-16 x 5 1/2 Hex Bolt
32	10	013-5201-00	3/8" Flange Nut
33	2	028-0004-00	MZ/ZT Deck Locator
34	8	019-8054-00	.505 Nylon Spacer
35	4	018-6054-00	1/2-13 x 3 1/2 GR 5 Hex Bolt
36	1	034-2020-00	2015 Deck Idler Spring
37	1	206-6020-00	Chute Hanger 48 MZ
38	1	039-4891-00	Discharge Chute Bracket 48 MZ (Upper)
39	2	019-6042-00	.360 ID Plastic Washer
40	1	210-6014-00	Rubber Discharge Chute MZ (Component)
41	1	039-4892-00	2017 MZ Discharge Chute Bracket-Lower
42	9	013-8049-00	5/16" Nylon Flange Nut
43	9	018-8062-00	5/16-18x3/4 carriage bolt
44	2	022-1000-00	Deck Wheel
45	2	018-0010-00	Deck Wheel Bolt
46	1	018-2018-00	1/2 x 3 1/2 Flange Bolt Grade 8
47	1	014-4026-00	pulley cover non-chute side
48	1	014-4025-00	pulley cover chute side
49	4	013-0004-00	Acorn nut-pulley Cover
50	4	019-6050-00	.360 ID Plastic Washer-Black
51	1	018-5019-00	1/2" x 4" Bolt (Grade 8)
52	1	025-5339-00	1 3/4" Pulley Spacer
53	2	019-9002-00	5/16" Fender Washer

# MZ 48" Deck

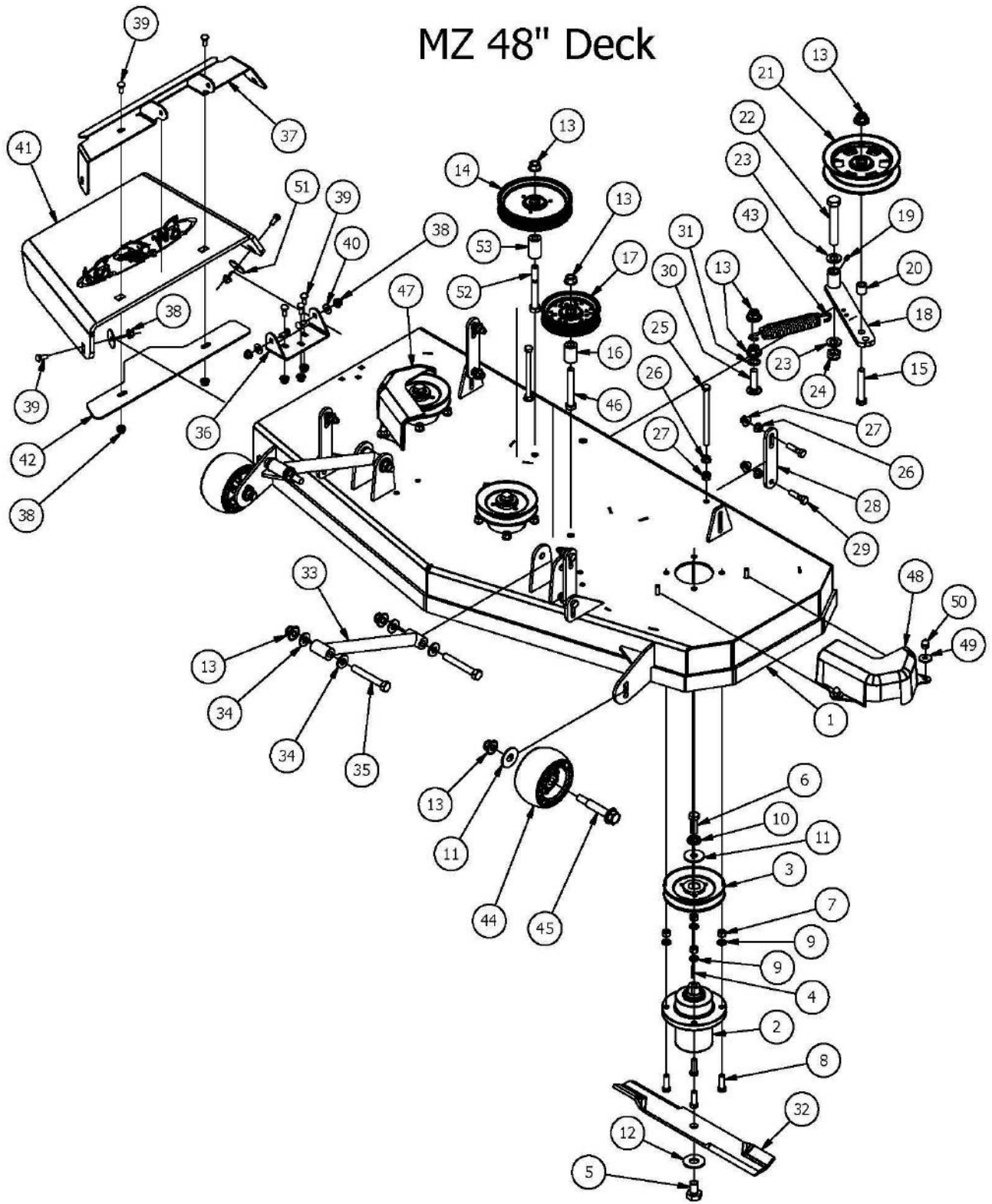





Parts List			
ITEM	QTY	PART NUMBER	DESCRIPTION
1	1	060-2448-00	2017 48" MZ Deck-Welded Shell
2	3	037-2000-00	Spindle
3	3	033-4820-00	MZ Deck Pulley
4	3	042-0010-00	3/16 x 1 Square Key
5	3	018-6020-00	5/8" x 1 1/2" Grade 8 Hex Bolt (Fine)
6	3	018-6019-00	1/2"-20 x 1 1/2 - Grade 5 Fine Thread Bolt
7	12	013-6014-00	3/8" Hex Nut
8	12	018-5040-00	3/8" x 1 1/4" Hex Bolt
9	12	019-5037-00	3/8" Lock Washer
10	3	019-5007-00	1/2" Lock Washer Zinc
11	5	019-6020-00	1/2" Belleville Washer
12	3	019-5038-00	5/8" Flat Washer
13	11	013-8050-00	1/2-13 Nylon Insert Flange Washer
14	1	033-7201-25	5-3/4 Idler Pulley-Capitol Stampings
15	1	018-7016-00	1/2-13 x GR 5 Hex Bolt Zinc
16	1	025-5338-00	Idler Pulley Standoff
17	1	033-6001-00	4 3/4 Idler Pulley - ABFI-76
18	1	039-6945-00	Deck Idler
19	1	024-6034-00	1/4" Press in Grease Fitting
20	1	025-5203-00	Spacer 3/4 OD x 1/2 ID x 3/4 Length
21	1	033-8050-00	5" Idler Pulley
22	1	018-5311-00	5/8" x 4" Hex Bolt
23	2	019-6017-00	.630 ID Plastic Washer
24	1	013-5301-00	5/8-11 Nylon Insert Jam Half Nut
25	2	018-7060-00	3/8-16 x 5 1/2 Hex Bolt
26	10	013-5201-00	3/8" Flange Nut
27	10	013-5202-00	3/8 Nylock Flange Nut
28	4	039-2127-00	2017 MZ/ZT Deck Hanger
29	8	018-6012-00	3/8" x 1 1/2" Hex Bolt
30	1	018-1050-00	1/2 x 2" Carriage Bolt
31	1	019-0007-00	.517 Square Hole Round Washer
32	3	038-4826-00	48" High Lift Fusion Blade
33	2	028-0004-00	MZ/ZT Deck Locator
34	8	019-8054-00	.505 Nylon Spacer
35	4	018-6054-00	1/2-13 x 3 1/2 GR 5 Hex Bolt
36	1	206-6020-00	Chute Hanger 48 MZ
37	1	039-4891-00	Discharge Chute Bracket 48 MZ (Upper)
38	9	013-8049-00	5/16" Nylon Flange Nut
39	9	018-8062-00	5/16-18x3/4 carriage bolt
40	2	019-6042-00	.360 ID Plastic Washer
41	1	210-6014-00	Rubber Discharge Chute MZ (Component)
42	1	039-4892-00	2017 MZ Discharge Chute Bracket-Lower
43	1	034-2020-00	2015 Deck Idler Spring
44	2	022-1000-00	Deck Wheel
45	2	018-0010-00	Deck Wheel Bolt
46	1	018-2018-00	1/2 x 3 1/2 Flange Bolt Grade 8
47	1	014-4025-00	pulley cover chute side
48	1	014-4026-00	pulley cover non-chute side
49	4	019-6050-00	.360 ID Plastic Washer-Black
50	4	013-0004-00	Acorn nut-pulley Cover
51	2	019-9002-00	5/16" Fender Washer
52	1	018-5019-00	1/2" x 4" Bolt (Grade 8)
53	1	025-5339-00	1 3/4" Pulley Spacer

# MZ 54" Deck

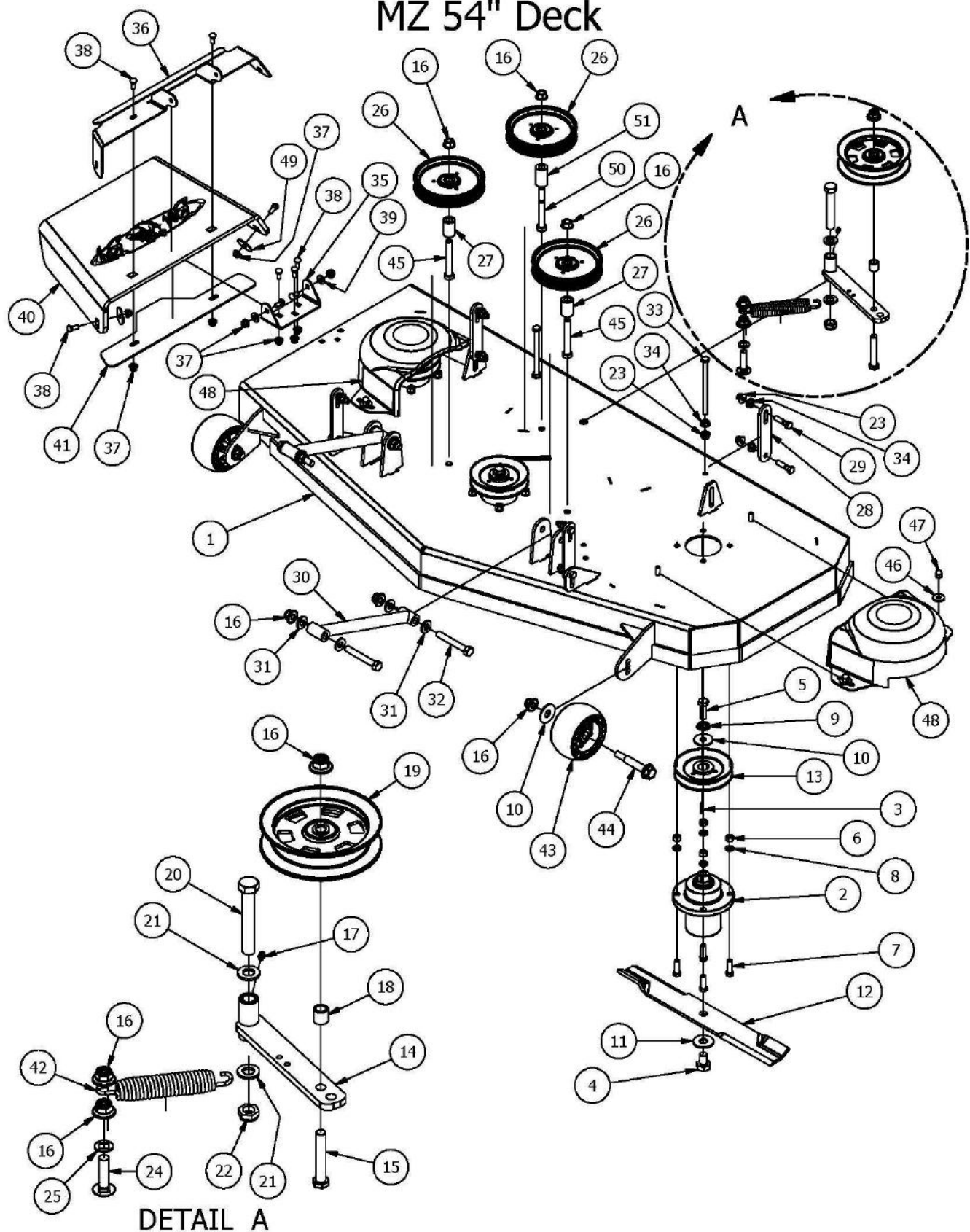

DETAIL A



Parts List			
ITEM	QTY	PART NUMBER	DESCRIPTION
1	1	060-2417-00	2017 MZ 54" Deck
2	3	037-2000-00	Spindle
3	3	042-0010-00	3/16 x 1 Square Key
4	3	018-6020-00	5/8" x 1 1/2" Grade 8 Hex Bolt (Fine)
5	3	018-6019-00	1/2"-20 x 1 1/2 - Grade 5 Fine Thread Bolt
6	12	013-6014-00	3/8" Hex Nut
7	12	018-5040-00	3/8" x 1 1/4" Hex Bolt
8	12	019-5037-00	3/8" Lock Washer
9	3	019-5007-00	1/2" Lock Washer Zinc
10	5	019-6020-00	1/2" Belleville Washer
11	3	019-5038-00	5/8" Flat Washer
12	3	038-0005-00	54" MZ Fusion Blade
13	3	033-4890-00	54 MZ Spindle Pulley
14	1	039-6945-00	Deck Idler
15	1	018-7016-00	1/2-13 x GR 5 Hex Bolt Zinc
16	12	013-8050-00	1/2-13 Nylon Insert Flange Nut
17	1	024-6034-00	1/4" Press in Grease Fitting
18	1	025-5203-00	Spacer 3/4 OD x 1/2 ID x 3\4 Length
19	1	033-8050-00	5" Idler Pully
20	1	018-5311-00	5/8" x 4" Hex Bolt
21	2	019-6017-00	.630 ID Plastic Washer
22	1	013-5301-00	5/8-11 Nylon Insert Jam Half Nut
23	10	013-5202-00	3/8 Nylock Flange Nut
24	1	018-1050-00	1/2 x 2" Carriage Bolt
25	1	019-0007-00	.517 Square Hole Round Washer
26	3	033-7201-25	5-3/4 Idler Pulley-Capitol Stampings
27	2	025-5338-00	Idler Pulley Standoff
28	4	039-2127-00	2017 MZ/ZT Deck Hanger
29	8	018-6012-00	3/8" x 1 1/2" Hex Bolt
30	2	028-0004-00	MZ/ZT Deck Locator
31	8	019-8054-00	.505 Nylon Spacer
32	4	018-6054-00	1/2-13 x 3 1/2 GR 5 Hex Bolt
33	2	018-7060-00	3/8-16 x 5 1/2 Hex Bolt
34	10	013-5201-00	3/8" Flange Nut
35	1	206-6020-00	Chute Hanger 48 MZ
36	1	039-4891-00	Discharge Chute Bracket 48 MZ (Upper)
37	9	013-8049-00	5/16" Nylon Flange Nut
38	9	018-8062-00	5/16-18x3/4 carriage bolt
39	2	019-6042-00	.360 ID Plastic Washer
40	1	210-6014-00	Rubber Discharge Chute MZ (Component)
41	1	039-4892-00	2017 MZ Discharge Chute Bracket-Lower
42	1	034-2020-00	2015 Deck Idler Spring
43	2	022-1000-00	Deck Wheel
44	2	018-0010-00	Deck Wheel Bolt
45	2	018-2018-00	1/2 x 3 1/2 Flange Bolt Grade 8
46	4	019-6050-00	.360 ID Plastic Washer-Black
47	4	013-0004-00	Acorn nut-pulley Cover
48	2	014-4000-00	Pulley Cover
49	2	019-9002-00	5/16" Fender Washer
50	1	018-5019-00	1/2" x 4" Bolt (Grade 8)
51	1	025-5339-00	1 3/4" Pulley Spacer

# 037-2000-00 Spindle Assembly

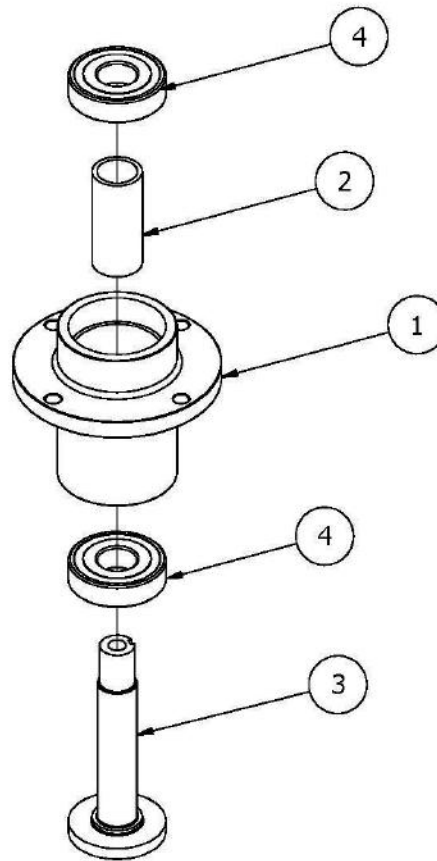

Parts List			
ITEM	QTY	PART NUMBER	DESCRIPTION
1	1	037-6027-00	Spindle Housing
2	1	037-6028-00	Spindle Spacer-Component
3	1	037-6025-00	Spindle Shaft
4	2	037-6024-00	Spindle Bearing



091-1046-00  
MZ Front Grill Decal



091-1048-00  
42" Deck Decal



091-1047-00 MZ 540cc  
Decal Rear Plate

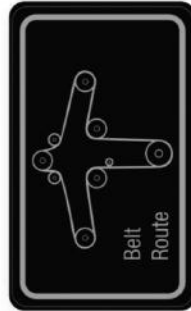

091-3309-00  
Deck Belt Route Decal

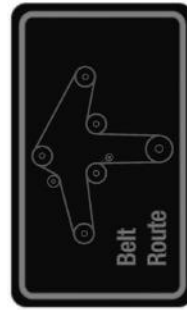

091-0393-00  
MZ Belt Route Decal



091-0313-00  
MZ Logo Decal Front



091-0211-00  
MZ 725cc Decal Rear Plate



091-0206-00  
Magnum Left Steering  
Speed Control Decal



091-0207-00  
Magnum Right Steering  
Speed Control Decal



091-0903-00  
48" Deck Decal



091-0318-00  
MZ Magnum 725cc  
Decal Rear Plate



091-0904-00  
54" Deck Decal



091-0319-00  
MZ Magnum 726cc  
Decal Rear Plate



091-3012-00  
Danger Decal  
Spindle/Discharge



091-0391-00  
MZ Magnum Front Grill Decal



091-0339-00  
Brake Decal



091-0338-00  
Instrument Panel Decal



091-3017-00  
Pump Belt Route Decal



091-3150-00  
Outlaw Warning Decal



---

# LIMITED WARRANTY FOR BAD BOY MZ MOWERS

## 1. WHAT THIS WARRANTY COVERS, AND FOR HOW LONG:

Bad Boy, Inc. will, at its option, repair or replace, without charge, any part covered by the warranty which is found to be defective in material and/or workmanship for two (2) years or (200) hours\* after the date of sale to the original retail purchaser **unless the product is used for commercial, industrial, or rental purposes, in which case the Bad Boy MZ mower will carry no warranty, whatsoever.**

Belts are warranted for a period of ninety (90) days against materials or workmanship defects.

Seats are warranted for a period of (6) months against material or workmanship defects.

At Bad Boy, Inc.'s request, customer will make the defective part available for inspection by Bad Boy, Inc. and/or return the defective part to Bad Boy, Inc., **transportation charges prepaid.**

## 2. WHAT THIS WARRANTY DOES NOT COVER:

A. This warranty does not cover defects caused by depreciation or damage caused by normal wear, accidents, improper maintenance, improper use or abuse of the product, alterations, or failure to follow the instruction contained in the Owner's Manual for operation and maintenance.

B. The customer shall pay any charges for making service calls and/or for transporting the mower to and from the place where the inspection and/or warranty work is performed.

**Bad Boy Inc will not be responsible for the pickup and delivery of a machine for warranty purposes.**

C. Engines are warranted separately by their respective manufacturer. The available warranties covering this item are furnished with each mower. Bad Boy, Inc does not assume any warranty obligation, liability or modification for this item, which is covered exclusively by the stated warranty of the respective manufacturers.

D. Tires, blades, deck anti-scalping wheels, and dust covers are considered to be consumable wear items and are therefore not warranted.

E. Batteries are warranted for six months (free replacement) from the retail purchase date against materials or workmanship defects. The battery warranty must be obtained through the battery manufacturer.

F. Normal maintenance services such as oil change, cleaning, lubrication, adjustment.

G. Replacement of services, items, such as oil, lubricants, spark plugs, belts, rubber hoses or other items subject to normal service replacement.

## 3. HOW TO OBTAIN SERVICE UNDER THIS WARRANTY:

A. Warranty service can be arranged by contacting the dealer where you purchased the mower. Proof of the date of purchase may be required to verify warranty coverage. Warranty repairs must be completed by an authorized Bad Boy center.

**B. Warranty claims will not be reviewed or paid unless the warranty registration is received by Bad Boy, Inc. within 30 days of the retail purchase date.**

C. Warranty claims requiring parts returned will be settled upon return of parts to Bad Boy for inspection.

D. All warranty issues must be handled through an authorized service center or dealership.

## 4. WARRANTY LIMITATION:

A. **THERE IS NO OTHER EXPRESS WARRANTY. ANY WARRANTY THAT MAY BE IMPLIED FROM THIS PURCHASE INCLUDING MERCHANTABILITY AND FITNESS FOR A PARTICULAR PURPOSE IS HEREBY LIMITED TO THE DURATION OF THIS WARRANTY AND TO THE EXTENT PERMITTED BY LAW ANY AND ALL IMPLIED WARRANTIES ARE EXCLUDED.** Some states do not allow limitations on how long an implied warranty lasts, so the above limitations may not apply to you.

B. **BAD BOY, INC. WILL NOT BE LIABLE FOR ANY INCIDENTAL, CONSEQUENTIAL, OR SPECIAL DAMAGES AND/OR EXPENSES IN CONNECTION WITH THE PURCHASE OR USE OF THE MOWER.** Some states do not allow the exclusion or limitation of incidental or consequential damages, so the above limitation(s) or exclusion(s) may not apply to you.

C. Only the warranty expressed in this limited warranty shall apply and no dealer, distributor, or individual is authorized to amend, modify, or extend this warranty in any way. Accordingly, additional statements such as dealer advertising or presentations, whether oral or written, do not constitute warranties by Bad boy, Inc., and should not be relied on.

D. This warranty extends only to turf equipment operated under normal conditions and properly serviced and maintained. The warranty expressly does not cover (i) any defects, damage or deterioration due to normal use, wear and tear, or exposure; (ii) normal maintenance services such as oil change, cleaning, lubrication, adjustment; (iii) replacement of services, items, such as oil, lubricants, spark plugs, belts, rubber hoses or other items subject to normal service replacement; (iv) damage or defects arising out of or relating to misuse, neglect, alteration, negligence or accident; (v) repair or replacement arising from operation of or use of the turf equipment which is not in accordance with operating instructions as specified in the operator's manual or other operational instructions provided by Bad Boy Inc.; (vi) repair or replacement arising as a result of any operation from turf equipment that has been altered or modified so as to, indetermination of Bad Boy, Inc., adversely affect the operation, performance or durability of the equipment or that has altered, modified or affected the turf equipment so as to change the intended use of the product; (vii) repair or replacement necessitated by use of parts, accessories or supplies, including gasoline, oil or lubricants, incompatible with the turf equipment or other than as recommended in the operator's manual or other operational instructions provided by Bad Boy, Inc.; (viii) repairs or replacements resulting from parts or accessories which have adversely affected the operation, performance or durability of the turf equipment; or (ix) damage or defects due to or arising out of repair of turf equipment by person or persons other than an authorized Bad Boy, Inc., service dealer or the installation of parts other than genuine Bad Boy, Inc., recommended parts.  
**As a condition to this warranty, customer shall have read the operator's manual and ensured the mower has been registered within 30 days of purchase.**

E. This warranty gives you specific legal rights, and you may also have other rights, which vary from state to state.

---

**Bad Boy, Inc.**  
**102 Industrial Drive**  
**Batesville, AR 72501**  
**www.badboymowers.com**

**Technical Support:** .....techsupport@badboymowers.com

**Warranty:** .....warranty@badboymowers.com

**Parts:** .....partsdept@badboymowers.com

## **WARRANTY REGISTRATION**

**Ensure selling dealership has registered mower within  
30 days of purchase to validate warranty.**

Please record your serial number, date of purchase and dealership information  
for your records.

Serial # \_\_\_\_\_

Date of Purchase \_\_\_\_\_

Dealer Information \_\_\_\_\_

# MZ MODEL



For additional information, please see us at  
**[www.badboymowers.com](http://www.badboymowers.com)**

Bad Boy, Inc.  
102 Industrial Drive  
Batesville, Arkansas 72501