



# **OUTLAW & OUTLAW EXTREME MODELS**

## **ZERO-TURN MOWER OWNER'S, SERVICE & PARTS MANUAL**

For additional information, please see us at  
[www.badboymowers.com](http://www.badboymowers.com)

Bad Boy, Inc.  
102 Industrial Drive  
Batesville, Arkansas 72501

---

# TABLE OF CONTENTS

Basic Information.....	Section 1 (page 4)
Bad Boy Safety Guidelines .....	Section 2 (pages 5–8)
Operation .....	Section 3 (pages 9)
Maintenance .....	Section 4 (page 10)
Storage and Transportation .....	Section 5 (page 12)
Troubleshooting and FAQ.....	Section 6 (page 13)
Controls .....	Section 7 (page 14)
Moving In-operable Mower .....	Section 8 (page 15)
Instrumentation .....	Section 9 (page 15)
Mower Blade Maintenance .....	Section 10 (page 16)
Greasing Bearings.....	Section 11 (pages 16)
How to choose the right blade .....	Page 17
Mowing Tips .....	Page 18
Service Section .....	Page 19
Parts Section .....	Page 53
Limited Warranty .....	Page 78



## This manual applies to the following equipment:

### Bad Boy Outlaw Series

Outlaw 5400 54" 810cc Vanguard  
 Outlaw 6100 61" 810cc Vanguard  
 Outlaw 5400 54" 747cc Kohler Confidant  
 Outlaw 6100 61" 747cc Kohler Confidant  
 Outlaw 5400 54" 726cc Kawasaki FX-730  
 Outlaw 6100 61" 726cc Kawasaki FX-730

### Bad Boy Outlaw Extreme Series

Outlaw Extreme 5400 54" 824cc Kohler EFI  
 Outlaw Extreme 6100 61" 824cc Kohler EFI  
 Outlaw Extreme 5400 54" 852cc Kawasaki FX-850  
 Outlaw Extreme 6100 61" 852cc Kawasaki FX-850  
 Outlaw Extreme 7200 72" 852cc Kawasaki FX-850  
 Outlaw Extreme 6100 61" 993cc Vanguard  
 Outlaw Extreme 7200 72" 993cc Vanguard

## COMMONLY USED ITEMS AND PART NUMBERS

72" Blade	Hi-Lift Fusion 038-7230-00	Gator Blade 038-5400-00	Wave Blade 0038-7215-00	
61" Blade	Hi-Lift Fusion 038-6080-00	Gator Blade 038-6081-00	Wave Blade 038-6090-00	
54" Blade	Hi-Lift Fusion 038-0001-00	Gator Blade 038-0003-00	Wave Blade 038-5220-00	
Deck Belt	72" 041-0202-00	61" 041-0178-00	54" 041-1650-00	
Pump Belt	041-8411-00			
Spark Plug	Vanguard 810cc Vanguard 993cc 015-8000-00	Kawasaki FX 730v Kawasaki FX 850v 015-8001-00	Kohler Confidant 018-8000-00	Kohler Command Pro EFI ECV870 015-8002-00
Air Filter	Vanguard 993cc Kawasaki FX 850v Kohler Command Pro EFI ECV870*	Vanguard 810cc Kawasaki FX 730v	Kohler Confidant	
	Inner 063-8020-00	Outer 063-8019-00	Paper Element 063-5005-00	Pre-Cleaner 063-5006-00
Oil Filter	Vanguard 810cc Vanguard 993cc 063-8018-00	Kawasaki FX 730v Kawasaki FX850V 063-8017-00	Kohler Comand Pro EFI ECV870 Kohler Confidant 063-5004-00	
Motor Oil	10W-30 Motor Oil - Bad Boy Synthetic Blend Motor Oil Recommended			
Hydraulic Oil	20W-50 Motor Oil - Bad Boy Hydrostatic Oil Recommended; approximately 2 quarts per side			
Hydraulic Filters	Vanguard 810cc Kawasaki FX 730v Kohler Confidant 063-1070-00	Vanguard 993cc Kawasaki FX 850v Kohler Command Pro EFI ECV870 063-8014-00		

\* Outer Air Filter Only

---

## SECTION 1: BASIC INFORMATION

Congratulations on the purchase of your new Bad Boy Mower! The purpose of this manual is to assist operators in maintaining and operating their machine. The information and instructions in this manual can help you attain years of performance from your new Bad Boy. Also, check out our website to learn more about the Bad Boy family.

- 1.1 All Bad Boy engines use 10W-30 engine oil. For maximum protection, Bad Boy synthetic blend engine oil is recommended.
- 1.2 All Bad Boy hydraulic systems use 20W-50 engine oil (Conventional or Synthetic). Bad Boy Hydrostatic oil is recommended.
- 1.3 All Bad Boy Mowers use hi-temp multi-purpose grease. NLGI No. 2 for the grease fittings.
- 1.4 Outlaw models have 12 psi in both front and rear tires.
- 1.5 Most Briggs, Kohler, Kawasaki, and Vanguard engines hold approximately two (2) quarts of motor oil. Be careful not to over fill engine oil. Refer to the engine's service manual.

### Warranty Registration

The Warranty Registration form must be completed within 30 days to validate your warranty. As the new equipment owner, you are expected to see that the form is completed and forwarded to Bad Boy, Inc., at time of delivery. Warranty is non transferable. **Warranty registration should be completed by the selling dealership using the on-line registration site.**

### Model/Serial Number

Your Outlaw model serial numbers are found on the SIN plate underneath seat. Also, these numbers can assist you in the ordering of new parts when replacements become necessary.

### Parts/Service

Only Bad Boy replacement parts are to be used on your mower.

Replacement parts are available through your local Bad Boy Mower Dealer. Remember to always provide the following information when ordering parts:

1. Correct part number
2. Correct serial number

All warranty repair and service must be handled through your authorized Bad Boy Mowers dealer.

To locate the nearest dealer, go to our website and click on Locate a Dealer.

## EVAPORATIVE EMISSION CONTROL WARRANTY STATEMENT

### ***Federal Evaporative Emission Control Warranty: Your Warranty Rights and Obligations***

The Environmental Protection Agency (EPA), and Bad Boy Inc. are pleased to explain the evaporative emission control system's warranty on your 2016 equipment. New equipment that uses spark ignition engines for off-road use must meet stringent anti-smog standards. The evaporative emission control system on your equipment is designed, built, and equipped so it conforms at the time of sale to the ultimate purchaser with the requirements of 40 CFR 1060. The evaporative emission control system is free from defects in materials and workmanship that may keep it from meeting said requirements. Bad Boy Inc. must warrant the evaporative emission control system on your equipment for two years provided there has been no abuse, neglect or improper maintenance. If an evaporative emission control system component does fail in a manner that would cause the equipment to no longer meet the requirements of 40 CFR 1060 within the first two years Bad Boy Inc. will replace the defective component. Your evaporative emission control system may include parts such as fuel tanks, fuel lines, carbon canisters, fuel caps, valves, vapor hoses, clamps, or connectors.



---

## SECTION 2: MOWER SAFETY GUIDELINES

Never allow untrained people to operate this machine. It is the owner's responsibility to get training and see to it that anyone who has permission to use your machine receives the proper training. Do not mow around people. The factory discharge chute is designed to deflect debris downward, but it could be possible for debris to be thrown in a way that can cause damage to people or property. Seek additional training when possible to learn more about safety techniques and practices. **This cutting machine is capable of amputating hands and feet and throwing objects. Failure to observe the following safety instructions could result in serious injury or death.**

### GENERAL OPERATION

- 2.1 Read, understand, and follow all instructions on the machine and in the manual before starting.
- 2.2 Do not put hands or feet near rotating parts or under the machine. Keep clear of the discharge opening at all times.
- 2.3 Always remain seated while operating the machine. If the machine is equipped with Roll Over Protection (ROPs), always buckle your seat belt.
- 2.4 Only allow responsible adults who are familiar with the instructions to operate this machine.
- 2.5 Clear the area of objects such as rocks, wire, toys, etc., which could be thrown by the blades.
- 2.6 Always maintain a safe distance from people and pets just prior to, and during, operation. Stop the machine if anyone enters the area.
- 2.7 Never carry passengers.
- 2.8 Do not mow in reverse unless absolutely necessary. Always look down and behind before and while backing.
- 2.9 Never direct discharged material toward anyone. Avoid discharging material against a wall or obstruction as material may ricochet back toward the operator. Stop the blades when crossing gravel surfaces.
- 2.10 Never operate the machine without the discharge chute, grass catcher, or other safety devices correctly in place and functioning properly.
- 2.11 Slow down before turning.
- 2.12 Always disengage blades, place steering controls in neutral, engage parking brake, and remove ignition key when leaving operators seat. Never leave a running machine unattended.
- 2.13 Disengage blades when not mowing. Shut off engine and wait for all parts to come to a complete stop before cleaning the machine, inspecting the machine for damage, removing the grass catcher, or unclogging the discharge guard.
- 2.14 Always operate machine in daylight or with adequate working lights.
- 2.15 Do not operate the machine while under the influence of alcohol or drugs.
- 2.16 Watch for traffic when operating near or crossing roadways.
- 2.17 Always wear eye protection when operating or servicing the machine.
- 2.18 Always wear ear protection, such as earplugs, while mowing.
- 2.19 Use extra care when loading or unloading the machine into a trailer or truck.
- 2.20 Be alert of surroundings. Watch for rocks, stumps, mounds, depressions, and low hanging limbs or objects that could be potentially hazardous while mowing.
- 2.21 Data indicates that operators 60 years of age and above are involved in a large percentage of riding mower related injuries. These operators should periodically evaluate their ability to operate the riding mower safely enough to protect themselves and others from serious injury.

---

## SLOPE OPERATION

Slopes are a major factor related to loss of control and tip over accidents, which can result in severe injury or death. Operation on all slopes requires extra caution. If you cannot back up the slope, or you feel uneasy on it, do not mow it.

- 2.22 Mow up and down slopes, not across.
- 2.23 Watch for holes, ruts, bumps, rocks, or other hidden objects that tall grass can obscure. Uneven terrain could overturn the machine.
- 2.24 Choose a low ground speed when operating the machine on a slope.
- 2.25 Do not mow on wet grass, the tires may lose traction.
- 2.26 Do not attempt to coast down a slope in the neutral position.
- 2.27 Avoid starting, stopping, or turning on a slope. If the tires lose traction, disengage the blades and proceed slowly, straight down the slope.
- 2.28 Keep all movement on slopes slow and gradual. Sudden changes in speed or direction could cause the machine to roll over.
- 2.29 Use extra care while operating machine with grass catchers or other attachments: they can affect the stability of the machine. Do not use on steep slopes.
- 2.30 Do not try to stabilize the machine by putting your foot on the ground.
- 2.31 Do not mow near drop offs, ditches or embankments. The machine could suddenly roll over if a wheel goes over the edge or the edge caves in.
- 2.32 Be aware of what is located at the bottom of slopes. For example: rocks water, cliffs, and roadways.

## CHILDREN

Tragic accidents can occur if the operator is not alert to the presence of children. Children are often attracted to the machine and the mowing activity. NEVER assume that children will remain where you last saw them.

- 2.33 Keep children out of the mowing area and in the watchful care of a responsible adult other than the operator.**
- 2.34 Maintain alertness and turn machine off if a child enters the area.**
- 2.35 Before and while backing, look behind and down for small children.**
- 2.36 Never carry children, even with the blades shut off. They may fall off and be seriously injured or interfere with safe machine operation. Children who have been given rides in the past may suddenly appear in the mowing area for another ride and be run over or backed over by the machine.**
- 2.37 Never allow children to operate the machine.**
- 2.38 Never leave key in the ignition, especially around children.**
- 2.39 Use extreme care when approaching blind corners, shrubs, trees, or other objects that may block your view of a child.**

## TOWING

- 2.40 Tow only with a machine that has a hitch specifically designed for towing. Do not attach towed equipment except at the hitch point.
- 2.41 Follow the manufacturer's recommendation for weight limits for towed equipment and towing on slopes.
- 2.42 Never allow children or others in or on towed equipment.
- 2.43 On slopes, the weight of the towed equipment may cause loss of traction and loss of control.
- 2.44 Travel slowly and allow extra distance to stop.



---

## SERVICE:

### SAFE HANDLING OF GASOLINE

To avoid personal injury or property damage, use extreme care in handling gasoline. Gasoline is extremely flammable and the vapors are explosive.

- 2.45 Extinguish all cigarettes, cigars, pipes, and all other sources of ignition.
- 2.46 Use only an approved gasoline container.
- 2.47 Never remove gas cap or add fuel with the engine running.
- 2.48 Allow engine to cool before refueling.
- 2.49 Never fuel the machine indoors.
- 2.50 Do not store machine near open flame or source of ignition, such as a water heater or furnace.
- 2.51 Remove gas powered equipment from the truck or trailer and refuel it on the ground. If this is not possible, then refuel such equipment with a portable container, rather than from a gasoline dispenser nozzle.
- 2.52 Never fill gasoline containers inside a vehicle or on a truck or trailer bed with a plastic liner. Always place containers on the ground away from your vehicle before filling.
- 2.53 Keep the nozzle in contact with the rim of the fuel tank or container opening at all times until the fueling is complete. Do not use a nozzle lock-open device.
- 2.54 If fuel is spilled on clothing, change clothing immediately.
- 2.55 Never overfill fuel tank. Replace gas cap and tighten securely. **Tank is full when level reaches bottom of fill tube.**

### GENERAL SERVICE

- 2.56 Never operate machine in a closed area where dangerous carbon monoxide fumes can collect.
- 2.57 Keep all nuts and bolts tight to be sure the equipment is in safe working condition. Never operate a poorly maintained machine.
- 2.58 Do not touch hot areas of the machine.
- 2.59 Never interfere with the intended function of a safety device or reduce the protection provided by a safety device. Check their proper operation regularly.
- 2.60 Keep the entire machine free of grass, leaves, or other debris build up. Clean up oil or fuel spillage and remove any fuel soaked debris. Failure to do so can affect the safety and functionality of the machine, as well as increase the danger of a fire due to contact with the hot surfaces of the machine.
- 2.61 Allow machine to cool before storing.
- 2.62 If you strike something with the mower, turn the mower and blades off, engage the parking brake, and inspect the machine for damage. Repair, if necessary, before resuming.
- 2.63 Never make any adjustments or repairs with the engine running.
- 2.64 Check grass catcher components and the discharge guard frequently and replace with manufacturer's recommended parts, when necessary.
- 2.65 Mower blades are sharp. Wrap the blade or wear gloves before servicing them.
- 2.66 Check parking brake operation frequently. Adjust and service as required.
- 2.67 Maintain or replace safety and instruction labels, as necessary.
- 2.68 Do not attempt to mount a tire without the proper equipment and experience to perform the job.

- 
- 2.69 Always maintain the correct tire pressure. Do not inflate the tires above the recommended pressure. Never weld or heat a wheel and tire assembly. The heat can cause an increase in air pressure resulting in a tire explosion. Welding can structurally weaken or deform the wheel.
- 2.70 Park machine on level ground. Never allow untrained personnel to service machine. Understand service procedure before doing work.

## SAFETY INTERLOCK SYSTEM

Your Bad Boy mower is equipped with a safety interlock system. This system is designed to prevent serious injury or death to the operator and other people or property damage. The system consists of an operator presence switch in the seat, the parking brake, drive lever neutral position, the mower blade engagement switch, and the ignition switch.

These interlocks are vitally important and must be tested frequently. Following are instructions to test these very important safety precautions. **Note: the operator must be seated properly on the machine during these tests and the engine should have been previously allowed to warm to operating temperature.**

- 2.71 With the parking brake engaged, bring lever arms to their inward position, then attempt to start the machine (the blade actuator should be in off position); the engine should not start.
- 2.72 On a level surface, disengage the parking brake and place lever arms to their outward position, then attempt to start the machine (the blade actuator should be in off position); the engine should not start.
- 2.73 Engage parking brake and leave lever arms in outward position, put blade actuator in the on position, then attempt to start the machine; the engine should not start.
- 2.74 Next, start the engine as stated in the "Mower Operation Section", disengage parking brake, and Very Slowly begin to rise from the seat; the engine should stop.

If any of these tests fail to produce the results indicated and the problem cannot be identified, contact your Bad Boy Mower dealer or the support contacts in the rear of this manual.

## ROLL OVER PROTECTION STRUCTURES (ROPS)

If your machine is equipped with ROPS, it is of utmost importance they are used properly. ROPS, when used correctly, dramatically decrease the fatality rate in instances when the machine overturns.

- 2.75 Periodically ensure the bolts that attach the ROPS to the machine are securely fastened.
- 2.76 Always operated the machine with the ROPS secured in the upright position.
- 2.77 If the surrounding environment (e.g. low lying limbs, signage, etc.) makes it impossible to mow with the ROPS upright, lower the ROPS at the hinge point, mow the area, then immediately secure the ROPS upright.
- 2.78 Upright ROPS are taller than then operators head. Be aware of this and your surrounding environment, as referenced above. The mower and operator may clear low lying items, but the ROPS may not.
- 2.79 Always wear the provided seat belt when ROPS are utilized. Failure to use the seat belt severely handicaps the safety benefits of the ROPS.
- 2.80 In the event of a roll-over, replace the ROPS before resuming use of the machine.





---

## SECTION 3: MOWER OPERATION

***Never operate the machine with faulty equipment. Always be alert of sudden changes in landscape, as the mower will react differently on slopes or embankments than it will on flat surfaces. Never operate the mower with the discharge chute open. Do not cross terrain, other than grass, with blades turning. This could cause damage to property or bystanders.***

- 3.1 Place parking brake in up position
- 3.2 Drive arms must be in the “open” position. While sitting on the machine, each arm is positioned away from the operator, to the right and left. Drive arms will lock into place and must be in this position to start machine.
- 3.3 Put PTO switch in the OFF position.
- 3.4 Your machine has been equipped with ROPS (Roll Over Protection System). The operator must fasten his or her seat belt while operating the mower.
- 3.5 If machine has not been started recently, engage the choke.
- 3.6 Make sure nothing is under or around machine.
- 3.7 Place key in ignition and turn.
- 3.8 Once machine is started, disengage the choke.
- 3.9 Increase RPM by sliding the throttle to fast position, toward the rabbit.
- 3.10 Owners must become familiar with the controls before operating a zero-turn radius vehicle.
- 3.11 Start slowly and build your skill level. Have ample practice before using the machine at full capabilities.
- 3.12 Be comfortable with machine before engaging blades. Know what each component controls before using machine.
- 3.13 Your mower will perform differently on an incline /decline. Be cautious, slow down, and do not make any sudden jerking movements with control arms. The machine could lose traction on a decline or tip backwards on an incline.
- 3.14 Once you become comfortable with your Bad Boy Mower you will notice your overall mowing time will decrease.

***Avoid operating your mower on side hills of over 5 degrees,  
inclines of over 10 degrees,  
and declines of over 15 degrees.***

# SECTION 4: MOWER MAINTENANCE

Maintenance	Interval					Section
	Daily	First 8 hours	Every 50 hours or annually*	Every 100 hours or annually*	Every 250 hours	
Check and add engine oil	•					Section 3
Check all belts for proper alignment	•					Section 2 (Pump) 6 (Deck)
Check tire pressure and wheel lug nuts	•					Section 5
Check battery terminal connections	•					Section 4
Check condition of blades	•					Section 6
Check for fule and oil leakage	•					Section 3
Initial oil change		•				Section 3
Change engine oil and filter			•			Section 3
Tighten nuts and screws			•			
initial change of hydraulic oil and filter			•			Section 1
Grease mower				•		Section 5
Replace air element and pre-cleaner ◇				•		Section 3
Replace fuel filter ◇				•		Section 3
Clean or replace spark plugs and set gap				•		Section 3
Change hudraulic oil and filter					•	Section 1
Clean combustion chamber <small>Dealer</small>					•	
Check and adjust valve clearance <small>Dealer</small>					•	
Clean and lap valve seating surface <small>Dealer</small>					•	

\*Maintenance by hour or annually, which ever comes first

◇ Check air and fuel filter more often in dusty conditions

Dealer Get maintenance performed at a registered dealership



# Maintenance Log

<i>Date:</i>	<i>Hours:</i>	<i>Performed:</i>
<i>Date:</i>	<i>Hours:</i>	<i>Performed</i>
<i>Date:</i>	<i>Hours:</i>	<i>Performed:</i>
<i>Date:</i>	<i>Hours:</i>	<i>Performed</i>
<i>Date:</i>	<i>Hours:</i>	<i>Performed</i>
<i>Date:</i>	<i>Hours:</i>	<i>Performed:</i>
<i>Date:</i>	<i>Hours:</i>	<i>Performed</i>
<i>Date:</i>	<i>Hours:</i>	<i>Performed:</i>
<i>Date:</i>	<i>Hours:</i>	<i>Performed</i>
<i>Date:</i>	<i>Hours:</i>	<i>Performed</i>
<i>Date:</i>	<i>Hours:</i>	<i>Performed:</i>
<i>Date:</i>	<i>Hours:</i>	<i>Performed:</i>
<i>Date:</i>	<i>Hours:</i>	<i>Performed</i>
<i>Date:</i>	<i>Hours:</i>	<i>Performed</i>
<i>Date:</i>	<i>Hours:</i>	<i>Performed</i>
<i>Date:</i>	<i>Hours:</i>	<i>Performed:</i>
<i>Date:</i>	<i>Hours:</i>	<i>Performed:</i>
<i>Date:</i>	<i>Hours:</i>	<i>Performed:</i>
<i>Date:</i>	<i>Hours:</i>	<i>Performed:</i>
<i>Date:</i>	<i>Hours:</i>	<i>Performed:</i>
<i>Date:</i>	<i>Hours:</i>	<i>Performed:</i>
<i>Date:</i>	<i>Hours:</i>	<i>Performed:</i>

---

## SECTION 5: MOWER STORAGE & TRANSPORTATION

- 5.1 Keep machine from collecting debris by storing in a covered area while not in use.
- 5.2 Fuel can harm your machine if left for more than 30 days without changing, especially if the fuel contains ethanol. Never use fuel with more than 10% ethanol by volume. E-15 is not permitted.
- 5.3 Disconnect the negative battery cable when machine will be stored for more than 30 days.
- 5.4 Always secure machine properly when transporting machine.
- 5.5 Do not load machine on trailer with blades engaged.
- 5.6 Do not use ramps to load the machine.
- 5.7 Make sure Parking Brake is in “up” position.
- 5.8 In wet conditions tires may spin while loading / unloading. If necessary, wait for dry conditions before loading / unloading.
- 5.9 Make sure mode of transportation is suitable to bear the weight of mower.
- 5.10 Deck height should be set at maximum before attempting to load.
- 5.11 Secure mower with at least two straps capable of securing weight of mower.



---

## SECTION 6: TROUBLESHOOTING

- 6.1 **Q:** *How do I prevent an uneven cutting pattern and increase the quality of cut?*
- 6.1 **A:** Check tire pressure, check blade sharpness (replace blades or sharpen at least once per year or when needed), make sure blades are tightened properly, check spring and belt tension, check the underside of the deck to ensure the mower deck is free of grass build-up and debris, make sure your machine is at full throttle, and vary your mowing pattern each time you cut your grass.
- 6.2 **Q:** *What should I do if my mower won't start?*
- 6.2 **A:** Check battery charge and connection (grounds), check your fuel (make sure fuel is less than 30 days old and contains no water), make sure your spark plug is in good condition and spark plug wire is attached, and make sure air filter is clean (a dirty filter makes it more difficult for the engine to draw air). Check the integrity of the 25 amp main fuse; also check for any bare wires and/or bad connections.
- 6.3 **Q:** *What should I do if the blades won't engage?*
- 6.3 **A:** Make sure the safety switch is plugged in on the bottom of seat. Check the underside of the PTO engager to ensure the plug is secure at switch.
- 6.4 **Q:** *What type of fuel is recommended for my mower?*
- 6.4 **A:** We recommend that you use a name brand fuel to ensure quality. Use fuel with an octane rating near 87. Higher octane fuels offer no benefit. By law, E-15 fuel is not permitted. Usage of E-15 will result in premature engine failure.
- 6.5 **Q:** *Do you offer touch-up paint for your mowers?*
- 6.5 **A:** Touch-up paint is available. Contact your local dealer for more information.
- 6.6 **Q:** *How durable is the electric deck lift?*
- 6.6 **A:** The actuator which controls the deck height is designed for moving loads of up to 1000 pounds and has a static holding capability which exceeds 3,000 pounds. Our ¼" deck weighs approximately 250 pounds which is only 25% of working capability.

---

## SECTION 7: CONTROLS

- 7.1 **Ignition Switch**—Bad Boy mowers have a three position ignition switch: off, run, and start. With key inserted, rotate it clockwise to START position and release key when engine starts. Switch will automatically return to the RUN position.
- 7.2 **Throttle Control**—A cable is connected to the engine throttle for controlling engine speed. Move lever forward to increase engine rpm, move lever backward to decrease engine rpm.
- 7.3 **Choke Control**—A cable is linked to manually operate the engine choke. When the lever is in the down position, the choke is in the off (run) position. When the lever is pulled up, the choke is in the on (start) position. Do not operate the machine in the on (start) position.
- 7.4 **Blade Engage Switch**—This switch engages the blades. Pull the switch up to engage; push the switch down to disengage.
- 7.5 **Parking Brake**—This lever engages the parking brake. Pull back fully to engage the parking brake; push forward to disengage.
- 7.6 **Control Arms (not pictured)**—These levers control the mower's speed and direction (left-right and forward-reverse). Pushing the arms to their outward-most position places the mower in neutral.

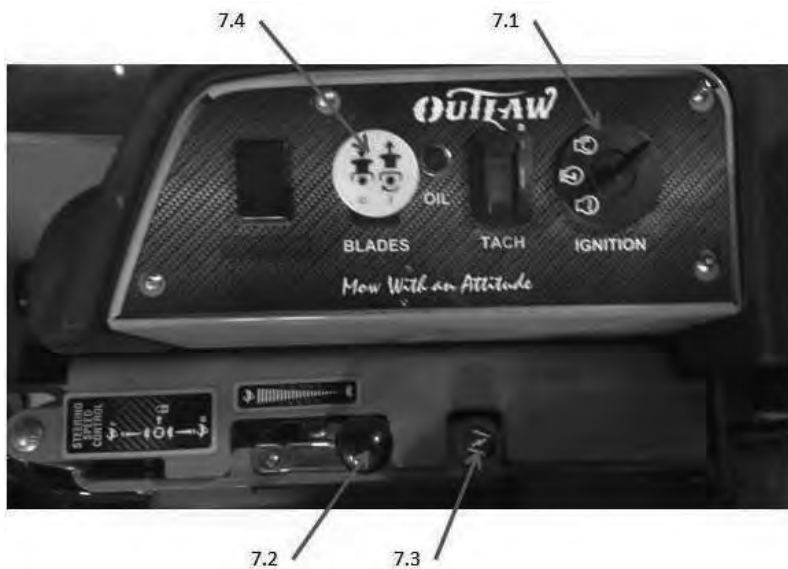



---

## SECTION 8: MOVING INOPERABLE MOWER

- 8.1 Do not tow machine. Use a winch to load on a trailer for transporting.
- 8.2 **ATTENTION:** RETURN BYPASS VALVES TO OPERATING POSITION BEFORE RUNNING MOWER FOLLOWING REPAIRS.
- 8.3 If it becomes necessary to move an inoperable mower, the drive transaxles are equipped with bypass valves that allow the drive tires to rotate freely. These bypass valves are located on top of the Outlaw's transaxles and on the inner side of the Outlaw Extreme's transaxles. Each require a quarter turn to allow for proper bypass.
- 8.4 Your Bad Boy Mower Weighs:      **OUTLAW SERIES:**      **1180—1310 lbs**  
*\*\*\* Weights fluctuate with the addition of accessories.*
- 8.5 As you can see by the weights of the machines, you shouldn't ever try to push or pull a Bad Boy Mower by hand. This could cause serious bodily injury.
- 8.6 Hopefully, you'll never need to use this section of the manual. However, if you do, use extreme caution when moving machine!

## SECTION 9: INSTRUMENTATION

- 9.1 **Electronic Hour Meter**—Registers Hour increments up to 9,999.9 total hours. This meter records the cumulative time the engine is running.
- 9.2 **Oil Light**—Alerts the user of a low oil level situation when lit.

---

## SECTION 10: MOWER BLADE MAINTENANCE

- 10.1 Check mower blades after each use. This is essential for maintaining well-groomed turf. Keep the blades sharp. If a dull blade is used for cutting, the grass will tear rather than cut. This could damage the grass leaving a brown frayed top on the grass within a few hours. A dull blade will also require more power from the engine.
- 10.2 NEVER attempt to straighten a bent blade by heating. NEVER attempt to weld a cracked blade. The blades can break and cause serious injury or death.
- 10.3 NEVER work with blades while engine is running or deck clutch is engaged.
- 10.4 ALWAYS place deck clutch in DISENGAGE position while performing maintenance.
- 10.5 Use blocks when you MUST work under mower.
- 10.6 ALWAYS wear thick gloves when handling blades.
- 10.7 ALWAYS check for blade damage if mower strikes rock, branch, or other objects that could potentially damage the blade.

***(REMEMBER: NEVER CHECK BLADE WHILE ENGINE IS ON!  
NEVER CHECK BLADES WHILE BLADES ARE ENGAGED!)***

## SECTION 11: GREASING THE BEARINGS

- 11.1 Park the machine on a level surface and disengage the blade control switch.
- 11.2 Move the motion control levers outward to the neutral position, engage parking brake, stop the engine, remove the key, and wait for all moving parts to stop before leaving the operating position.
- 11.3 Grease Type: NLGI grade #2 multi-purpose gun grease. Grease the front caster pivots. 11.4 Clean the grease fittings with a cloth. Scrape any paint off the front of the fitting(s).
- 11.5 Connect a grease gun to each fitting. Pump grease in fittings until grease begins to seep out of the bearings. Wipe up excess grease.
- 11.6 Refer to service manual section for grease fitting locations.





---

## HOW TO CHOOSE THE RIGHT BLADE

Essentially there are only TWO basic styles of mowing blades used or approved for use on our current products:

- 1) The standard style of mowing blade is essentially designed for cutting grass and effectively discharging the clippings out from the deck to fall onto the lawn or to be captured in a grass collection system. Standard blades are also referred to as “2-in-1” (discharging & bagging ) or “high-lift” blades (because they are designed to create a higher-lifting airflow).
- 2) Mulching blades generally have a more curved style surface and frequently include extra cutting surfaces along the blade edges. These blades may also come in a “+” design (which is actually two individual blades arranged in a perpendicular fashion to enhance mulching). The “+” blades are usually found on older style mowers; newer ones utilize blades with more advanced mulching technology. Mulching blades may also be referred to as “3-in-1” (mulching, discharging & bagging) or “all-purpose” blades.

Bear in mind that the re-circulating airflow design of 3/1 blades makes them less efficient at discharging grass clippings than a standard 2/1 blade. As with most all-purpose tools, there is some give and take as opposed to using a tool designed for a more specific purpose.

If you’re experiencing less-than-desired cutting or discharging performance with a 3/1 blade, you may want to check into using a 2/1 blade. Conversely, if you’re using a 2/1 blade and want to mulch clippings, you should see about the availability of mulching blades or a mulching kit.\*

The type of blade installed on a new mower is a decision the retailer makes for each model of mower, based on the expected needs of most customers. If you’re unsure of which blade is on a particular model, inspect the blade. Blades have part numbers stamped into them. Then compare these part numbers with the unit’s Operator’s Manual or Parts List.

It is true there are many other styles of blades available. But since we don’t manufacture or recommend using these other aftermarket styles, we will leave them out of this discussion. Should you want more information on special application or aftermarket blades, you should contact the companies that make these products. NOTE: Customers using non-OEM blades do so at their own risk. The use of unapproved (non-OEM) blades may void any or all of the mower and engine factory warranties.

\* **MULCHING KITS** – These generally consist of mulching blades and a mulching plug (which closes off the discharge opening to keep the clippings contained under the deck for re-cutting) plus any necessary hardware for installation. Please check with your parts distributor regarding the contents of a particular mulching kit.

---

## MOWING TIPS:

- Mow header strips at the ends of the lawn and around flower beds first. Make them wide enough that you can turn the mower around in the already mown section. Then mow back and forth between these header strips overlapping each lap by about 1/8 the width of the mower's deck.
- Don't cut your grass too short, particular for cool season grasses. Higher heights usually provide for a deeper root system, looks better, and is less likely to have weeds invading, particularly crabgrass.
- Don't remove any more than one third of the grass leaf at any one cutting. If circumstances arise that a lawn gets too tall and you just have to lop off a bunch to get caught up, bite the bullet and break it down into several mowings to get caught up with 3 or so days between cuttings.
- **NEVER SCALP YOUR LAWN.** Scalping severely damages the root system to such a degree that it may die.
- Avoid mowing when the grass is wet or when it's dark
- Avoid throwing grass clippings into the street and driveway where they can be washed into the sewer system. After mowing, clean up driveway and walkways.
- When mowing remove only a third with each cutting (except for the first mowing of the season when it's ok to remove more). You can safely leave clippings that will quickly decompose and add nutrients back into the soil. Contrary to popular opinion, grass clippings do not add to thatch buildup. Grass blades are made up of about 75% water.
- Mow your lawn in a different direction with each mowing, especially with lawns of shorter grass types. Altering the direction ensures a more even cut since grass blades will grow more erect and less likely to develop into a set pattern.
- Keep your mower's blade sharp, which means having it sharpened several times during the mowing season. Keep several blades around so you'll always have a sharp one on hand. Sharp blades cut the grass cleanly and help mulch clippings into small pieces which break down quickly.
- Don't forget to change your mower's oil at least once during the mowing season. For brand new mowers, change the oil after about 5 hours of operation during the initial break-in period.
- At the end of the mowing season use a fuel stabilizer in the remaining gasoline
- In the spring, don't use that old gas unless you properly used a fuel stabilizer, it can cause a number of problems. Better to use fresh gasoline to begin the new mowing season.
- **Leaf blade A** demonstrates what a leaf blade should look like after mowing with a sharp blade.
- **Leaf blade B** demonstrates a leaf blade that was injured by a dull mower blade.
- **Leaf blade C** was cut by the mower but indicates that the mower blade is not sharp enough. The shredded white tissue protruding from the leaf blades C and D is the vascular tissue of the plant.
- **Leaf blade D** has been mown for quite some time with a dull mower blade.

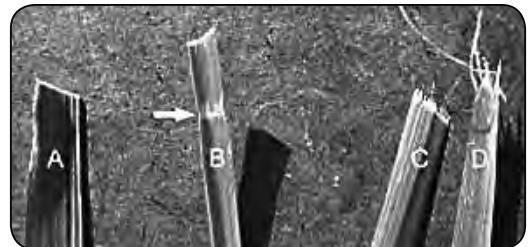

The leading edge of the blade enclosure is equipped with an adjustable guard. When the guard is set to a higher position, it allows incoming grass to remain in a more upright position just prior to being cut. The result is a higher quality cut.

### ***To bag or mulch?***

Grass clippings do not contribute to thatch buildup or increase the chances of disease. If you mow your lawn at the right height, without removing any more than 1/3 of it's total height, clippings will quickly breakdown without a trace. These clippings contribute additional nitrogen and other nutrients to the soil and supply it with additional organic materials. Clippings from a 1000 sq. ft. lawn can add as much as 1 - 2 pounds of nitrogen back into the soil. If you have a compost pile, then you may want to bag your clippings occasionally to add much needed green-matter to the compost pile. Make sure it is mixed thoroughly with brown matter to avoid a strong ammonia odor. **DO NOT COMPOST CLIPPINGS** after applying any weed control or weed-feed type product. Before adding clippings to the compost pile wait at least 3 mowings after these products have been applied.





# SERVICE SECTION

## SECTION 1: HYDROSTATIC SYSTEM

The hydro reservoir tank on the Outlaw model is located on each side of rear cover. Notice the “full cold” line at the bottom of the tank. Use only 20W-50 motor oil in this tank. Conventional or synthetic oil may be used.

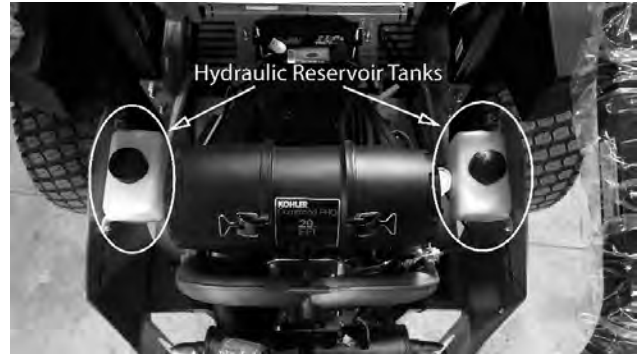

### THE FOLLOWING MAINTENANCE IS TO BE PERFORMED ON A LEVEL SURFACE.

Outlaw transaxles hold 4 quarts of 20W-50 moto oil each. Bad Boy Hydrostatic Oil is recommended. Transaxle service is recommended after the first 75 hours of use; then at intervals of 250 usage hours. Use only Hydro-Gear® brand oil filters. Use of other brands could void the warranty.



### Changing your hydraulic oil and filter Outlaw 4400

- 1) Place an oil drain pan (12” or more in diameter and 8 qt. capacity is optimal) beneath the oil filter. Remove the oil filter cover from the transaxle to drain the oil. Remove the O-ring from the cover and discard the O-ring.
- 2) After the oil has drained from the transaxle, remove the oil filter from the transaxle housing.
- 3) Install a new filter and a new O-ring onto the filter cover and install the filter cover. Torque the filter cover to 200-300 **in-lbs**.
- 4) Fill the transaxle with new 20W-50 motor oil through the hydraulic reservoir until it reaches the cold fill line on the tank.
- 5) Drain the old oil filter of all free flowing oil prior to disposal. Place used oil in appropriate containers and deliver to an approved recycling collection facility.
- 6) Proceed to the purge procedure on the next page.

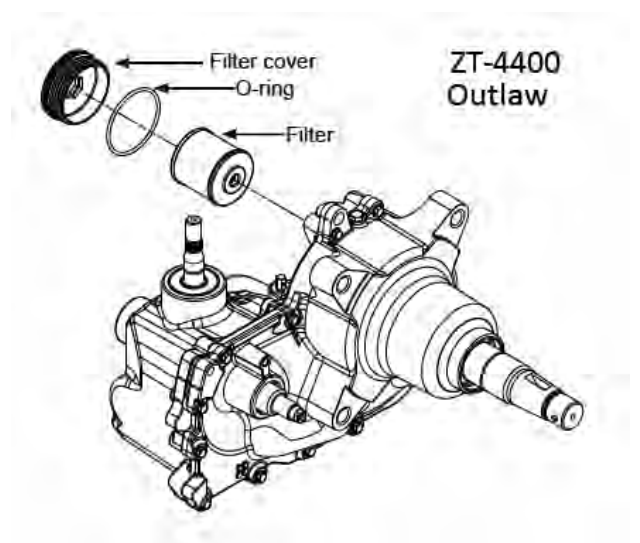

## Purging Procedure

Due to the effects air has on the efficiency in hydrostatic drive applications, it is critical that the air is purged from the system. These purge procedures should be implemented any time a hydrostatic system has been opened to facilitate maintenance or any additional oil has been added to the system.

- 1) Lift the rear tires of the mower off of the ground and chock your front tires so they do not move.
- 2) With the bypass valve open and the engine running, slowly move the directional drive arms in the forward and reverse directions (5 to 6 times), as air is purged from the unit, the oil level will drop.
- 3) With the bypass valve closed and the engine running, slowly move the directional drive arms in the forward and reverse directions (5 to 6 times). Check the oil level, and add oil as required after stopping the engine.
- 4) It may be necessary to repeat steps 1 and 2 until all the air is completely purged from the system. When the transaxle moves forward and reverse at normal speed purging is complete.

Outlaw Extreme transaxles hold 4.75 quarts each. Bad Boy Hydrostatic Oil is recommended. Transaxle service is recommended after the first 75 hours of use; then at intervals of 250 usage hours. Use only Hydro-Gear® brand oil filters. Use of other brands could void the warranty.

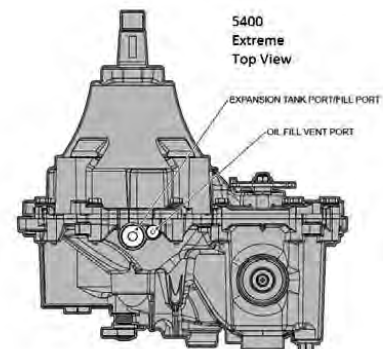
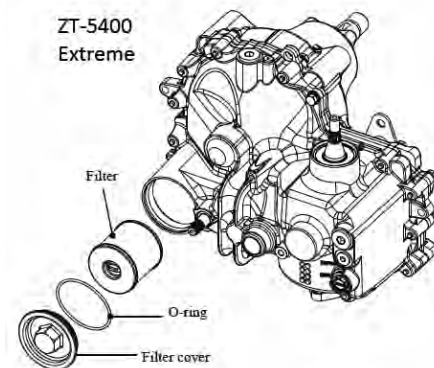
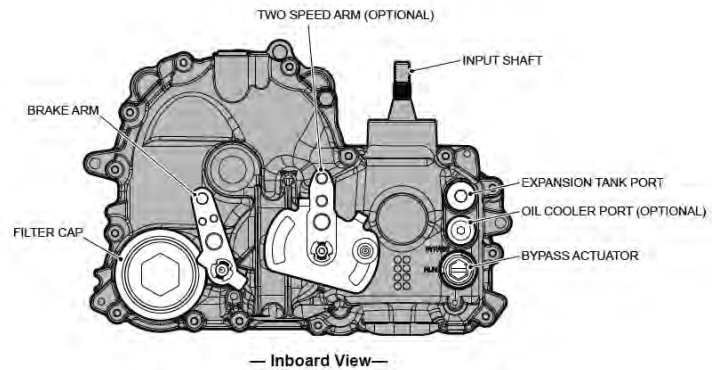

## Changing your hydraulic oil and filter Extreme 5400

- 1) Place an oil drain pan (12" or more in diameter and 8 qt. capacity is optimal) beneath the oil filter. Remove the oil filter cover from the transaxle to drain the oil. Remove the O-ring from the cover and discard the O-ring.
- 2) After the oil has drained from the transaxle, remove the oil filter from the transaxle housing.
- 3) Install a new filter and a new O-ring onto the filter cover and install the filter cover. Torque the filter cover to 200-300 **in-lbs**.
- 4) Remove the top oil fill vent port plug as seen in the picture to the right. Fill the transaxle with new 20W-50 through the hydraulic reservoir tank until the oil reaches the oil fill vent port.
- 5) Install the top oil fill vent port plug and continue filling the system with oil until the fill line is reached in the expansion tank.
- 6) Drain the old oil filter of all free flowing oil prior to disposal. Place used oil in appropriate containers and deliver to an approved recycling collection facility.
- 7) Proceed to the purge procedure below.

### Purging Procedure

Due to the effects air has on the efficiency in hydrostatic drive applications, it is critical that the air is purged from the system. These purge procedures should be implemented any time a hydrostatic system has been opened to facilitate maintenance or any additional oil has been added to the system.

- 1) Lift the rear tires of the mower off of the ground and chock your front tires so they do not move.
- 2) With the bypass valve open and the engine running, slowly move the directional drive arms in the forward and reverse directions (5 to 6 times), as air is purged from the unit, the oil level will drop.
- 3) With the bypass valve closed and the engine running, slowly move the directional drive arms in the forward and reverse directions (5 to 6 times). Check the oil level, and add oil as required after stopping the engine.
- 4) It may be necessary to repeat steps 1 and 2 until all the air is completely purged from the system. When the transaxle moves forward and reverse at normal speed purging is complete.

### EXTERNAL FEATURES ZT-5400 POWERTRAIN®

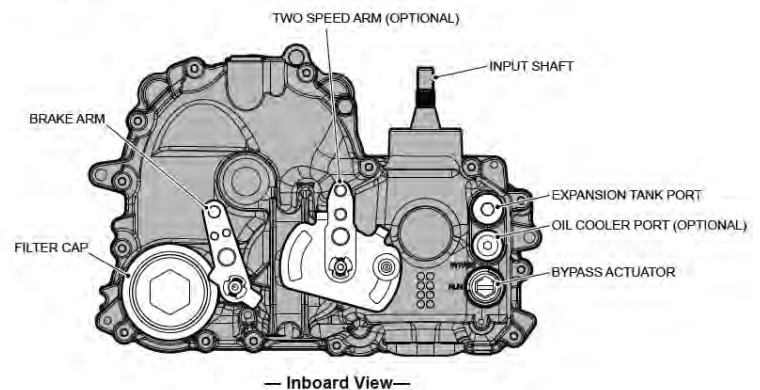

Under the rear of the mower, you will find the two levers shown in the image. These bypass levers serve as a neutral for moving the mower while the engine is not running. Pull the levers out and lock them into place to activate the bypass.

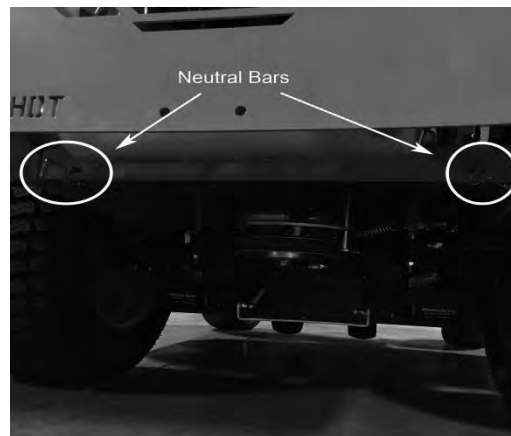

When adjusting the tracking on the mower, the length of the pushrods can be changed by screwing the pivot joint in or out on the ends of the rods. Shortening the overall length of the rod slows the pump down. Lengthening the rod will increase the speed of the pump.

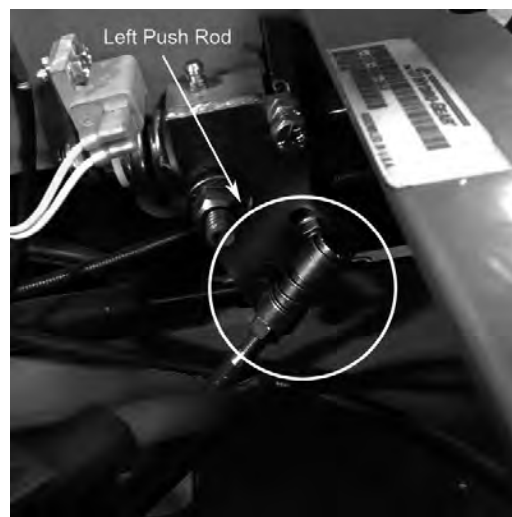

---

## SECTION 2: DRIVE BELT

Shown on the right is the tensioner for your pump belt. Adjusting this will either increase or decrease tension on the belt. Use a  $\frac{3}{4}$ " wrench to loosen the jam nuts and either tighten for more belt tension or loosen for less belt tension.



The belt tension should be set to 60-65 lbs. for the Outlaw.

Use a belt tension gauge to ensure the proper tension. Your dealer or service center will have a belt tension gauge or you can buy one (Part Number 041-9999-00).

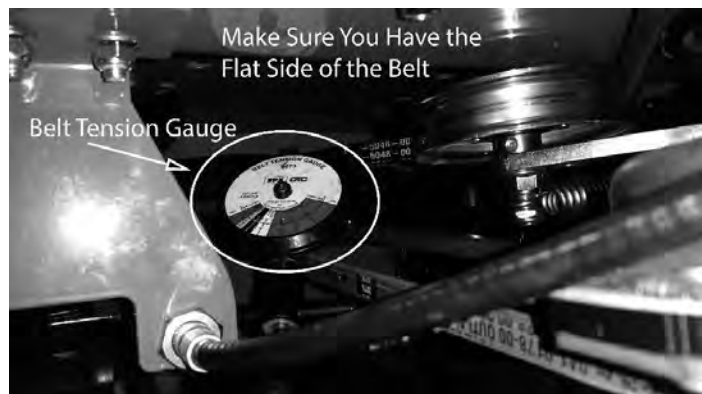



## SECTION 3: ENGINE

### 810CC Vanguard

This machine has an oil drain hose installed on the engine to allow for easier oil changes. Bad Boy recommends that the oil and filter be changed at intervals of 50 usage hours or yearly, whichever occurs first. The oil capacity is 2 quarts. Bad Boy 10W-30 synthetic blend engine oil is recommended for maximum protection.

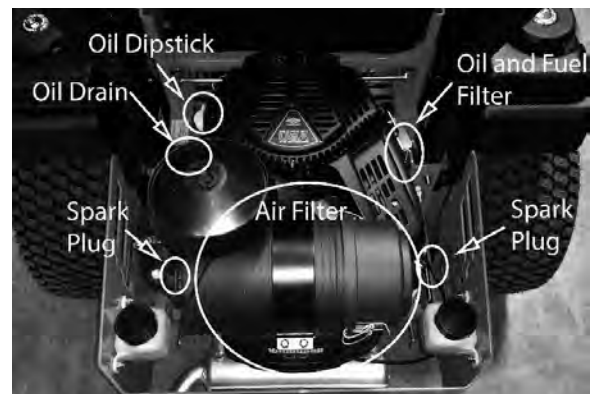

#### 3.1 Changing your engine oil and oil filter

- 1) Remove oil dipstick and open oil drain. Allow oil to completely drain. (Make sure to have an oil pan ready to capture old oil and properly dispose old oil.)
- 2) The oil filter is located on the right side of the engine. Clean area around oil filter. Place a container under the oil filter to capture any oil and remove filter. Wipe off mounting surface and reinstall drain plug. Torque to 10 ft\*lb.
- 3) Place new filter in shallow pan with open end up. Fill with new oil until oil reaches the bottom of the threads. Allow 2 minutes for oil to be absorbed by filter material.
- 4) Apply a thin film of clean oil to rubber gasket on new filter
- 5) Refer to instructions on oil filter for proper installation.
- 6) Fill crankcase with approximately 2 quarts of new oil. Level should top of indicator on dipstick.
- 7) Reinstall oil fill/dipstick and tighten securely.
- 8) Start engine; check for oil leaks. Stop Engine; correct oil leaks. Recheck oil level
- 9) Dispose of used oil and filter in accordance with local ordinances.

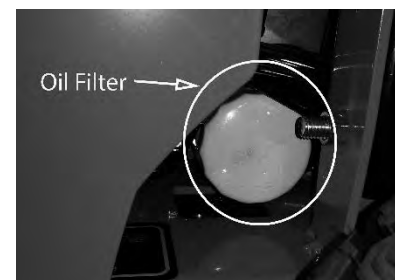
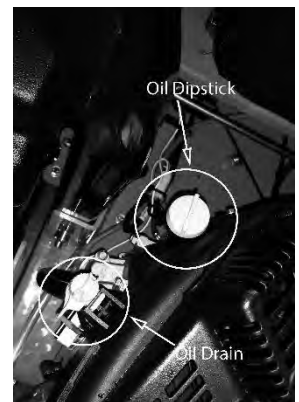



The fuel filter is located in the fuel line about 12" from the carburetor on the side of the engine. Replace the filter yearly. Prior to the removal of the old filter, note the direction of fuel flow as indicated on the filter. Have towels readily available in order to quickly remove any fuel leakage. Always use new hose clamps and ensure the security of the new filter by lightly pulling on each hose. Always perform maintenance outdoors or in a well ventilated area. Do not smoke or allow any open flames in the vicinity of any maintenance activities.

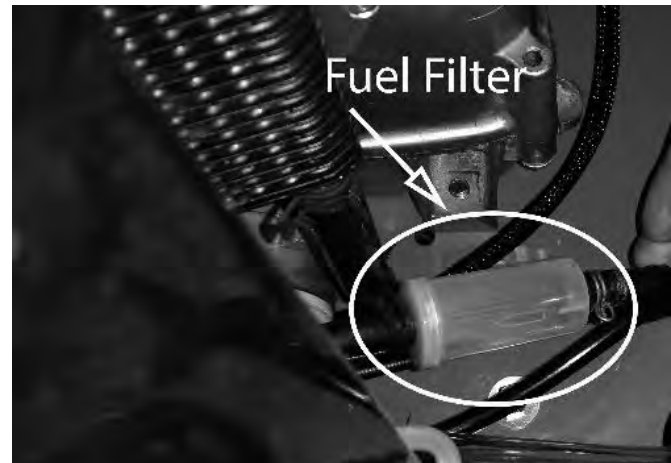

### 3.2 Changing your fuel filter

- 1) Locate your fuel filter and mark the direction it is facing.
- 2) Clamp each side of the fuel filter to minimize and gas spills.
- 3) Remove the clips from each side of the fuel filter and remove the filter.
- 4) Place the new fuel filter in the same direction as the old and place clips back into place and remove clamps.

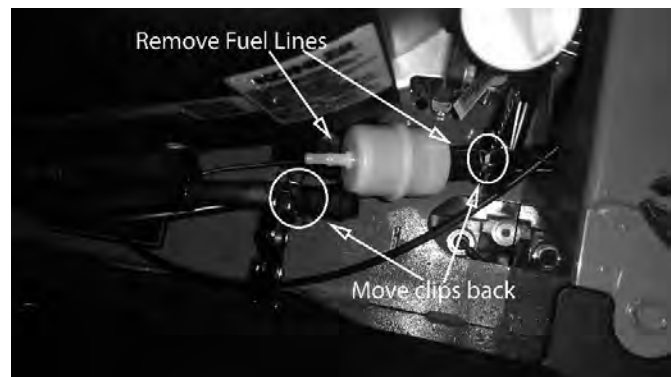

The air cleaner is the engine's only defense against damaging foreign particles. It is very important that the air cleaner element is inspected prior to each use. Remove the element and tap its sides in order to remove debris. Do not blow the filter out using compressed air. Doing so will greatly reduce the air cleaner's effectiveness. Replace yearly; more often in dusty environments. Adhering to these practices will help prevent loss of power and premature engine failure.

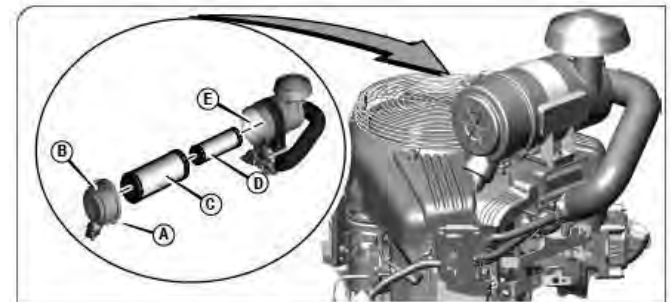

810 Vanguard Air Cleaner Component List			
<b>A</b>	Latches	<b>E</b>	Inner Air Filter
<b>B</b>	Cap	<b>F</b>	Air Intake
<b>C</b>	Outer Air Filter		

### 3.4 Changing the spark plugs and checking the spark plug gap:

- 1) Remove the wire on the spark plug and use a 5/8" socket to remove the spark plug.
- 2) Check the gap on the spark plug to verify that it is 0.03 in using a feeler gauge.
- 3) If the spark plug is worn, overheated, wet or carbon fouled replace the spark plug.
- 4) Install the plug into cylinder head and torque to 20 ft.\*lbs. Be careful not to overtighten the spark plug.

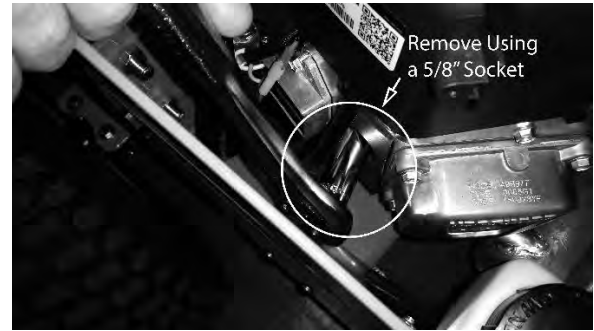
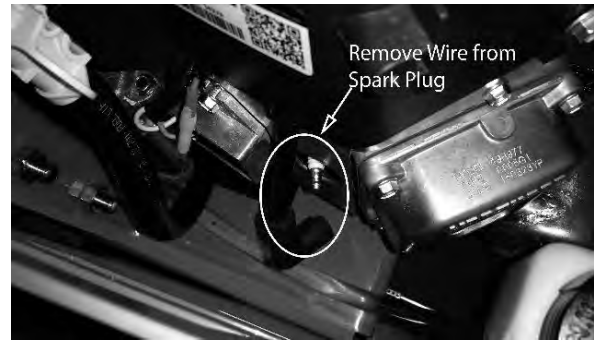

**Spark Plug Component and Details**

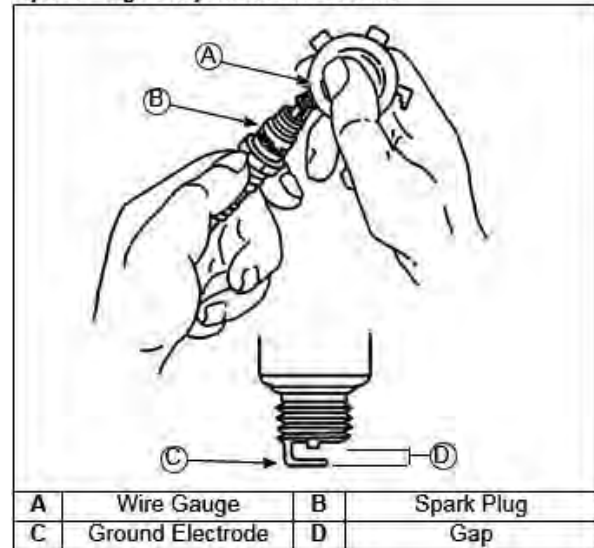

# Kohler Confidant 747CC

This machine has an oil drain hose installed on the engine to allow for easier oil changes. Bad Boy recommends that the oil and filter be changed at intervals of 50 usage hours or yearly, whichever occurs first. The oil capacity is 2 quarts. Bad Boy 10W-30 synthetic blend engine oil is recommended for maximum protection.

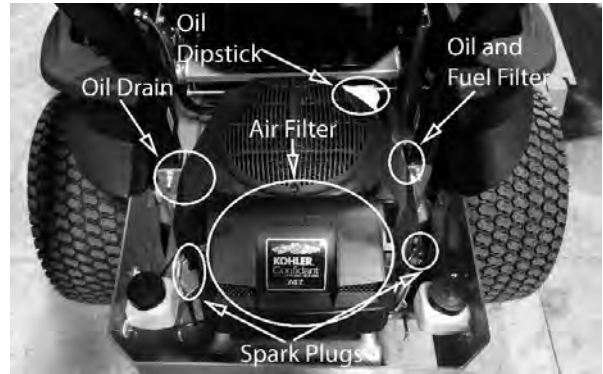

## 3.1 Changing your engine oil and oil filter

1) Remove oil dipstick and open oil drain.

Allow oil to completely drain. (Make sure to have an oil pan ready to capture old oil and properly dispose old oil.)

2) The oil filter is located on the right side of the engine. Clean area around oil filter. Place a container under the oil filter to capture any oil and remove filter. Wipe off mounting surface and reinstall drain plug. Torque to 10 ft\*lb.

3) Place new filter in shallow pan with open end up. Fill with new oil until oil reaches the bottom of the threads. Allow 2 minutes for oil to be absorbed by filter material.

4) Apply a thin film of clean oil to rubber gasket on new filter.

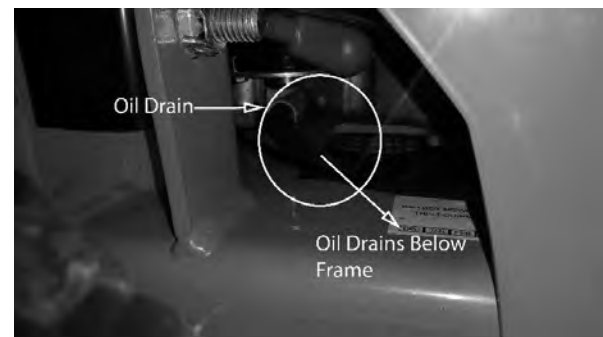

í DÜ^-\ Á Á • d' & cā } • Á } Á qÁc! Á Á! [ ] ^ Á  
 ÁÁÁ • cā cā } È  
 î DÜ/Á/ & cā \ & cā ^ Á á cā }! [ cā cā ^ Á Á ~ cā Á Á  
 ÁÁÁ ^, Á qÁÁ^ Á @ ~ | á Á } Á - Á á cā } Á } Á  
 ÁÁÁ q • cā È  
 ï DÜ q • cā Á qÁ Á q • cā Á q á cā @ } Á ^ & ! ^ È  
 ì DÜ cā } \* q ^ Á & @ & Á } Á qÁ cā • È Ü ] Á ) \* q ^ Á  
 & ! ^ & q qÁ cā • È Ü ^ & @ & Á qÁ cā  
 J DÜ cā ] [ • ^ Á Á • ^ Á qÁ cā á cā / Á Á & q | á cā & Á á cā  
 [ | & q | á cā q & • È

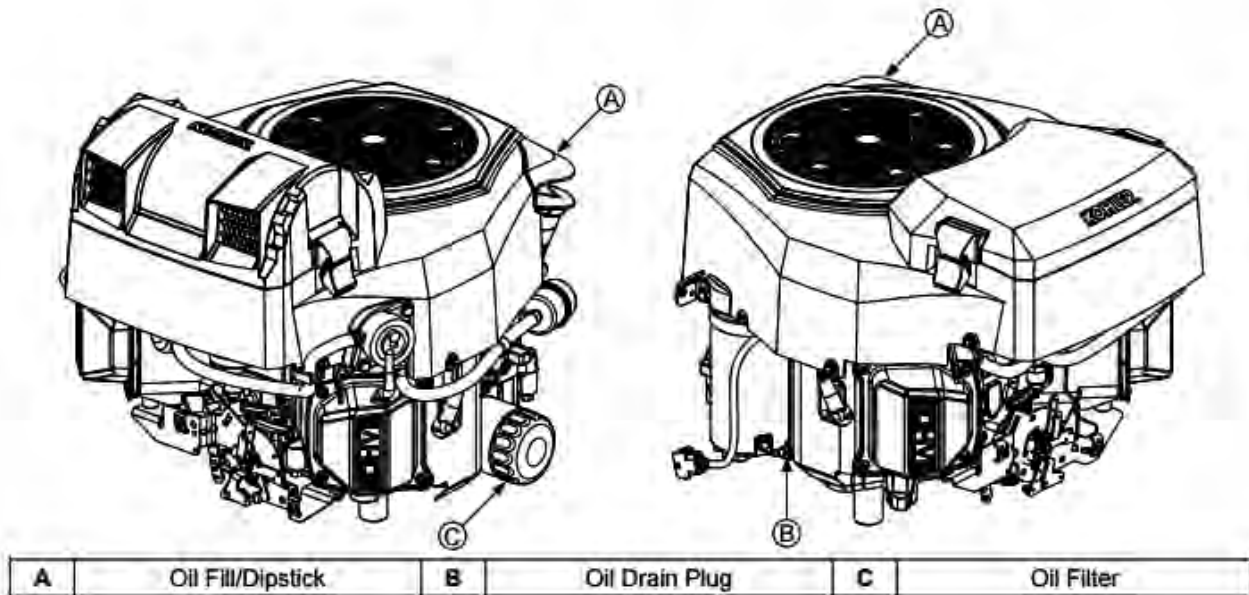

The fuel filter is located in the fuel line about 12" from the carburetor on the side of the engine. Replace the filter yearly. Prior to the removal of the old filter, note the direction of fuel flow as indicated on the filter. Have towels readily available in order to quickly remove any fuel leakage. Always use new hose clamps and ensure the security of the new filter by lightly pulling on each hose. Always perform maintenance outdoors or in a well ventilated area. Do not smoke or allow any open flames in the vicinity of any maintenance activities.

### 3.2 Changing your fuel filter

- 1) Locate your fuel filter and mark the direction it is facing.
- 2) Clamp each side of the fuel filter to minimize and gas spills.
- 3) Remove the clips from each side of the fuel filter and remove the fuel filter.
- 4) Place the new fuel filter in the same direction as the old and place clips back into place and remove clamps.

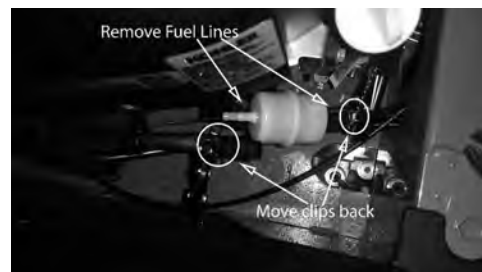
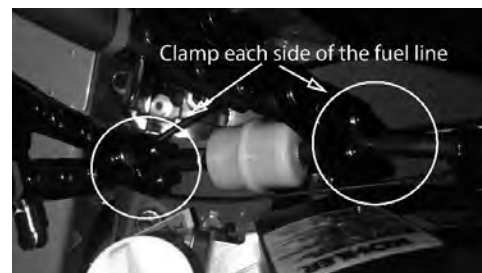

The air cleaner is the engine's only defense against damaging foreign particles. It is very important that the air cleaner element is inspected prior to each use. Remove the element and tap its sides in order to remove debris. Do not blow the filter out using compressed air. Doing so will greatly reduce the air cleaner's effectiveness. Replace yearly; more often in dusty environments. Adhering to these practices will help prevent loss of power and premature engine failure.

### 3.3 Changing the air cleaner

- 1) **Unlock the air cleaner cover and remove to access the air cleaner.**
- 2) **Remove the paper element and pre-cleaner.**
- 3) **Replace or wash pre-cleaner in warm water with detergent. Rinse and allow to air dry.**
- 4) **Lightly oil pre-cleaner with new engine oil; squeeze out excess oil.**
- 5) **Replace paper element and place pre-cleaner onto new paper element.**
- 6) **Install onto base and place cover back on and lock into place.**

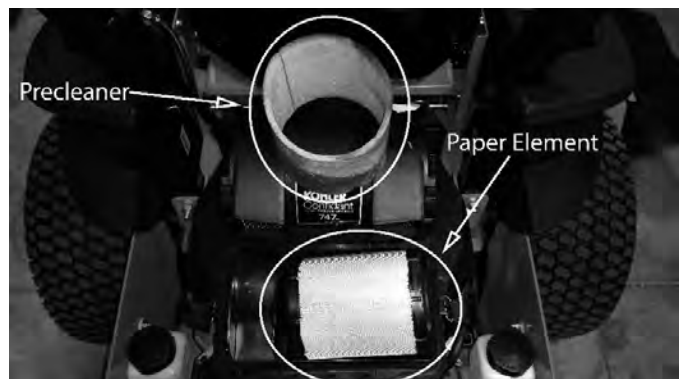
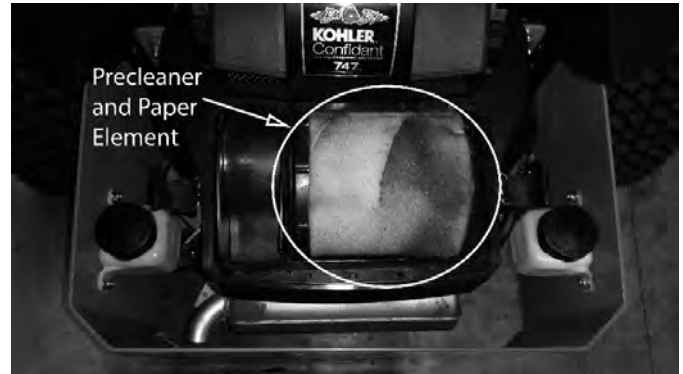

3.4 Changing the spark plugs and checking the spark plug gap:

- 1) Remove the wire on the spark plug and use a 5/8" socket to remove the spark plug.
- 2) Check the gap on the spark plug to verify that it is 0.03 in using a feeler gauge.
- 3) If the spark plug is worn, overheated, wet or carbon fouled replace the spark plug.
- 4) Install the plug into cylinder head and torque to 20 ft\*lbs. Be careful not to overtighten the spark plug.

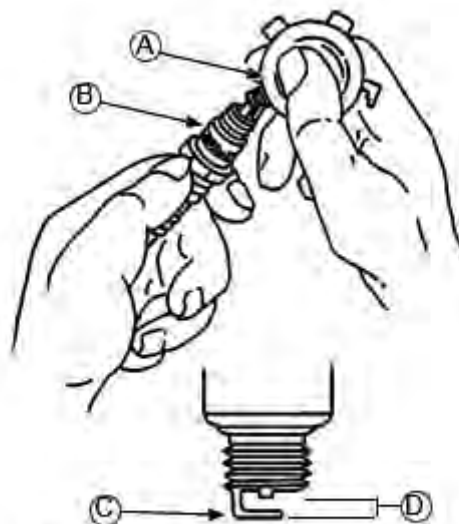
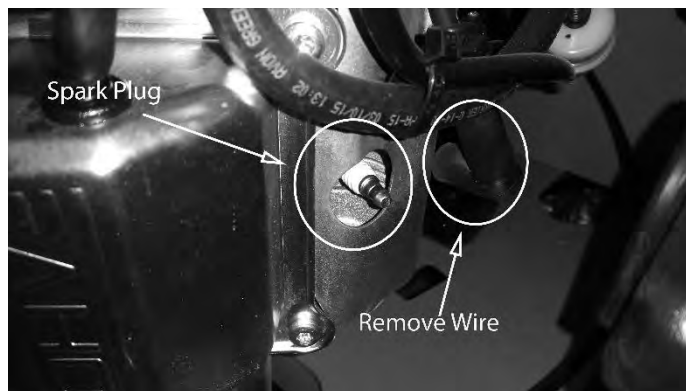

A	Wire Gauge	B	Spark Plug
C	Ground Electrode	D	Gap

# Kawasaki FX730V

This machine has an oil drain hose installed on the engine to allow for easier oil changes. Bad Boy recommends that the oil and filter be changed at intervals of 50 usage hours or yearly, whichever occurs first. The oil capacity is 2 quarts. Bad Boy 10W-30 synthetic blend engine oil is recommended for maximum protection.

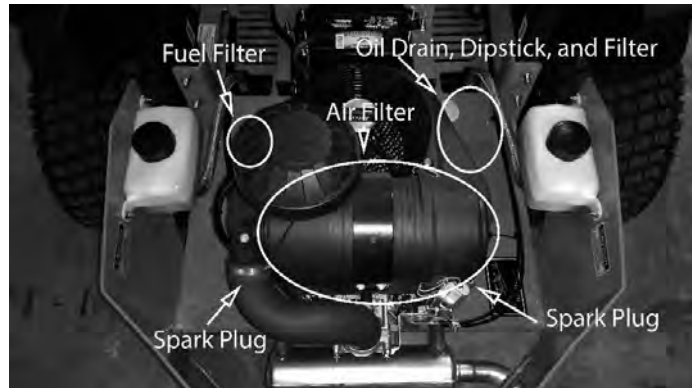

## 3.1 Changing your engine oil and oil filter

- 1) Remove oil dipstick and open oil drain using a 10 mm socket or a flat head screwdriver until oil begins flowing. Allow oil to completely drain. (Make sure to have an oil pan ready to capture old oil and properly dispose old oil.)
- 2) The oil filter is located on the right side of the engine. Clean area around oil filter. Place a container under the oil filter to capture any oil and remove filter. Wipe off mounting surface and reinstall drain plug. Torque to 10 ft\*lb.
- 3) Place new filter in shallow pan with open end up. Fill with new oil until oil reaches the bottom of the threads. Allow 2 minutes for oil to be absorbed by filter material.
- 4) Apply a thin film of clean oil to rubber gasket on new filter
- 5) Refer to instructions on oil filter for proper installation.
- 6) Fill crankcase with approximately 2 quarts of new oil. Level should top of indicator on dipstick.
- 7) Reinstall oil fill/dipstick and tighten securely.
- 8) Start engine; check for oil leaks. Stop Engine; correct oil leaks. Recheck oil level
- 9) Dispose of used oil and filter in accordance with local ordinances.

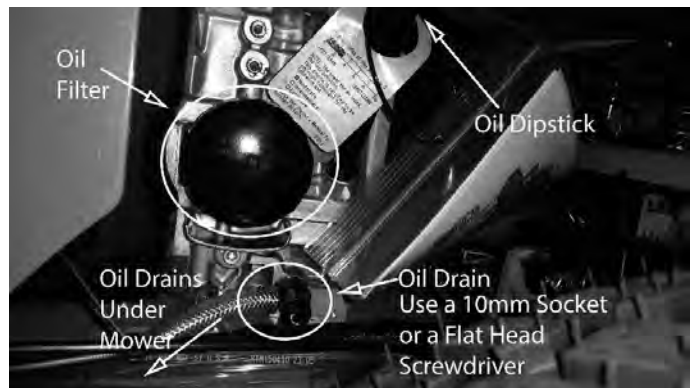

### Parts Location

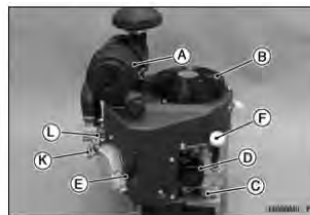

- A. Air Cleaner
- B. Air Inlet Guard
- C. Oil Drain Plug
- D. Oil Filter
- E. Spark Plugs/Spark Plug Caps
- F. Oil Gauge
- K. Control Panel
- L. Carburetor



- G. Fuel Pump
- H. Fuel Filter
- I. Electric Starter
- J. Voltage Regulator

The fuel filter is located in the fuel line on the left side of the engine by the starter motor. Replace the filter yearly. Prior to the removal of the old filter, note the direction of fuel flow as indicated on the filter. Have towels readily available in order to quickly remove any fuel leakage. Always use new hose clamps and ensure the security of the new filter by lightly pulling on each hose. Always perform maintenance outdoors or in a well ventilated area. Do not smoke or allow any open flames in the vicinity of any maintenance activities.

### 3.2 Changing your fuel filter

- 1) Locate your fuel filter and mark the direction it is facing.
- 2) Clamp each side of the fuel filter to minimize and gas spills.
- 3) Remove the clips from each side of the fuel filter and remove the fuel filter.
- 4) Place the new fuel filter in the same direction as the old and place clips back into place and remove clamps.

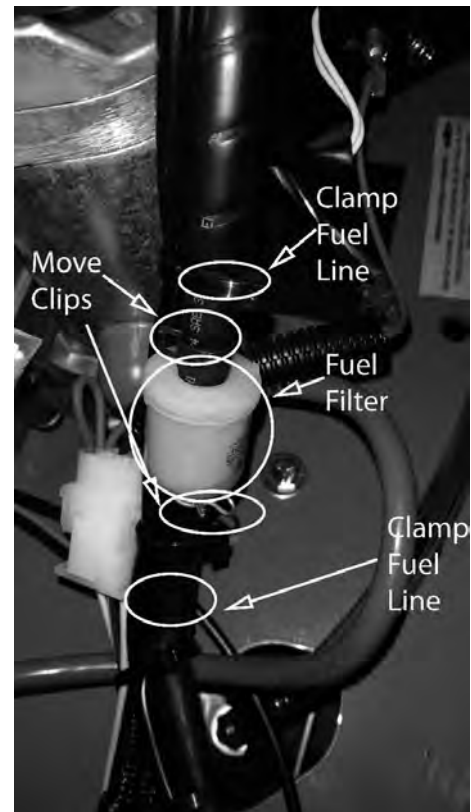

The air cleaner is the engines only defense against damaging foreign particles. It is very important that the air cleaner element is inspected prior to each use. Remove the element and tap its sides in order to remove debris. Do not blow the filter out using compressed air. Doing so will greatly reduce the air cleaner's effectiveness. Replace yearly; more often in dusty environments. Adhering to these practices will help prevent loss of power and premature engine failure.

### 3.3 Changing the air cleaner

- 1) Locate the air filter and unbuckle the air filter cover.
- 2) Remove the cover and take out the outer white element and the inner blue element.
- 3) Clean or replace elements.
- 4) Reattach the cover making sure the air intake is facing down.

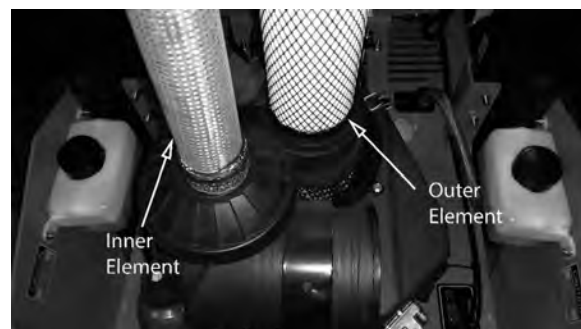
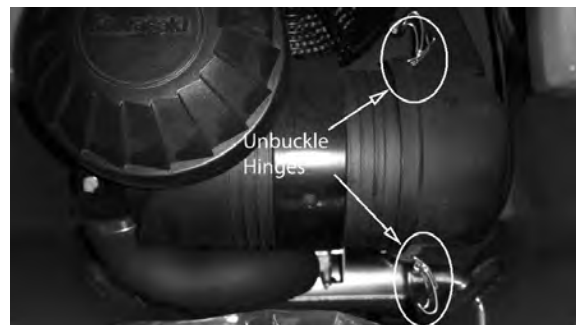



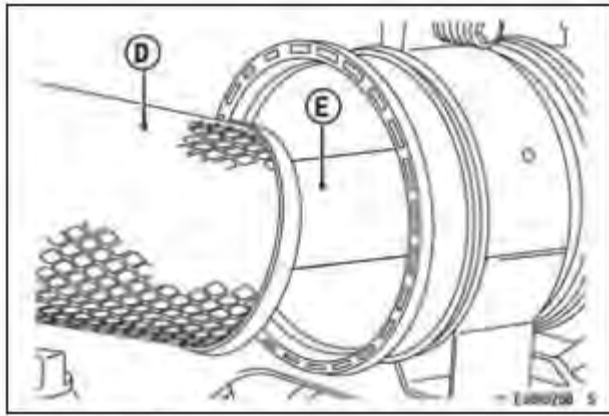

**D. Primary Element**  
**E. Secondary Element**

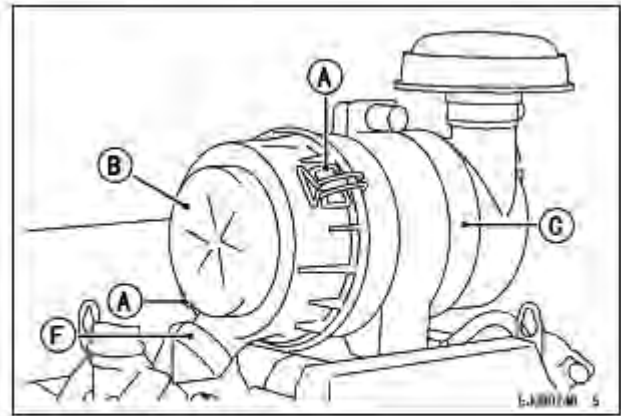

**A. Retaining Clamps**  
**B. Case**  
**C. Air Cleaner Body**  
**F. Cap (Dust Ejector Valve)**

3.4 Changing the spark plugs and checking the spark plug gap:

- 1) Remove the wire on the spark plug and use a 13/16" socket to remove the spark plug.
- 2) Check the gap on the spark plug to verify that it is 0.03 in using a feeler gauge.
- 3) If the spark plug is worn, overheated, wet or carbon fouled replace the spark plug.
- 4) Install the plug into cylinder head and torque to 16 ft.\*lbs. Be careful not to overtighten the spark plug.

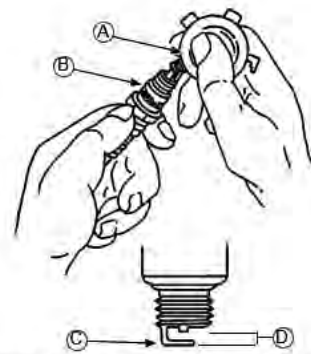

<b>A</b>	Wire Gauge	<b>B</b>	Spark Plug
<b>C</b>	Ground Electrode	<b>D</b>	Gap

# Engines

## Kohler Command Pro EFI ECV870

This machine has an oil drain hose installed on the engine to allow for easier oil changes. Bad Boy recommends that the oil and filter be changed at intervals of 50 usage hours or yearly, whichever occurs first. The oil capacity is 2 quarts. Bad Boy 10W-30 synthetic blend engine oil is recommended for maximum protection.

### 3.1 Changing your engine oil and oil filter

- 1) Remove oil dipstick and open oil drain. Allow oil to completely drain. (Make sure to have an oil pan ready to capture old oil and properly dispose old oil.)
- 2) The oil filter is located on the right side of the engine. Clean area around oil filter. Place a container under the oil filter to capture any oil and remove filter. Wipe off mounting surface and reinstall drain plug. Torque to 10 ft.\*lb. Place new filter in shallow pan with open end up. Fill with new oil until oil reaches the bottom of the threads. Allow 2 minutes for oil to be absorbed by filter material.
- 3) Apply a thin film of clean oil to rubber gasket on new filter
- 4) Refer to instructions on oil filter for proper installation.
- 5) Fill crankcase with approximately 2 quarts of new oil. Level should top of indicator on dipstick.
- 6) Reinstall oil fill/dipstick and tighten securely.
- 7) Start engine; check for oil leaks. Stop Engine; correct oil leaks. Re-check oil level
- 8) Dispose of used oil and filter in accordance with local ordinances.

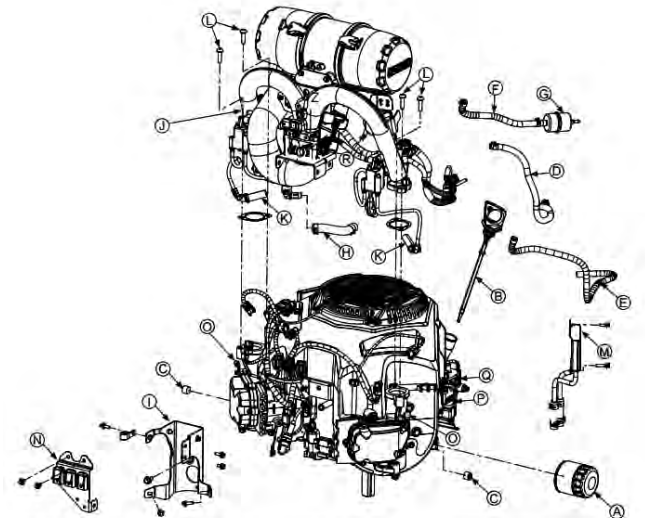

A	Oil Filter	B	Dipstick	C	Oil Drain Plug	D	High Pressure Fuel Line
E	Pulse Line	F	Low Pressure Fuel Line	G	Fuel Filter	H	Breather Hose
I	Throttle Body Bracket	J	Manifold Assembly	K	Spark Plug Lead	L	Manifold Screw
M	Oil Cooler	N	Fuse Holder Bracket	O	J-Clip	P	Clamp
Q	Fuel Pump Module (FPM)	R	Fuel Pump				

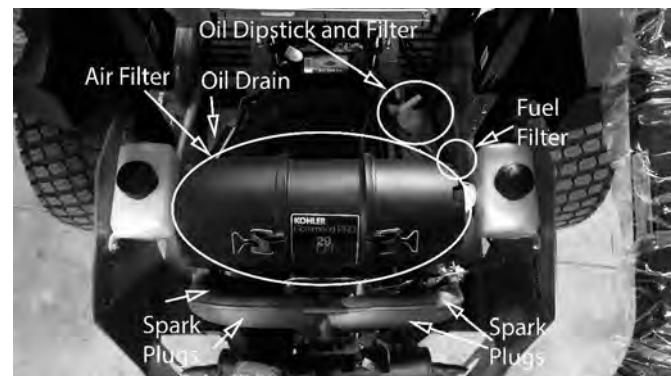

The fuel filter is located in the fuel line about 12" from the carburetor on the side of the engine. Replace the filter yearly. Prior to the removal of the old filter, note the direction of fuel flow as indicated on the filter. Have towels readily available in order to quickly remove any fuel leakage. Always use new hose clamps and ensure the security of the new filter by lightly pulling on each hose. Always perform maintenance outdoors or in a well ventilated area. Do not smoke or allow any open flames in the vicinity of any maintenance activities.

### 3.2 Changing your fuel filter

- 1) Locate your fuel filter and mark the direction it is facing.
- 2) Clamp each side of the fuel filter to minimize and gas spills.
- 3) Remove the clips from each side of the fuel filter and remove the fuel filter.
- 4) Place the new fuel filter in the same direction as the old and place clips back into place and remove clamps.

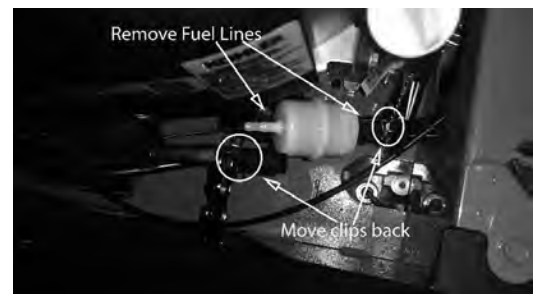
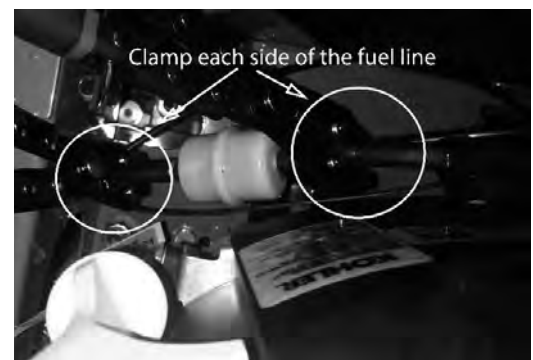

The air cleaner is the engine's only defense against damaging foreign particles. It is very important that the air cleaner element is inspected prior to each use. Remove the element and tap its sides in order to remove debris. Do not blow the filter out using compressed air. Doing so will greatly reduce the air cleaner's effectiveness. Replace yearly; more often in dusty environments. Adhering to these practices will help prevent loss of power and premature engine failure.

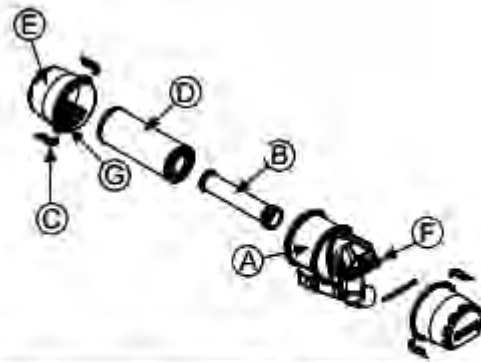

<b>A</b>	<b>Air Cleaner Housing</b>	<b>B</b>	<b>Inner Element (if equipped)</b>
<b>C</b>	<b>Retaining Clip</b>	<b>D</b>	<b>Element</b>
<b>E</b>	<b>End Cap</b>	<b>F</b>	<b>Inlet Screen</b>
<b>G</b>	<b>Ejector Area</b>		

### 3.3 Changing the air cleaner

- 1) Unlock the air cleaner cover and remove to access the air cleaner.
- 2) Remove the air filter element.
- 3) Inspect the air filter element and either clean or replace the element.
- 4) Install onto base and place cover back on and lock into place.

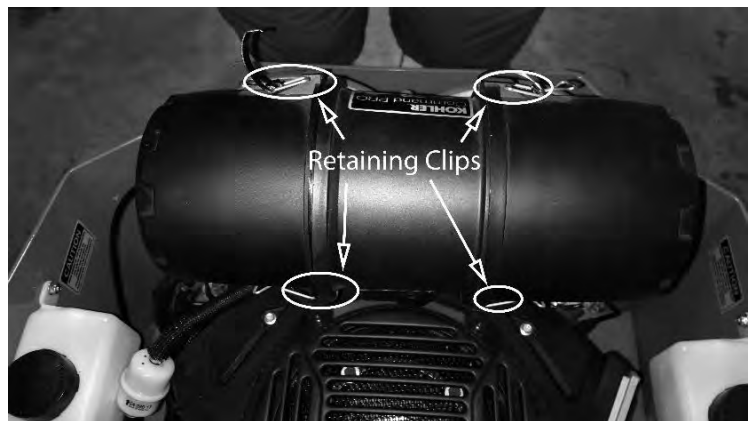

3.4 Changing the spark plugs and checking the spark plug gap:

- 1) Remove the wire on the spark plug and use a 5/8" socket to remove the spark plug.
- 2) Check the gap on the spark plug to verify that it is 0.03 in using a feeler gauge.
- 3) If the spark plug is worn, overheated, wet or carbon fouled replace the spark plug. The Kohler Command Pro EFI ECV870 has a different spark plug than all other Kohlers. The part number is 015-8002-00
- 4) Install the plug into cylinder head and torque to 20 ft.\*lbs. Be careful not to overtighten the spark plug.

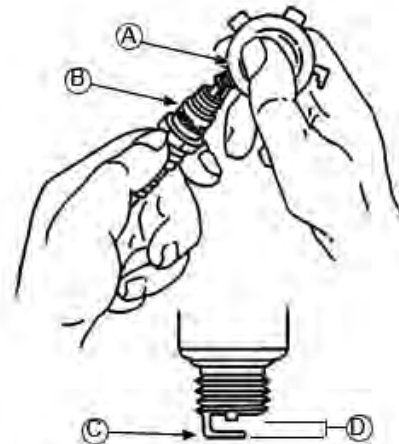
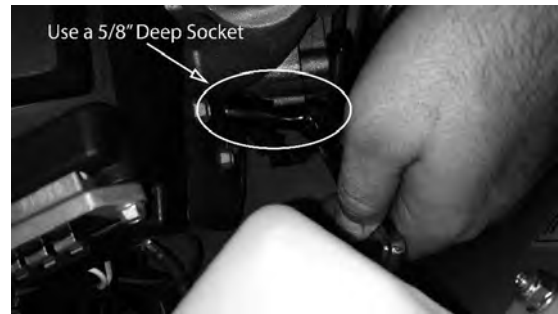

<b>A</b>	Wire Gauge	<b>B</b>	Spark Plug
<b>C</b>	Ground Electrode	<b>D</b>	Gap

# Kawasaki FX850V

This machine has an oil drain hose installed on the engine to allow for easier oil changes. Bad Boy recommends that the oil and filter be changed at intervals of 50 usage hours or yearly, whichever occurs first. The oil capacity is 2 quarts. Bad Boy 10W-30 synthetic blend engine oil is recommended for maximum protection.

## 3.1 Changing your engine oil and oil filter

- 1) Remove oil dipstick and open oil drain using a 10 mm socket or a flat head screwdriver until oil begins flowing. Allow oil to completely drain.  
(Make sure to have an oil pan ready to capture old oil and properly dispose old oil.)
- 2) The oil filter is located on the right side of the engine. Clean area around oil filter. Place a container under the oil filter to capture any oil and remove filter. Wipe off mounting surface and reinstall drain plug. Torque to 10 ft.\*lb.
- 3) Place new filter in shallow pan with open end up. Fill with new oil until oil reaches the bottom of the threads. Allow 2 minutes for oil to be absorbed by filter material.
- 4) Apply a thin film of clean oil to rubber gasket on new filter
- 5) Refer to instructions on oil filter for proper installation.
- 6) Fill crankcase with approximately 2 quarts of new oil. Level should top of indicator on dipstick.
- 7) Reinstall oil fill/dipstick and tighten securely.
- 8) Start engine; check for oil leaks. Stop Engine; correct oil leaks. Recheck oil level.
- 9) Dispose of used oil and filter in accordance with local ordinances.

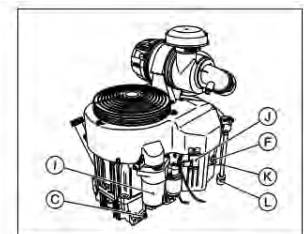
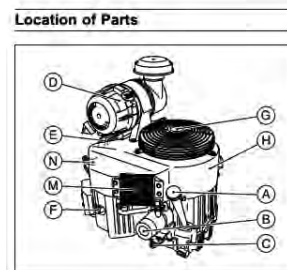
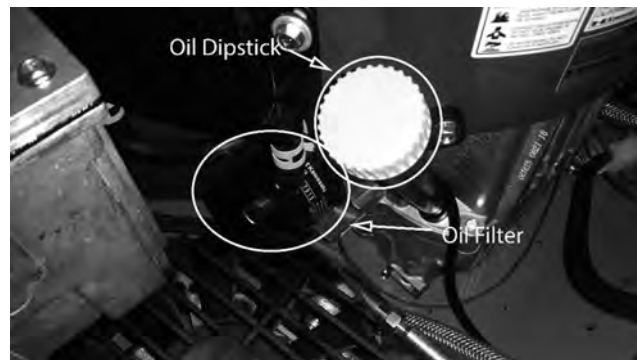

- A. Oil Gauge Filler
- B. Oil Filter
- C. Oil Drain Plug
- D. Air Cleaner
- E. Carburetor
- F. Spark Plug Cap/Spark Plug
- G. Guard
- H. Fan Housing
- I. Electric Starter
- J. Voltage Regulator
- K. Fuel Tube
- L. Fuel Filter
- M. Oil Cooler
- N. Control Panel

The fuel filter is located in the fuel line on the left side of the engine by the starter motor. Replace the filter yearly. Prior to the removal of the old filter, note the direction of fuel flow as indicated on the filter. Have towels readily available in order to quickly remove any fuel leakage. Always use new hose clamps and ensure the security of the new filter by lightly pulling on each hose. Always perform maintenance outdoors or in a well ventilated area. Do not smoke or allow any open flames in the vicinity of any maintenance activities.

### 3.2 Changing your fuel filter

- 1) Locate your fuel filter and mark the direction it is facing.
- 2) Clamp each side of the fuel filter to minimize and gas spills.
- 3) Remove the clips from each side of the fuel filter and remove the fuel filter.
- 4) Place the new fuel filter in the same direction as the old and place clips back into place and remove clamps.

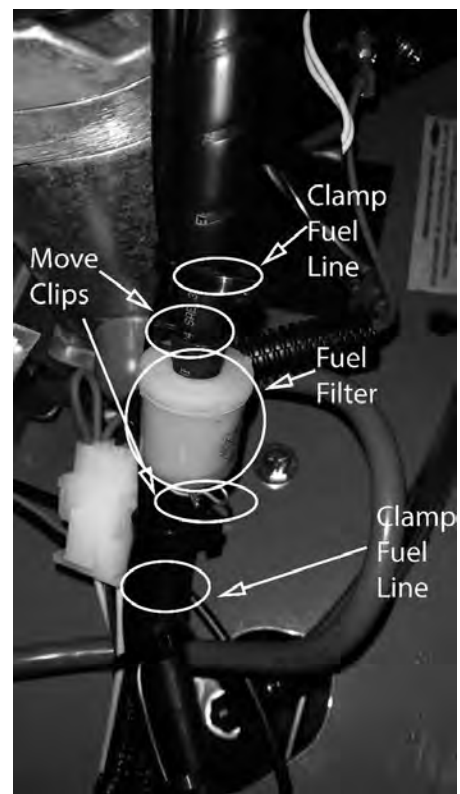

The air cleaner is the engine's only defense against damaging foreign particles. It is very important that the air cleaner element is inspected prior to each use. Remove the element and tap its sides in order to remove debris. Do not blow the filter out using compressed air. Doing so will greatly reduce the air cleaner's effectiveness. Replace yearly; more often in dusty environments. Adhering to these practices will help prevent loss of power and premature engine failure.

### 3.3 Changing the air cleaner

- 1) Locate the air filter and unbuckle the air filter cover.
- 2) Remove the cover and take out the outer white element and the inner blue element.
- 3) Clean or replace elements.
- 4) Reattach the cover making sure the air intake is facing down.

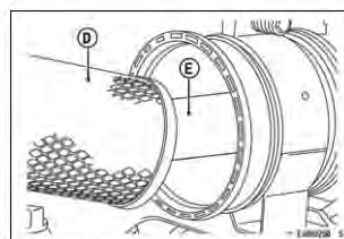
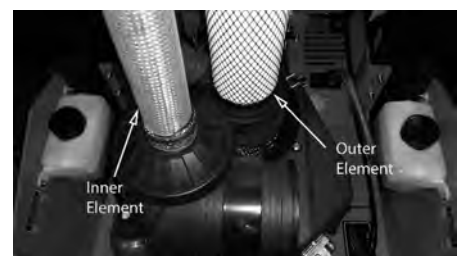
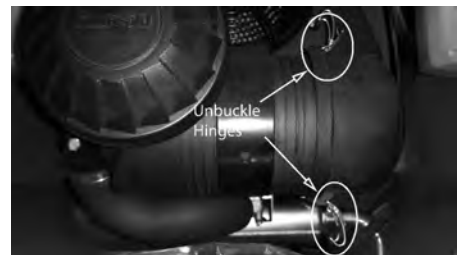

D. Primary Element  
E. Secondary Element

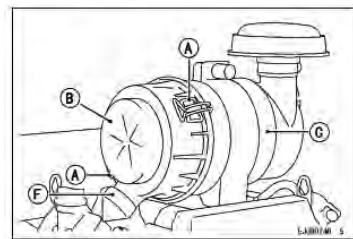

A. Retaining Clamps  
B. Case  
C. Air Cleaner Body  
F. Cap (Dust Ejector Valve)

### 3.4 Changing the spark plugs and checking the spark plug gap:

- 1) Remove the wire on the spark plug and use a 13/16" socket to remove the spark plug.
- 2) Check the gap on the spark plug to verify that it is 0.03 in using a feeler gauge.
- 3) If the spark plug is worn, overheated, wet or carbon fouled replace the spark plug.
- 4) Install the plug into cylinder head and torque to 16 ft.\*lbs. Be careful not to overtighten the spark plug.

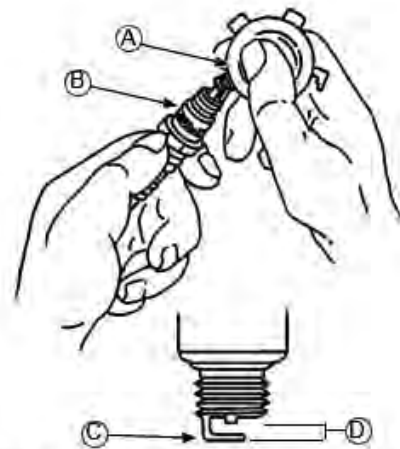

A	Wire Gauge	B	Spark Plug
C	Ground Electrode	D	Gap



# 993cc Vanguard

This machine has an oil drain hose installed on the engine to allow for easier oil changes. Bad Boy recommends that the oil and filter be changed at intervals of 50 usage hours or yearly, whichever occurs first. The oil capacity is 2 quarts. Bad Boy 10W-30 synthetic blend engine oil is recommended for maximum protection.

## 3.1 Changing your engine oil and oil filter

- 1) Remove oil fill cap and open oil drain. Allow oil to completely drain. (Make sure to have an oil pan ready to capture old oil and properly dispose old oil.)
- 2) The oil filter is located on the right side of the engine. Clean area around oil filter. Place a container under the oil filter to capture any oil and remove filter. Wipe off mounting surface and reinstall drain plug. Torque to 10 ft\*lb.
- 3) Place new filter in shallow pan with open end up. Fill with new oil until oil reaches the bottom of the threads. Allow 2 minutes for oil to be absorbed by filter material.
- 4) Apply a thin film of clean oil to rubber gasket on new filter
- 5) Refer to instructions on oil filter for proper installation.
- 6) Fill crankcase with approximately 2 quarts of new oil. Level should top of indicator on dipstick.
- 7) Reinstall oil fill/dipstick and tighten securely.
- 8) Start engine; check for oil leaks. Stop Engine; correct oil leaks. Recheck oil level
- 9) Dispose of used oil and filter in accordance with local ordinances.

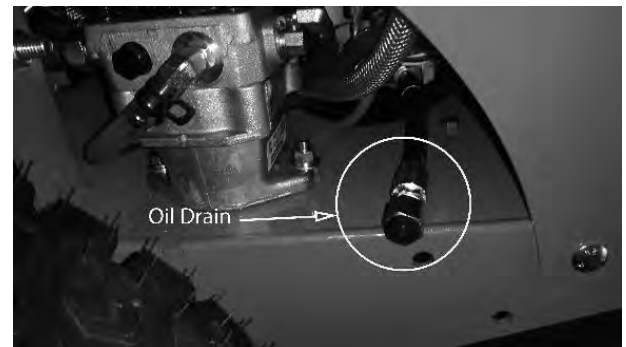

The fuel filter is located in the fuel line about 12" from the carburetor on the side of the engine. Replace the filter yearly. Prior to the removal of the old filter, note the direction of fuel flow as indicated on the filter. Have towels readily available in order to quickly remove any fuel leakage. Always use new hose clamps and ensure the security of the new filter by lightly pulling on each hose. Always perform maintenance outdoors or in a well ventilated area. Do not smoke or allow any open flames in the vicinity of any maintenance activities.

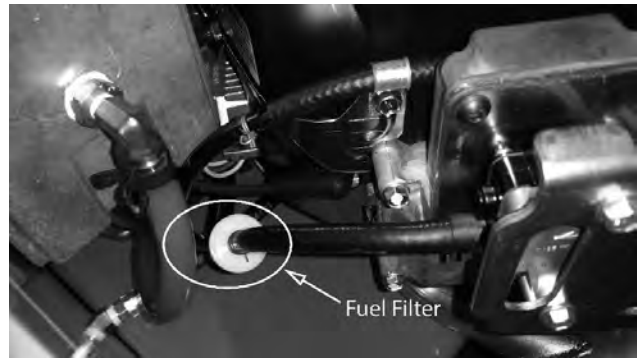

### 3.2 Changing your fuel filter

- 1) Locate your fuel filter and mark the direction it is facing.
- 2) Clamp each side of the fuel filter to minimize and gas spills.
- 3) Remove the clips from each side of the fuel filter and remove the fuel filter.
- 4) Place the new fuel filter in the same direction as the old and place clips back into place and remove clamps.

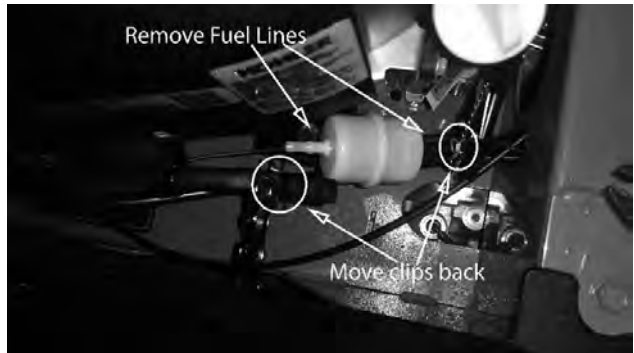

The air cleaner is the engine's only defense against damaging foreign particles. It is very important that the air cleaner element is inspected prior to each use. Remove the element and tap its sides in order to remove debris. Do not blow the filter out using compressed air. Doing so will greatly reduce the air cleaner's effectiveness. Replace yearly; more often in dusty environments. Adhering to these practices will help prevent loss of power and premature engine failure.

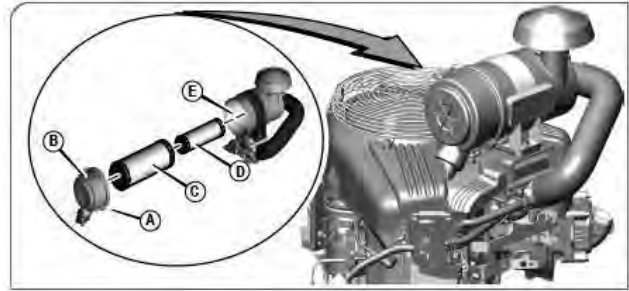

993 Vanguard Air Cleaner Component List	
A	Latches
B	Cap
C	Outer Air Filter
D	Inner Air Filter
E	Air Intake

### 3.3 Changing the air cleaner

- 1) Unlock the air cleaner cover and remove to access the air cleaner.
  
- 2) Remove the outer and inner air filters.
  
- 3) Replace inner and outer filter then place the inner filter into the air intake followed by fitting the outer filter over the inner filter.
  
- 4) Place cap back on and close the latches.

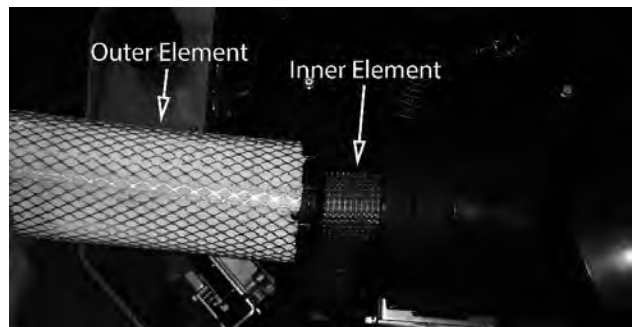

### 3.4 Changing the spark plugs and checking the spark plug gap:

- 1) Remove the wire on the spark plug and use a 5/8" socket to remove the spark plug.
- 2) Check the gap on the spark plug to verify that it is 0.03 in using a feeler gauge.
- 3) If the spark plug is worn, overheated, wet or carbon fouled replace the spark plug.
- 4) Install the plug into cylinder head and torque to 20 ft.\*lbs. Be careful not to overtighten the spark plug.

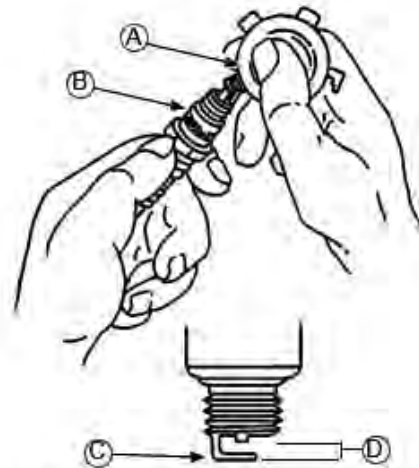
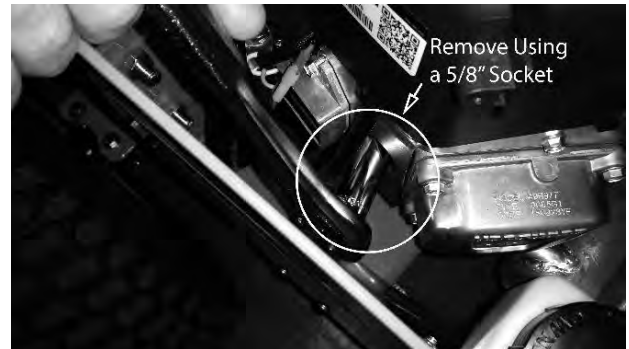
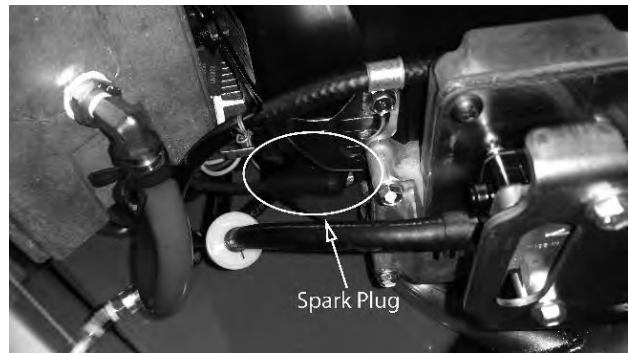

<b>A</b>	Wire Gauge	<b>B</b>	Spark Plug
<b>C</b>	Ground Electrode	<b>D</b>	Gap

---

## SECTION 4: ELECTRICAL SYSTEM

This mower is equipped with one protective fuse: a 30 amp main fuse (pictured to the right).

A blown fuse usually indicates a problem within the electrical system or an electrical component. Ensure the battery terminals are tightly fastened. Never replace a fuse with one of a higher amperage rating or 'bypass' a fuse in any way. Doing so creates a significant fire hazard and can cause severe damage to the mower's electrical components. If a fuse is repeatedly blowing, contact your Bad Boy dealer.

On most models, the red wire coming out of the engine is the charging wire from the alternator. Check for 13.6- 14.2 volts dc at this wire with engine at full throttle.

If you are having issues starting your mower ensure the signal wire is connected to your starter solenoid.

Check the condition and connection of the relays located under the control panel. Ensure that they are clean and connected. Make sure that wire terminal ends have not been pushed out of the relay block.

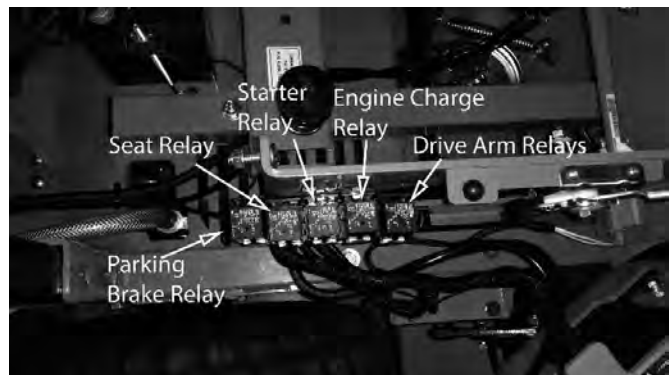
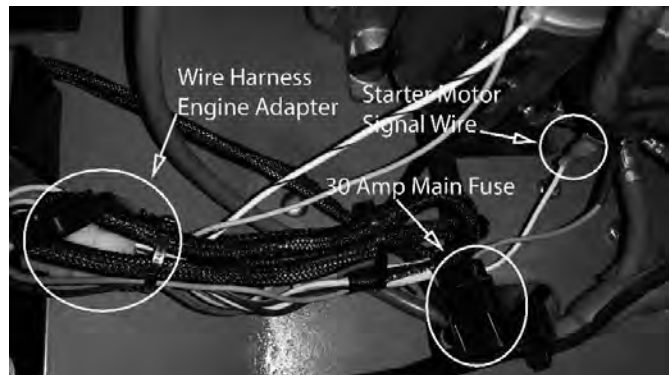

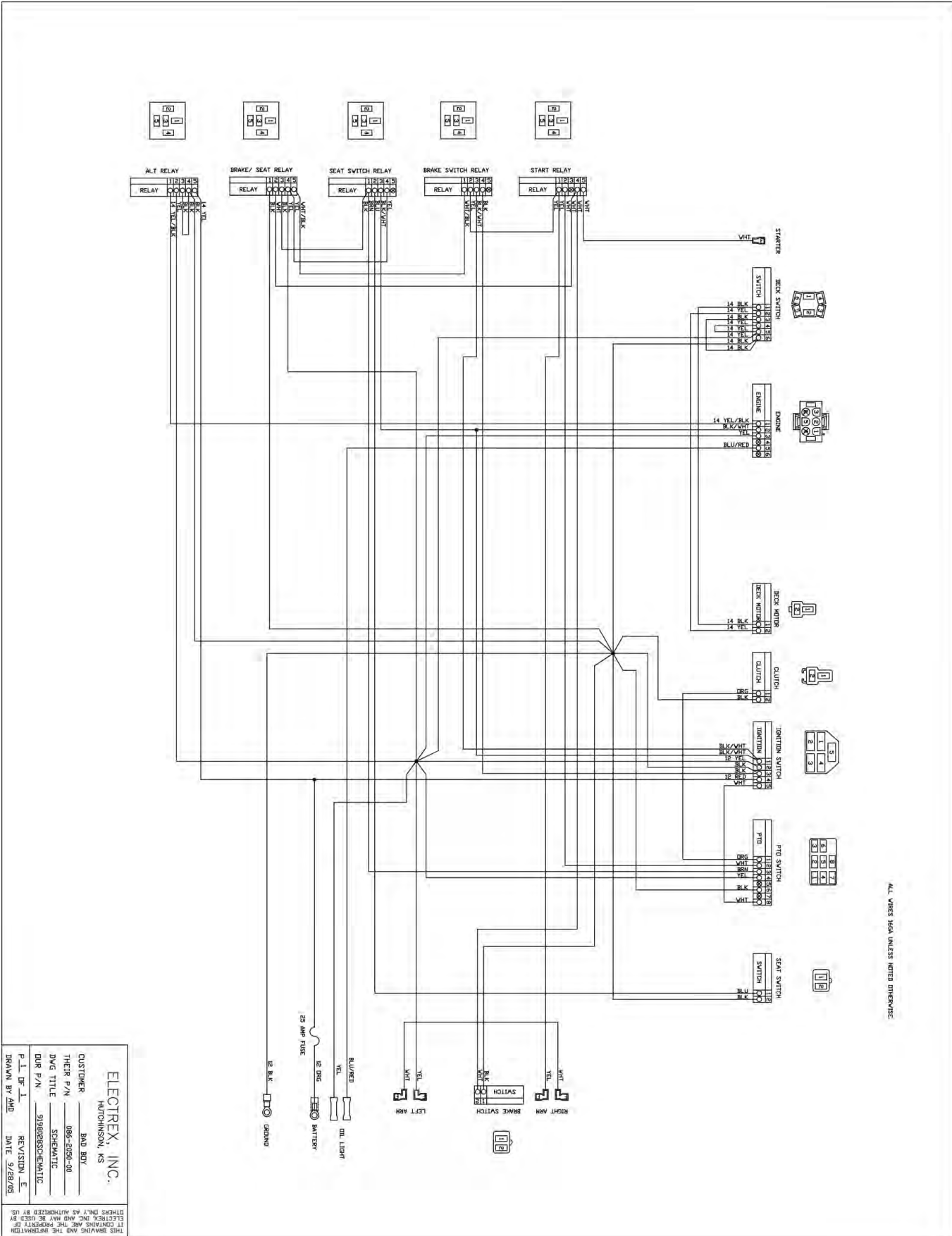

ALL WIRES RED UNLESS NOTED OTHERWISE

**ELECTREX, INC.**  
 HUTCHINSON, KS  
 CUSTOMER: BMB BY  
 THEIR P/N: 086-2050-00  
 DWG TITLE: SCHEMATIC  
 OUR P/N: 918928SCHEMATIC  
 P. 1 OF 1 REVISION: E  
 DRAWN BY: AND DATE: 9/28/05

THIS DRAWING AND THE INFORMATION CONTAINED HEREIN IS THE PROPERTY OF ELECTREX, INC. AND MAY BE USED BY OTHERS ONLY AS AUTHORIZED BY US.

---

## SECTION 5: FRAME

The front fork nuts require a torque of 40ft-lbs. While applying this torque, turn the fork itself to ensure no damage is done to the bearing. This operation is only necessary if a repair requires it.

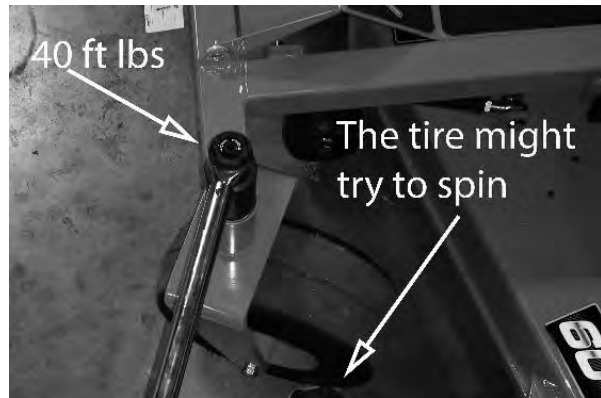

Torque rear wheel lugs to 65-75 ft. lbs. Re-torque at every oil change and check at every mowing.



There are two grease zerks located on each of the two turnbuckles (4 Total). Grease at every oil change.

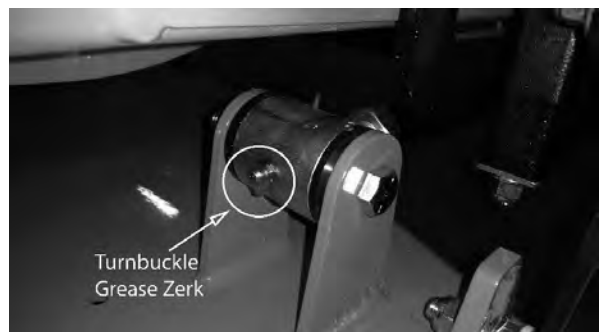

The pump belt tensioner is located under the engine and has a grease fitting at its pivot point. Grease at every engine oil change.

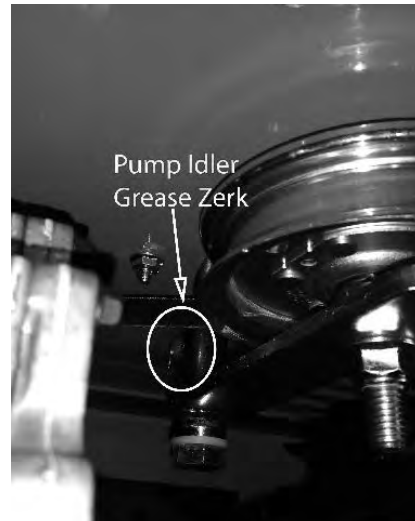

The deck belt tensioner is located at the rear of the deck and has a grease fitting on its pivot point. Grease at every engine oil change.



The control arm blocks have grease fittings located on the top of each block. Grease one time a year.

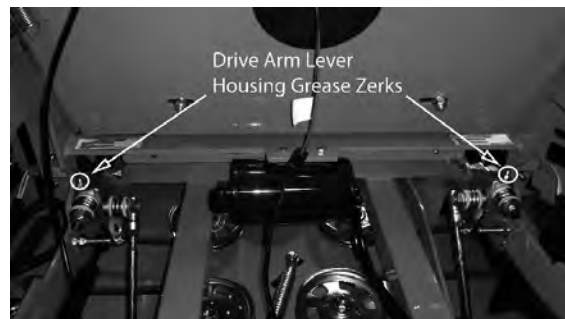



## SECTION 6: CUTTING DECK

### Deck belt removal

- 1) Remove ignition key.
- 2) Raise the deck to its highest position.
- 3) Remove the right pulley cover.
- 4) While lifting up on the belt (as shown in the photograph), rotate the pulley until the belt is free of the pulley. Exercise caution while performing this step as fingers can easily become caught between the belt and pulley.

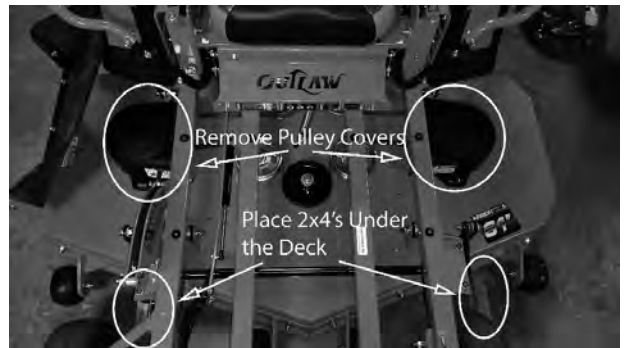

### Deck belt installation:

- 1) Follow steps 1 and 2 from the deck removal section.
- 2) Take off both pulley covers and route the belt by following the belt route sticker.
- 3) The easiest way to finish running the belt is routing the belt through the deck pulleys and carefully slipping the belt onto the clutch in the rear of the engine.
- 4) Verify that the belt is routed properly as improper routing can damage the spindles as well as the engine.

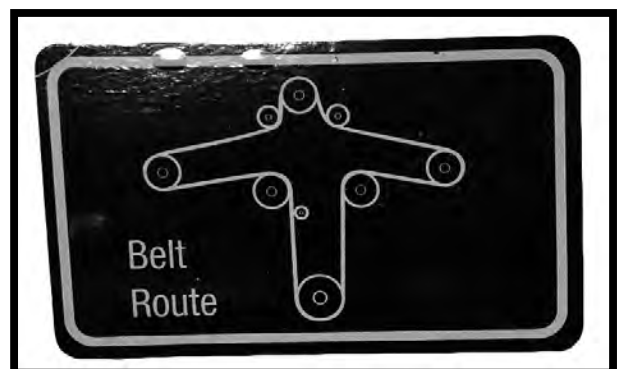
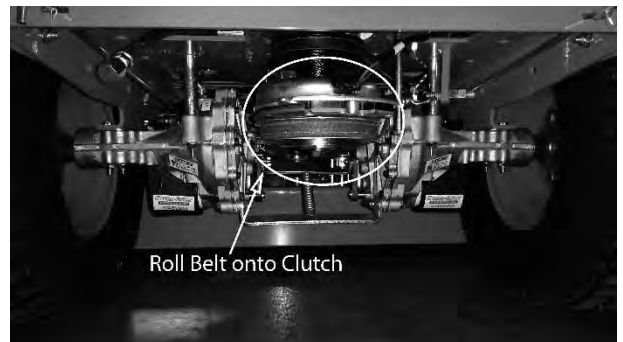

- 1) Start on a flat level surface and set the air pressure in all four tires to 12 psi.
- 2) Get 2 2x4s and make sure that the wider sides are similar length.
- 3) Take off the foot pedal and raise the floor plate.
- 4) Lower the deck onto the 2x4s and pin the deck into its top available height. Remove the dampener that attaches to the actuator bar using two 1/2" wrenches.
- 5) Now ensure that the deck is level left to right and has a pitch down of 1/4" from the back to the front. This can be done by adjusting the tabs on the deck.
- 6) Loosen the bolts on the back of the deck using two 3/4" wrenches until the deck hanger is resting against the bolt.
- 7) Adjust the front deck hanger until there is 1/4" gap between the deck hanger and the bolt that it rests on.
- 8) Reattach the dampener to the actuator bar.
- 9) Place the floorplate down and place the foot pedal back on and you should be ready to mow.

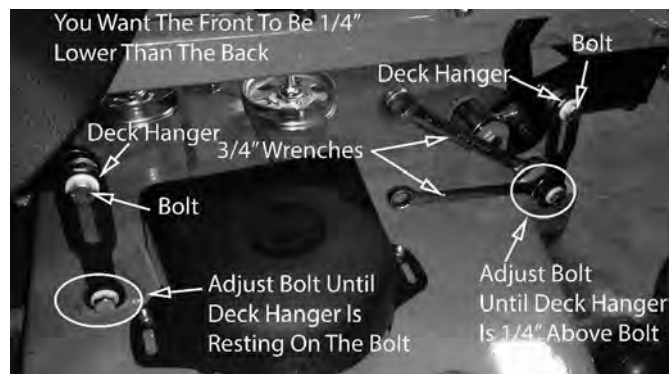
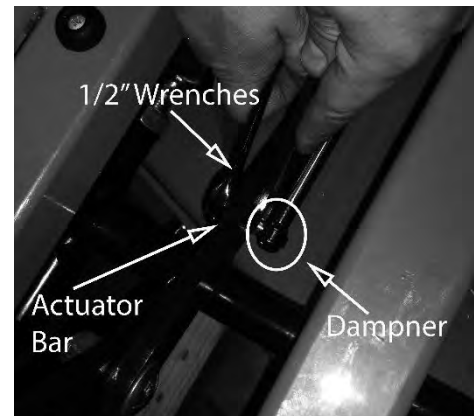
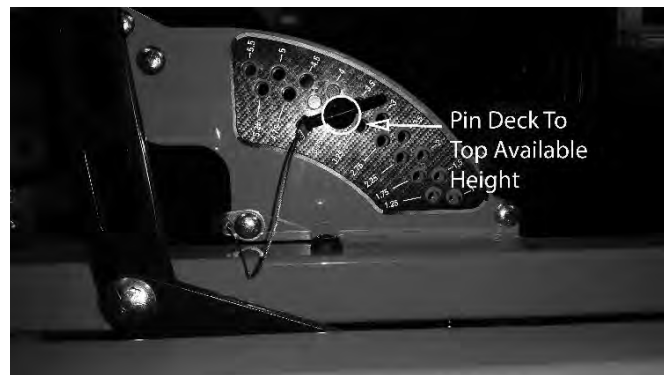
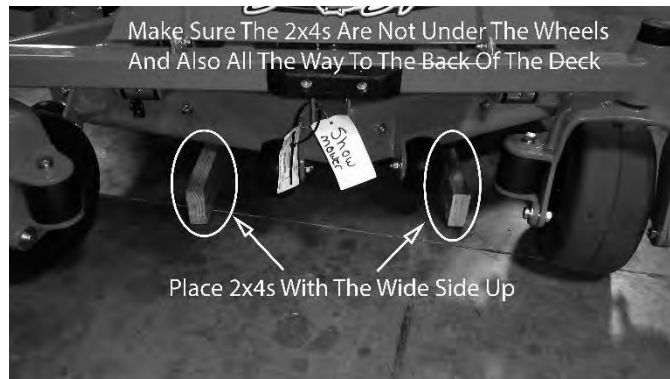

The deck spring tension is critical. If the tension is too high, premature failure of the deck belt and blade spindles can occur. If the tension is too low, the belt can 'jump off' or slip on the pulleys. This results in reduced cut quality and early belt failure.

Spring tension adjustments can be made by sliding the bolt shown above forward or backward in the slot of the deck. Belt tension should be 70-75 lbs. for a 54" deck and 75-80 lbs. for a 61" and 72" deck, with the deck at its lowest setting.

Use a belt tension gauge to ensure the proper tension. Your dealer or service center will have a belt tension gauge or you can buy one (Part Number 041-9999-00).

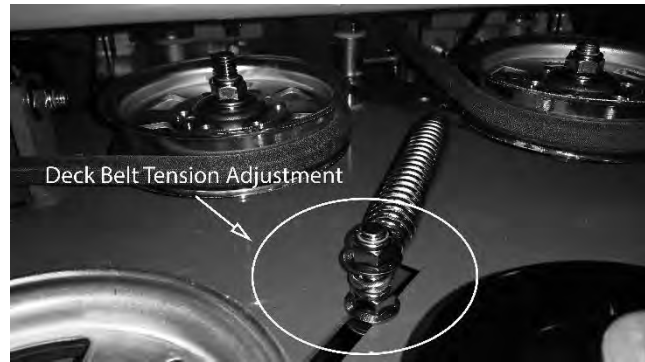

### Blade Sharpening:

The blade on the top (see photo) was utilized long after replacement was required. In addition to a decline in cut quality, failure to replace a worn or damaged blade creates a major safety hazard. Bad Boy recommends that blade sharpening be performed by a professional.



## Blade Removal:

To change blades, it may be easier to use a piece of wood to keep the blade from turning so that the bolt can be loosened. Use a 15/16" socket and impact Drill, or a wrench and an extension to gain more leverage. You might need to put a 3/4" wrench on top of the pulley bolt to keep the blade from spinning. **Bolts used have right-handed threads.**

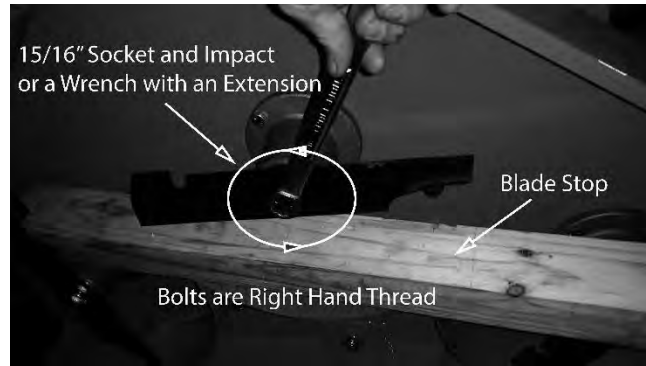

Re-torque the blade bolts to 90-110 lbs.

The blade spindles contain a sealed ball bearing inside the top and bottom of the spindle. The bearings are replaceable for a more cost effective repair.



# PARTS SECTION



## Outlaw & Outlaw Extreme Front Wheel Assembly

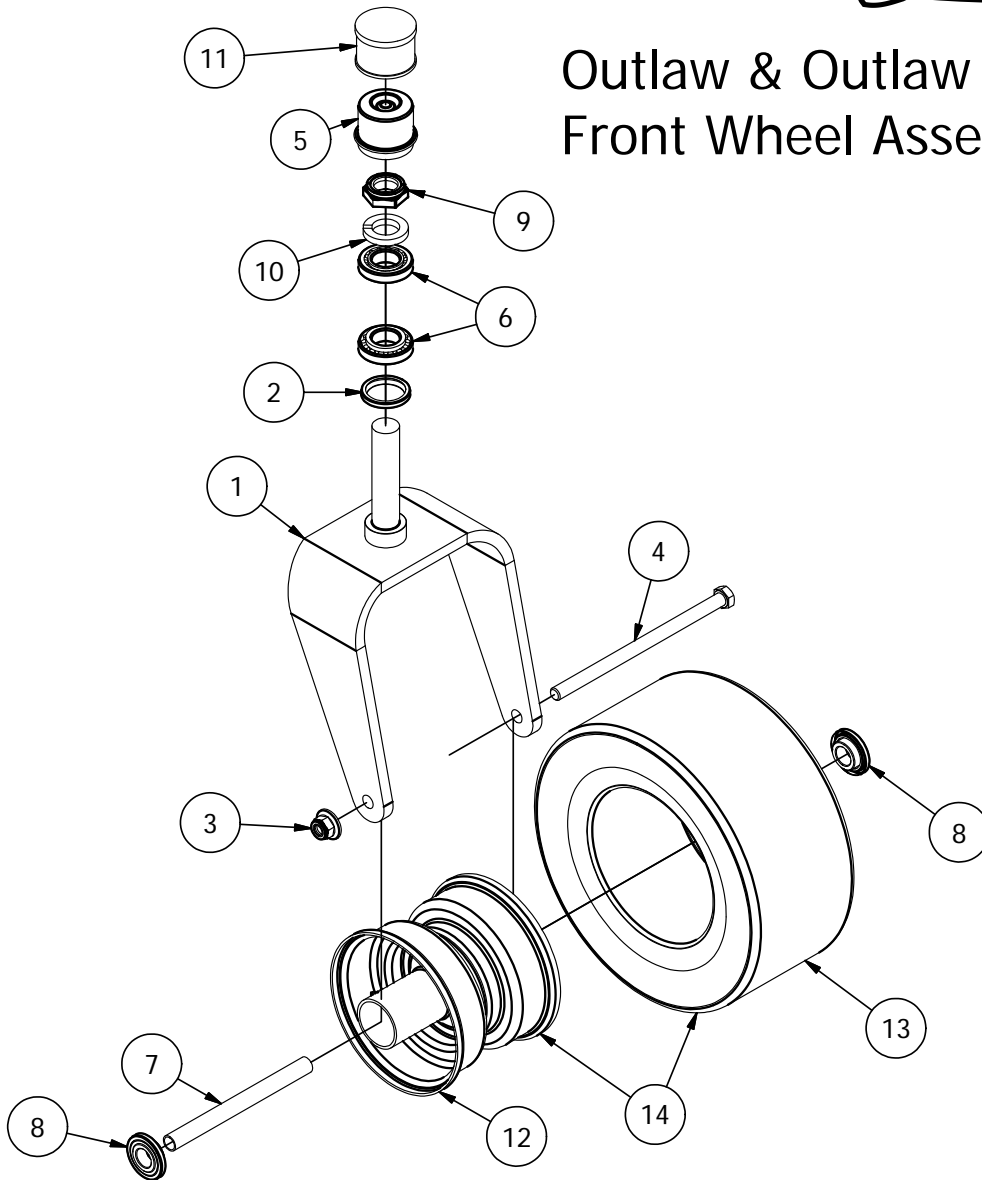

Parts List			
ITEM	QTY	PART NUMBER	DESCRIPTION
1	1	023-7913-00	Front Fork
2	1	012-7003-00	Seal
3	1	013-8050-00	1/2-13 Nylon Flange Nut
4	1	018-7010-00	1/2" x 9" GR 5 Hex Bolt
5	1	014-7005-00	Dust Cover
6	2	010-7001-00	Bearing
7	1	025-5202-00	Front Wheel Spanner
8	2	022-7009-00	1 3/8" Wheel Bearing
9	1	013-9004-00	1" Fine Thread 1/2 Nylock Nut
10	1	019-3000-00	1" Lock Washer
11	1	014-8047-00	Spring Cap Cover
12	1	022-3090-00	Black Front Tire Rim
13	1	022-5347-00	13 x 6.50 - 6 Tire
14	1	022-3085-00	13x6.5-6 Large Bore - Black Front Assembly

# Outlaw Drive Arms

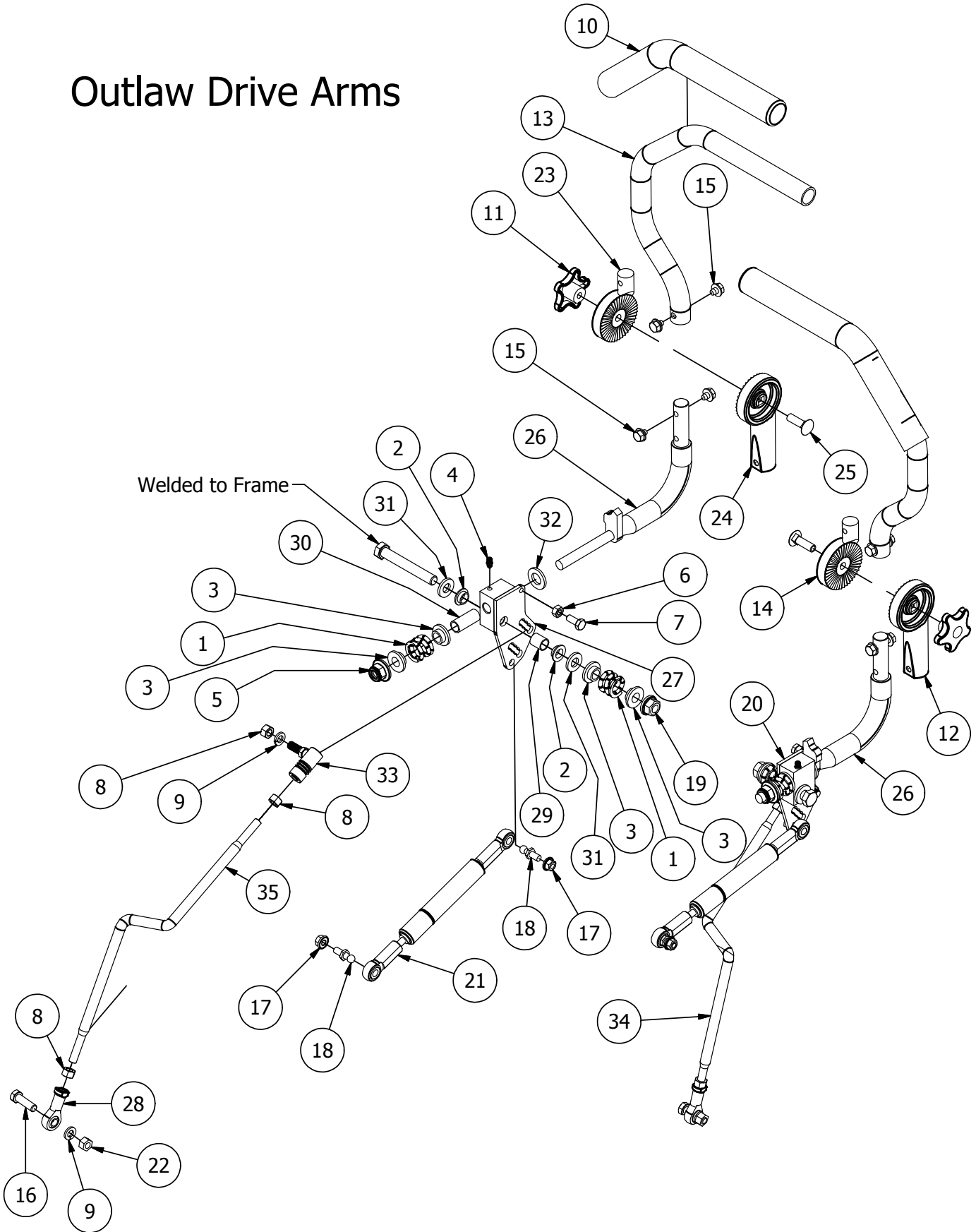



Parts List			
ITEM	QTY	PART NUMBER	DESCRIPTION
1	4	034-8025-00	Drive Lever Spring
2	4	032-5055-00	Bushing for 2012 Drive Arms
3	8	019-8027-00	.515 ID Nylon Shoulder Washer
4	2	024-6034-00	1/4" Press in Grease Fitting
5	2	013-8050-00	1/2-13 Nylon Flange Nut
6	2	013-8043-00	5/16" Nut
7	2	018-8063-00	5/16" x 3/4" Hex Bolt
8	6	013-6051-00	3/8" Fine Threaded Jam Nut
9	4	019-5037-00	3/8" Lock Washer
10	2	069-4010-00	Black Steering Grip
11	2	045-5000-00	Black Knob for Adjustable Steering Arm
12	1	031-9015-70	Lower Adjuster - Steering Arm- Right
13	2	031-9010-00	Upper Tube-Adjustable Steering
14	1	031-9016-70	Upper Adjust Steering Arm- Right
15	8	018-2020-00	5/16-18 1/2 HWH Bolt-Steering
16	2	018-5040-00	3/8" x 1 1/4" Hex Bolt
17	4	013-9002-00	5/16" Flange Nut
18	4	018-2050-00	10mm Damper Ball Stud-Steering
19	2	013-0010-00	1/2-13 Mechanical Lock Nut Grade F
20	1	027-8901-00	2013 Drive Lever Housing (Right)
21	2	087-3000-00	Steering Damper
22	2	013-6014-00	3/8-16 Hex Nuts Zinc
23	1	031-9017-70	Upper adjuster-Steering Arm- Left
24	1	031-9014-70	Lower Adjuster - Steering Arm- Left
25	2	018-5043-00	3/8" x 1 1/4" Carriage Bolt
26	2	031-9025-70	Steering Arm Elbow - Right
27	1	027-8900-00	2013 Drive Lever Housing (Left)
28	2	048-3000-00	Spherical Rod End - Outlaw
29	2	032-1010-00	Drive Arm Block Insert-short
30	2	032-1020-00	Drive Arm Block Insert-long
31	4	019-7000-00	.505x1x .125 Oil Impregnated washer
32	2	019-6017-00	.630 ID Plastic Washer
33	2	099-2009-00	Quick Release Ball Joint
34	1	035-0075-00	2015 Outlaw Push Rod - Right
35	1	035-0050-00	2015 Outlaw Push Rod - Left

# Outlaw Gas Tank Assemblies

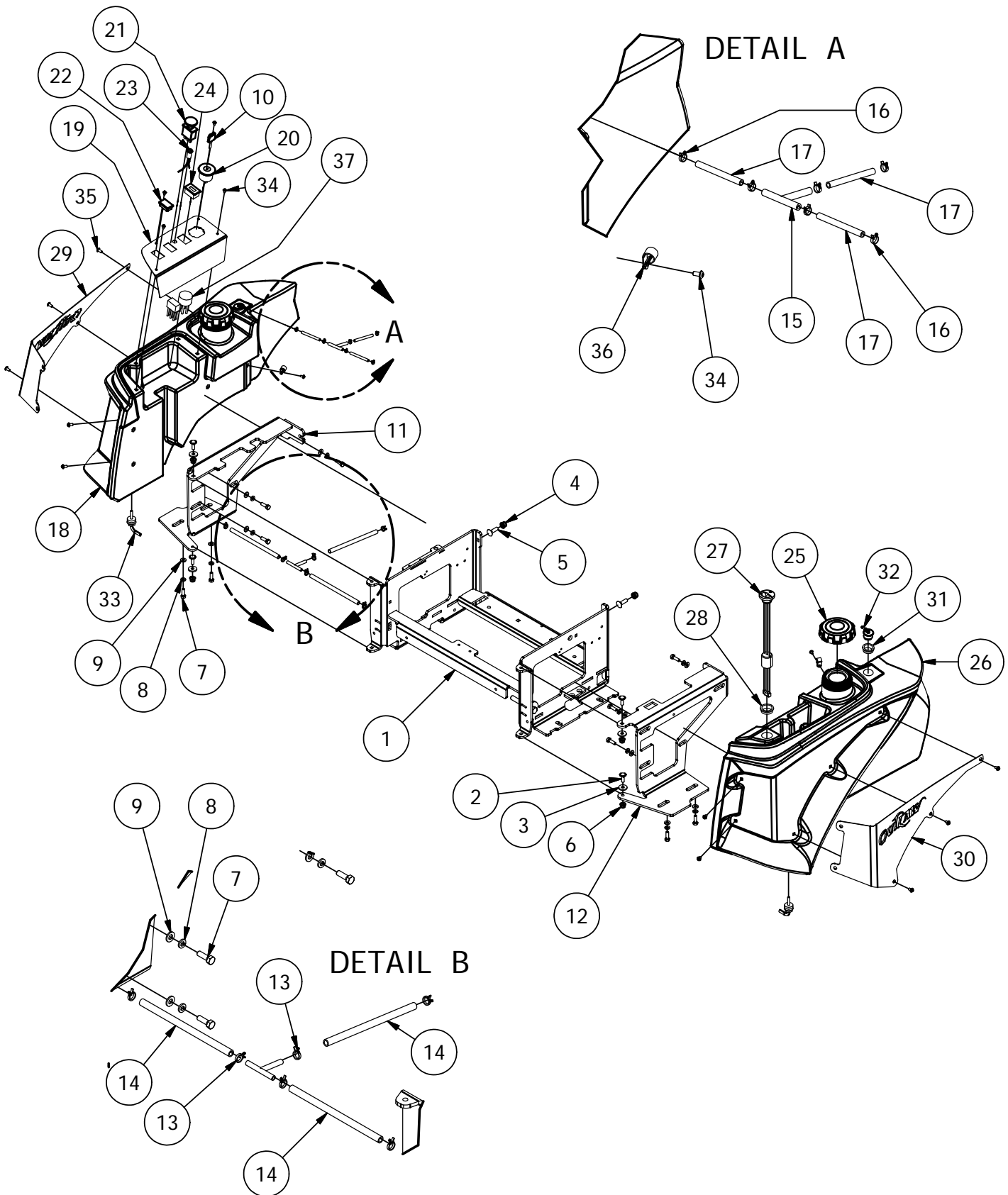





Parts List			
ITEM	QTY	PART NUMBER	DESCRIPTION
1	1	080-5116-00	2016 Outlaw Seat Bracket
2	4	018-8065-00	5/16-18 x 1 Carriage Bolts Zinc
3	4	019-6042-00	.360 ID Plastic Washer
4	2	013-5202-00	3/8" Nylock Flange Nut
5	2	018-5043-00	3/8" x 1 1/4" Carriage Bolt
6	4	013-8049-00	5/16-18 Nylon Insert Flange Nut Zinc Orange Nylon
7	10	018-2007-00	5/16" x 1" Bolt
8	10	019-8051-00	5/16" Lock Washer
9	10	019-8044-00	5/16" Flat Washer
10	1	042-9000-00	Ignition Key
11	1	031-2040-00	Outlaw 2015 Tank Support (Right)
12	1	031-2045-00	Outlaw 2016 Tank Support (Left)
13	6	072-8069-00	1/4 Fuel Hose Clamp
14	3	051-8067-00	1/4" Fuel Line Hose
15	2	073-8068-00	fuel line T
16	6	072-8070-00	3/16 Vinyl Clamp
17	3	051-8072-00	1/4" Vinyl Tubing
18	1	067-1180-50	Outlaw 2015 Fuel Tank (Right)
19	1	079-3360-00	Analog Control Panel Outlaw
20	1	077-8076-00	Ignition Switch
21	1	056-8058-00	PTO Switch
22	1	018-1040-00	Light Plug
23	1	089-1000-00	Oil Light
24	1	083-4013-00	Tachometer
25	2	066-8076-00	Fuel Cap (Kelch)
26	1	067-1190-50	Outlaw 2015 Fuel Tank (Left)
27	1	067-4080-00	Fuel Gauge w/Grommet
28	1	067-6054-00	Grommet for Fuel Gauge
29	1	079-3280-00	Outlaw Tank Panel (Right)
30	1	079-3281-00	Outlaw Tank Panel (Left)
31	2	067-6053-00	ROV Grommet
32	2	067-6060-00	Rollover Valve - Black
33	2	067-6055-00	Fuel Tank Hose Nipple w/Filter
34	6	018-2010-00	10-32 x 3/8" Button Socket Head Bolt
35	10	018-2012-00	1/4" x 1/2" BS C/S 18-8 SS
36	2	072-0001-00	3/8 Cable Clamp-Black Nylon
37	1	086-2050-00	Wiring Harness

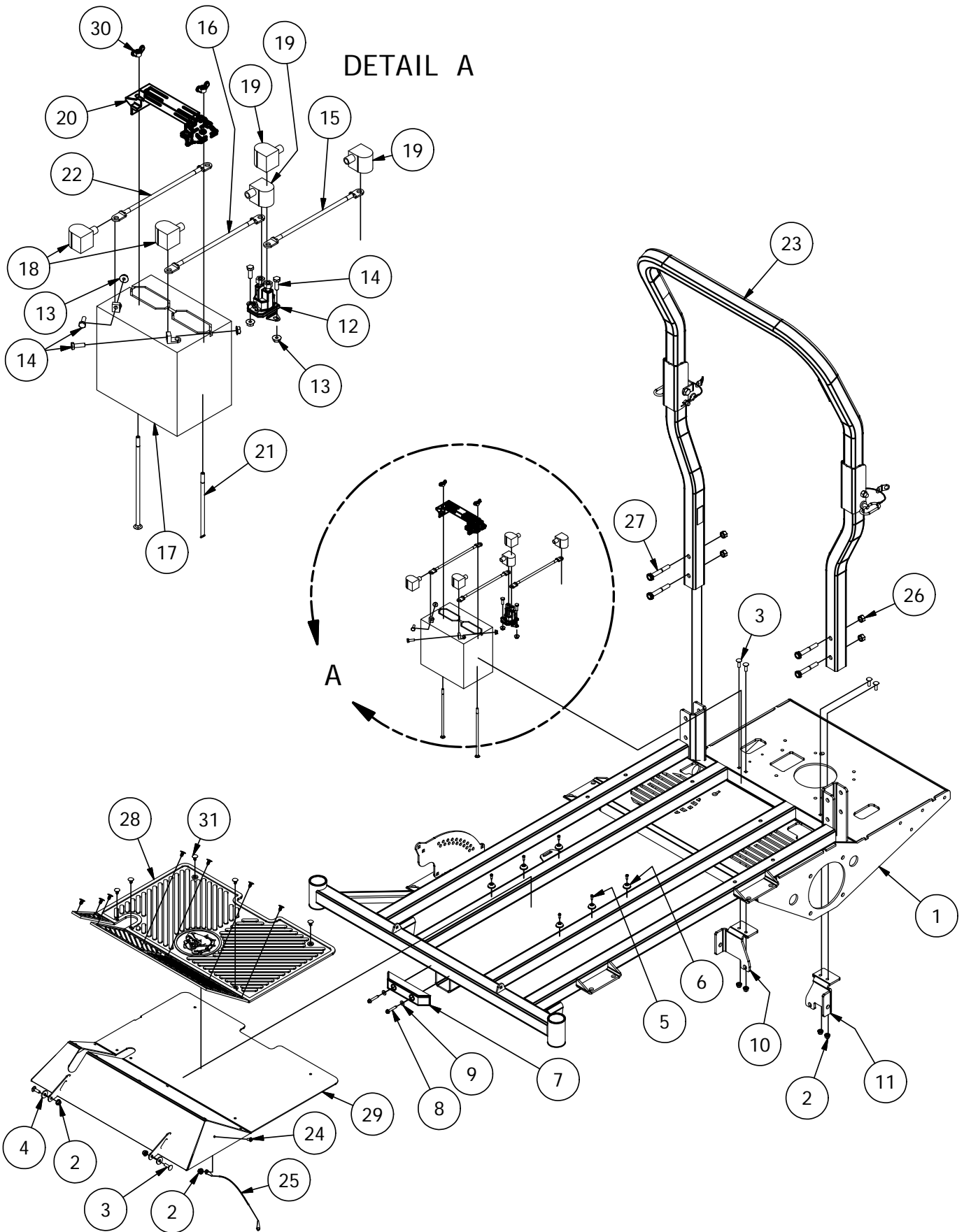



Parts List			
ITEM	QTY	PART NUMBER	DESCRIPTION
1	1	070-5370-00	2015 Standard/Extreme Outlaw Frame
2	7	013-8049-00	5/16" Nylock Flange Nut Zinc
3	6	018-8065-00	5/16" x 1" Carriage Bolt
4	2	019-6042-00	.360 ID Plastic Washer
5	6	030-3050-00	#10 x 1/2" Self Tapping Screw
6	6	029-4010-00	Button Bumper
7	1	029-7038-00	8" Rubber Bumper
8	2	030-7039-00	1/4" x 1 1/2" Self Tapping Screw
9	2	019-7040-00	1/4" Flat Washer
10	1	039-2113-00	Outlaw Brake Cable Mount Bracket (Right)
11	1	039-2110-00	Outlaw Brake Cable Mounting Bracket (left)
12	1	108-5349-00	Solenoid
13	4	013-9001-00	1/4-20 Hex Flange Nuts Zinc w/Serrations
14	4	018-8052-00	1/4-20 x 3/4 GR 5 Hex Bolts Zinc
15	1	086-0003-00	Red Battery Cable Alternator to Starter Cable
16	1	064-5301-00	12 in red battery cable
17	1	068-8049-00	Battery
18	2	103-5400-00	Black Boot For Ground Cable
19	3	103-5300-00	Red Boot
20	1	043-8929-00	Battery Hold Down
21	2	018-8050-00	1/4-20 X 8 Carriage Bolt
22	1	086-0005-00	Ground Cable
23	1	089-0002-00	2015 Outlaw 2x2 Folding ROPS
24	1	018-8064-00	1/4" x 5/8" BS C/S 18-8 SS
25	1	064-2006-00	Floor board Cable W/ Swivel Ends
26	4	013-0005-00	1/2" Center Lock Nut
27	4	018-0050-00	1/2-13 X 3.25 Hex Bolt - Grade 5
28	1	081-2050-00	2016 Outlaw Floor Mat
29	1	079-3130-00	2016 Outlaw Floor Panel
30	2	013-8051-00	1/4" Wing Nut
31	12	040-6090-00	5/8" Christmas Tree Fastener

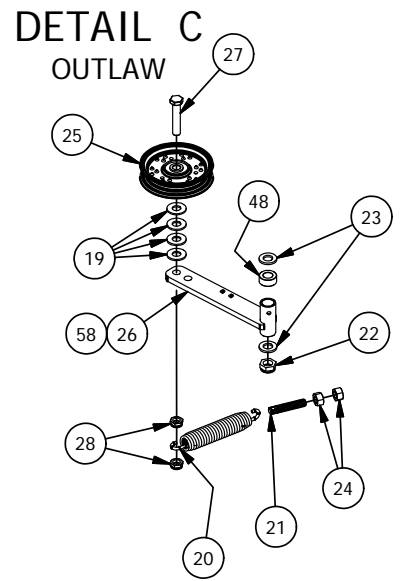
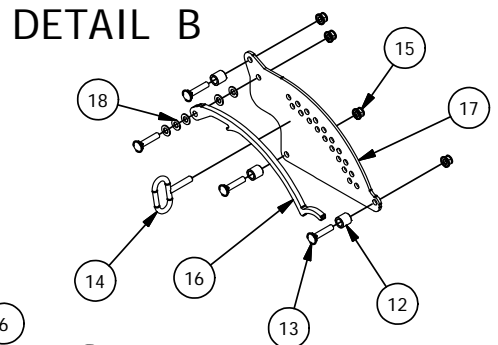
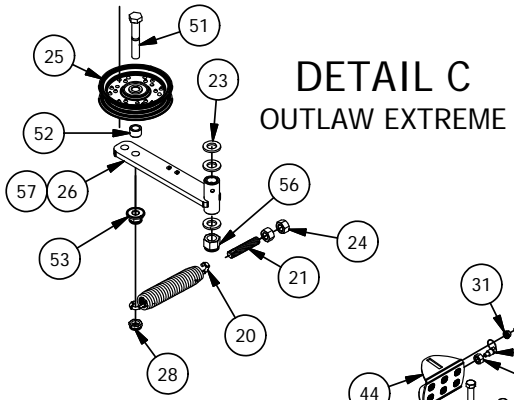

### DETAIL A

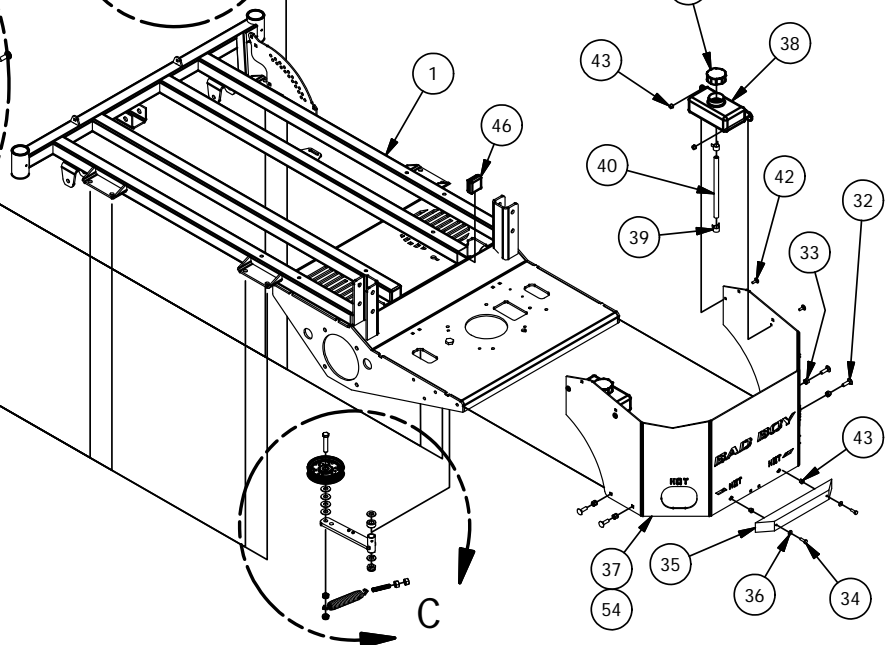
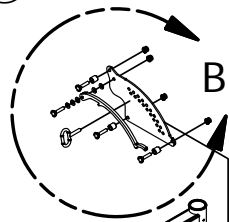
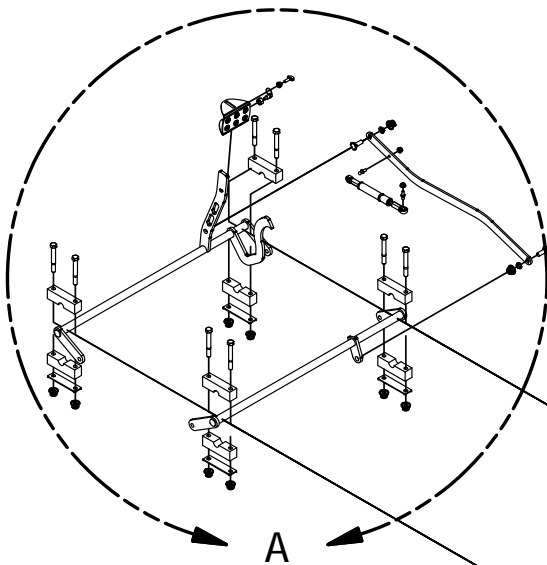



Parts List			
ITEM	QTY	PART NUMBER	DESCRIPTION
1	1	070-5370-00	2015 Standard/Extreme Outlaw Frame
2	1	028-6030-00	2015 Outlaw Act Bar Assembly (Front)
3	1	028-6040-00	2015 Outlaw Act Bar Assembly (Rear)
4	1	028-6050-00	Outlaw Deck Linkage Rod
5	10	013-8050-00	1/2-13 Nylon Flange Nut
6	2	032-3000-00	Bushing- SF-1620-4
7	2	018-0008-00	1/2 x 1-1/2 Carriage Bolt
8	4	017-9000-00	Two Piece Pillow Block (Male)
9	4	017-9050-00	Two Piece Pillow Block (Female)
10	4	017-9025-00	Two Piece Pillow Block Strap
11	8	018-5019-00	1/2" x 4" Bolt (Grade 8)
12	3	025-5203-00	Spacer 3/4 OD x 1/2 ID x 3\4 Length
13	4	018-0009-00	3/8 x 1 3/4 Carriage Bolt
14	1	040-4000-00	Deck height lever pin
15	4	013-5202-00	3/8" Nylock Flange Nut
16	1	031-0100-00	Outlaw Deck Lever Lock
17	1	026-2100-00	Outlaw Height Indicator Plate (Outer)
18	5	019-2003-00	.390 x .750 x .062 Nylon Washer
19	4	019-5010-00	1/2" Brass Washer (Base Only)
20	1	034-2009-00	2009 Deck/Pump Idler Spring
21	1	018-2004-00	All Thread-Pump Idler Tensioner
22	1	013-5301-00	5/8" Nylock (1/2 Jam) (Base Only)
23	2 (3-Extreme)	019-6017-00	.630 ID Plastic Washer
24	3	013-7018-00	1/2" Hex Nut
25	1	033-6001-00	4 3/4 Idler Pulley - ABFI-76
26	1	039-6945-00	Deck Idler
27	1	018-0015-00	1/2" x 3" Hex Bolt (Base Only)
28	2 (1-Extreme)	018-4010-00	1/2" Nylock Nut (1/2 Jam)
29	1	087-5400-00	200 lb Gas Spring- 54" Deck outlaw
30	2	018-2050-00	10mm Damper Ball Stud-Steering
31	3	013-9002-00	5/16" Flange Nut
32	4	018-5043-00	3/8" x 1 1/4" Carriage Bolt
33	4	013-5041-00	3/8 Nylock Nut
34	2	018-4702-00	1/4-20 x 1-1/4 GR 5 Hex Bolt
35	1	029-7037-00	14" Rubber Bumper
36	2	019-7040-00	1/4" Flat Washer
37	1	026-2180-00	2015 Outlaw Rear Plate
38	2	067-8085-00	Expansion Tank Outlaw
39	4	072-8074-00	5/8 Wire Clamp-Outlaw Only
40	2	051-9000-00	5/8 Braided Hose
41	2	066-5050-00	Hydraulic Tank Cap
42	4	019-8040-00	1/4" x 3/4" Carriage Bolt
43	6	013-2050-00	1/4-20 Nylon Insert flange Nut
44	1	026-0013-00	Outlaw Deck Lift Pedal
45	1	040-5000-00	Pull Pin
46	2	014-9000-00	2X2 Frame Plug
47	1	030-0010-00	5/16-18 x1 Thumb Screw Zinc
48	1	025-7020-00	5/8" x 1/" Collar W/One Set Screw
49	1	087-6100-00	250 lb Gas Spring - 61" Deck Outlaw
50	1	087-7200-00	300 lb Gas Spring - 72" Deck Outlaw
51	1	018-6036-00	1/2 x 2-1/2 Hex Bolt (Extreme Only)
52	1	025-7036-00	1/2" x 1/2 Spacer (Extreme Only)
53	1	013-8050-00	1/2"-13 Nylon Flange Nut (Extreme Only)
54	1	026-2190-00	2016 Outlaw/XP Rear Cover (36 Vanguard Only)
55	2	018-2049-00	13mm Damper Ball Stud for 72" Deck only
56	1	013-7021-00	5/8 Std NC Nylock Nut (Extreme Only)
57	1	039-6945-03	Pump Idler Assy - Outlaw Extreme Components:25,26,28,51,52,53
58	1	039-6945-04	Pump Idler Assy - Base Outlaw Components:19,25,26,27,28

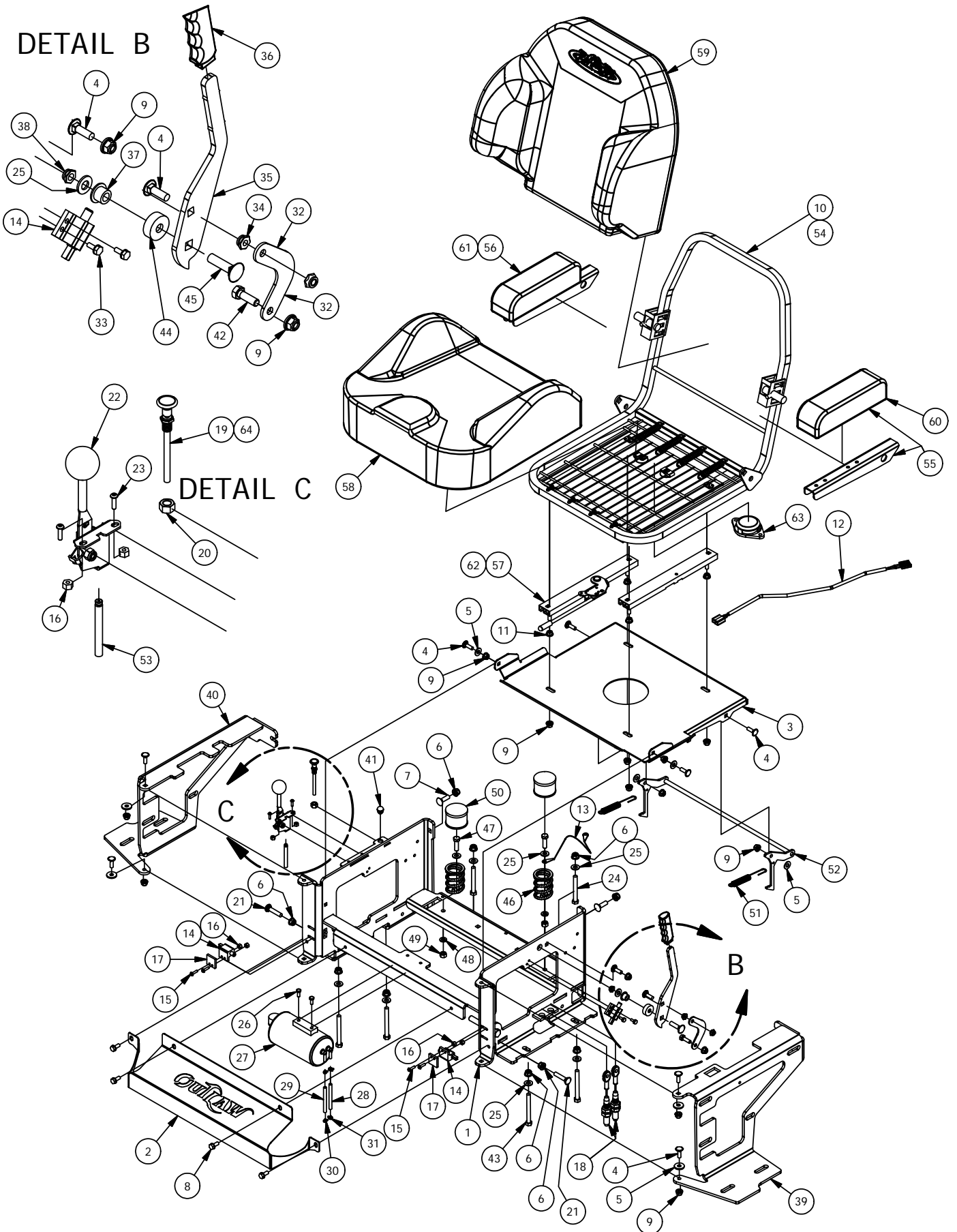



Parts List			
ITEM	QTY	PART NUMBER	DESCRIPTION
1	1	080-5116-00	2016 Outlaw Seat Bracket
2	1	014-2100-00	Outlaw Cooler Cover
3	1	026-2016-00	2016 Seat Plate Outlaw
4	10	018-8065-00	5/16-18 x 1 Carriage Bolts Zinc
5	8	019-6042-00	.360 ID Plastic Washer
6	10	013-5202-00	3/8" Nylock Flange Nut
7	2	018-5043-00	3/8" x 1 1/4" Carriage Bolt
8	4	030-7042-00	5/16 x 3/4 washer head type F screw
9	14	013-8049-00	5/16" Nylock Flange Nut Zinc
10	1	071-5060-00	2015 Outlaw Seat (Extreme Outlaw Only)
11	4	013-9002-00	5/16" Flange Nut
12	1	036-5300-00	Seat Switch Adapter
13	1	064-8081-00	Seat Cable
14	3	077-8073-00	Safety Switch
15	4	018-8058-00	10-24 x 1 BS C/S 18-8 SS
16	6	013-5019-00	10-24 Nylon Insert Locknut
17	2	025-6041-00	Switch Block Plastic
18	2	064-8056-00	Long Brake Cable
19	1	054-8017-00	Choke
20	1	013-6051-00	3/8" Fine Threaded Jam Nut
21	2	018-0009-00	3/8 x 1 3/4 Carriage Bolt
22	1	055-2012-00	Universal Throttle Head - 2012
23	2	018-5200-00	10-24 X 5/8 BS Button Head Bolt
24	2	018-4700-00	3/8-16x3 grade 5 hex bolt
25	9	019-5029-00	3/8" Flat Washer
26	2	018-0024-00	M6-1.0 X 16MM Hex Bolt
27	1	067-0020-00	Carbon Canister
28	1	051-8072-00	1/4" Vinyl Tubing
29	1	051-8073-00	3/16 Vinyl Tubing
30	2	072-8073-00	3/16" Vinyl Hose Clamp
31	2	072-8070-00	3/16 Vinyl Clamp
32	1	039-0150-00	Brake Cable Adapter Bracket
33	2	018-1080-00	12-24x 1/2 HWH Bolt
34	2	013-9005-00	5/16-18 Nylock Jam Nut 1/2 Nut
35	1	069-1000-00	Brake Handle Cam Over
36	1	069-7000-00	Rubber Brake Grip-cZT/ZT 2013
37	1	032-5053-00	Bronze Bushing SF-1220-8
38	1	013-0009-00	3/8-16 Hex Flange Top L/N
39	1	031-2045-00	Outlaw 2016 Tank Support (Left)
40	1	031-2040-00	Outlaw 2015 Tank Support (Right)
41	1	014-2000-00	Black Plug - 5/8" Head (EFI Engines Only)
42	1	018-2007-00	5/16" x 1" Bolt
43	4	018-1010-00	3/8-16x3-1/2 grade 5 hex bolt
44	1	025-0001-00	2015 Brake Lever Spacer
45	1	018-4706-00	3/8 x 1 1/2 Carriage Bolt
46	2	034-8045-00	Seat Spring
47	2	018-5040-00	3/8" x 1 1/4" Hex Bolt
48	2	019-5037-00	3/8" Lock Washer
49	2	013-6014-00	3/8" Hex Nut
50	2	014-8047-00	Spring Cap Cover
51	2	034-1025-00	Brake Spring
52	1	028-0085-00	Seat Latch Rod Assembly 2016 Models
53	1	055-8021-75	Outlaw Throttle Cable (Cable Only)
54	1	071-5055-00	2016 Outlaw/Compact Outlaw Seat (Base Outlaw Only)
55	1	071-5056-00	Base Outlaw Seat Arm Left
56	1	071-5057-00	Base Outlaw Seat Arm Right
57	1	071-2020-00	Base Outlaw Seat Rails (Pair)
58	1	071-5063-00	Extreme/XP Outlaw Seat Cushion - Bottom
59	1	071-5064-00	Extreme/XP Outlaw Seat Cushion - Back
60	1	071-5062-00	Extreme/XP Outlaw Seat Arm Pads Only (Pair)
61	1	071-5061-00	Extreme/XP Outlaw Seat Arm Rest (Pair)
62	1	071-5015-00	Extreme/XP Outlaw Seat Rails (Pair)
63	1	071-8061-00	Seat Switch
64	1	054-8016-00	FX850 & FX730 Kawasaki Choke Cable

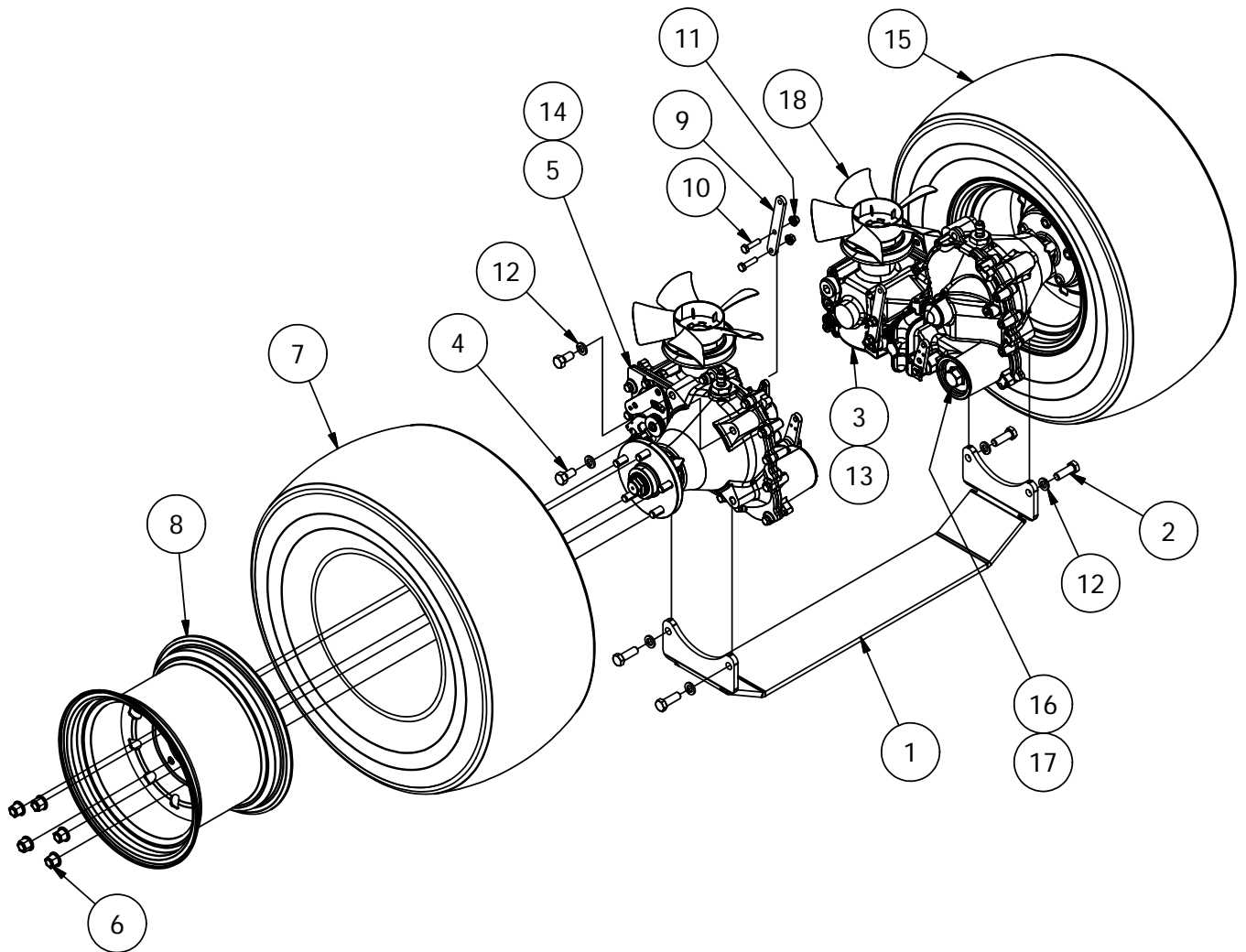

Parts List			
ITEM	QTY	PART NUMBER	DESCRIPTION
1	1	203-0100-00	Outlaw Transaxle Cross Brace
2	4	018-5006-00	1/2" x 1 1/2" Hex Bolt
3	1	050-7000-00	ZT - 5400 - Left (Extreme Only)
4	4	018-2030-00	1/2" x 1" Hex Bolt
5	1	050-7001-00	ZT - 5400 - Right (Extreme Only)
6	10	013-3000-00	Acorn Lug Nut
7	2	022-5349-00	24 x 12 - 12 Tire Pro Maxxis
8	2	022-4070-00	12x12" Black Wheel For 2015 Outlaw
9	2	039-2135-00	2015 Outlaw Brake Adapter (4400 Transaxles Only)
10	4	018-2006-00	5/16 x 1 1/4 Hex Bolt (4400 Transaxles Only)
11	4	013-8049-00	5/16" Flange Nut Zinc W/Serrations (4400 Transaxles Only)
12	8	019-5007-00	1/2" Lock Washer
13	1	050-1000-00	4400 Transaxle - Left (Base Outlaw)
14	1	050-1050-00	4400 Transaxle - Right (Base Outlaw)
15	2	022-4050-00	24 x 12 - 12 Tire and Black Wheel Assembly
16	2	063-1060-00	Hydro Filter for Outlaw Extreme
17	2	063-1070-00	4400 Hydro Filter for Outlaw
18	2	050-2073-00	Fan/Pulley Kit for Outlaw





# Kawasaki FX-730V

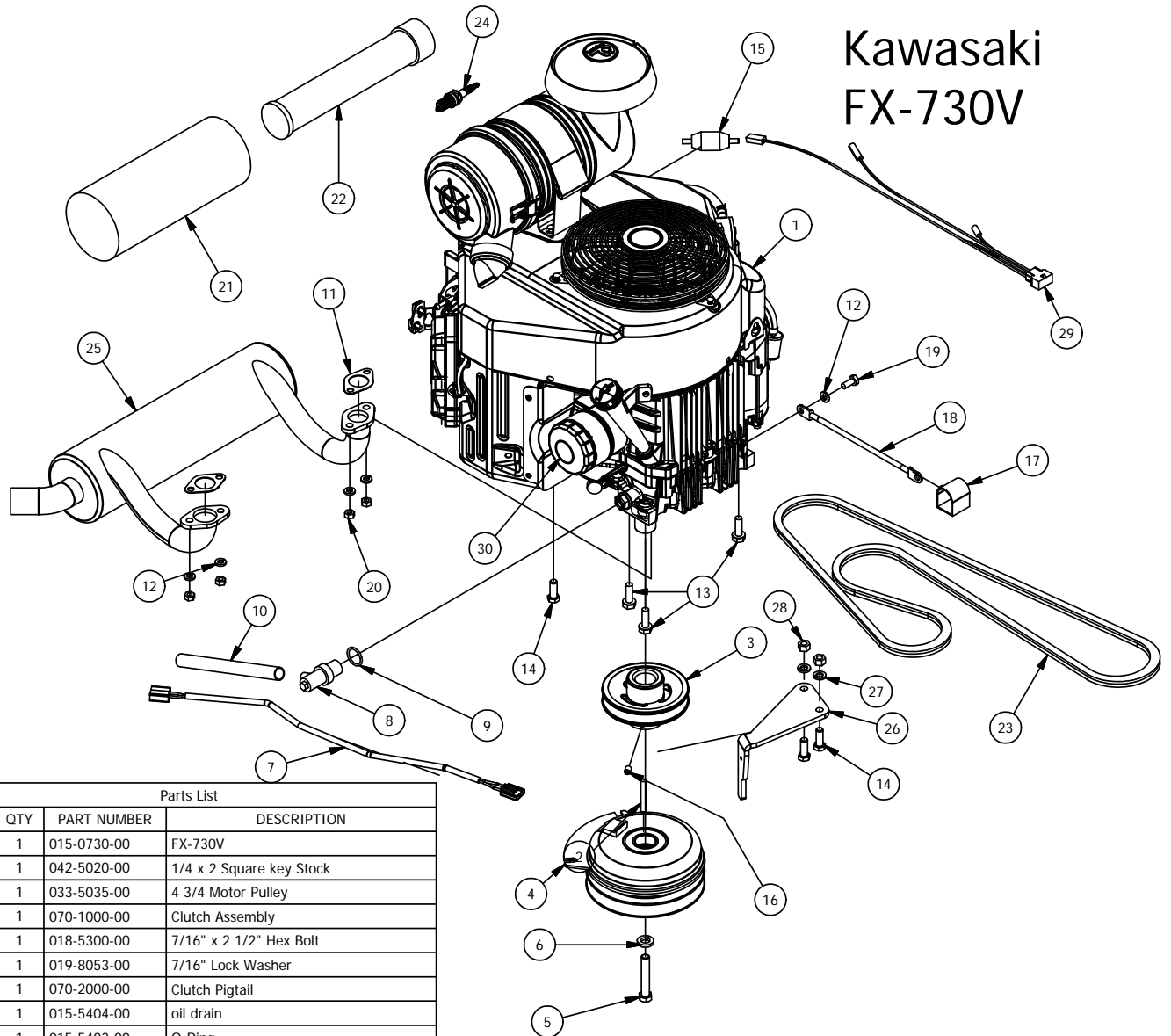

Parts List			
ITEM	QTY	PART NUMBER	DESCRIPTION
1	1	015-0730-00	FX-730V
2	1	042-5020-00	1/4 x 2 Square key Stock
3	1	033-5035-00	4 3/4 Motor Pulley
4	1	070-1000-00	Clutch Assembly
5	1	018-5300-00	7/16" x 2 1/2" Hex Bolt
6	1	019-8053-00	7/16" Lock Washer
7	1	070-2000-00	Clutch Pigtail
8	1	015-5404-00	oil drain
9	1	015-5403-00	O-Ring
10	1	051-8064-00	1/2 Clear Braded Hose Priced/Foot
11	2	015-2709-00	Exhaust Gasket
12	5	019-8051-00	5/16" Lock Washer
13	3	018-1075-00	3/8 x 1 1/8 bolt
14	3	018-6049-00	3/8" x 1" Hex Bolt
15	1	063-6000-00	Universal Inline Fuel Filter
16	1	030-0050-00	5/16 Set Screw
17	1	103-5400-00	Black Boot For Ground Cable
18	1	064-0030-00	Ground Cable
19	1	018-5321-00	M8x1.20x20MM Hex head bolt
20	4	013-0075-00	M8-1.25 Zinc Nut
21	1	063-8019-00	Canister Air Filter- Outer
22	1	063-8020-00	Canister Air Filter- Inner
23	1	041-5048-00	Pump Belt
24	2	015-8001-00	Spark Plug - Kawasaki
25	1	015-0048-00	Exhaust Kawasaki
26	1	057-5906-00	PTO Engager Holder
27	2	019-5037-00	3/8" Lock Washer
28	2	013-6014-00	3/8-16 Hex Nuts Zinc
29	1	086-9002-00	Harness Adaptor
30	1	063-8017-00	Kawasaki Oil Filter

# Kohler 747cc Assembly

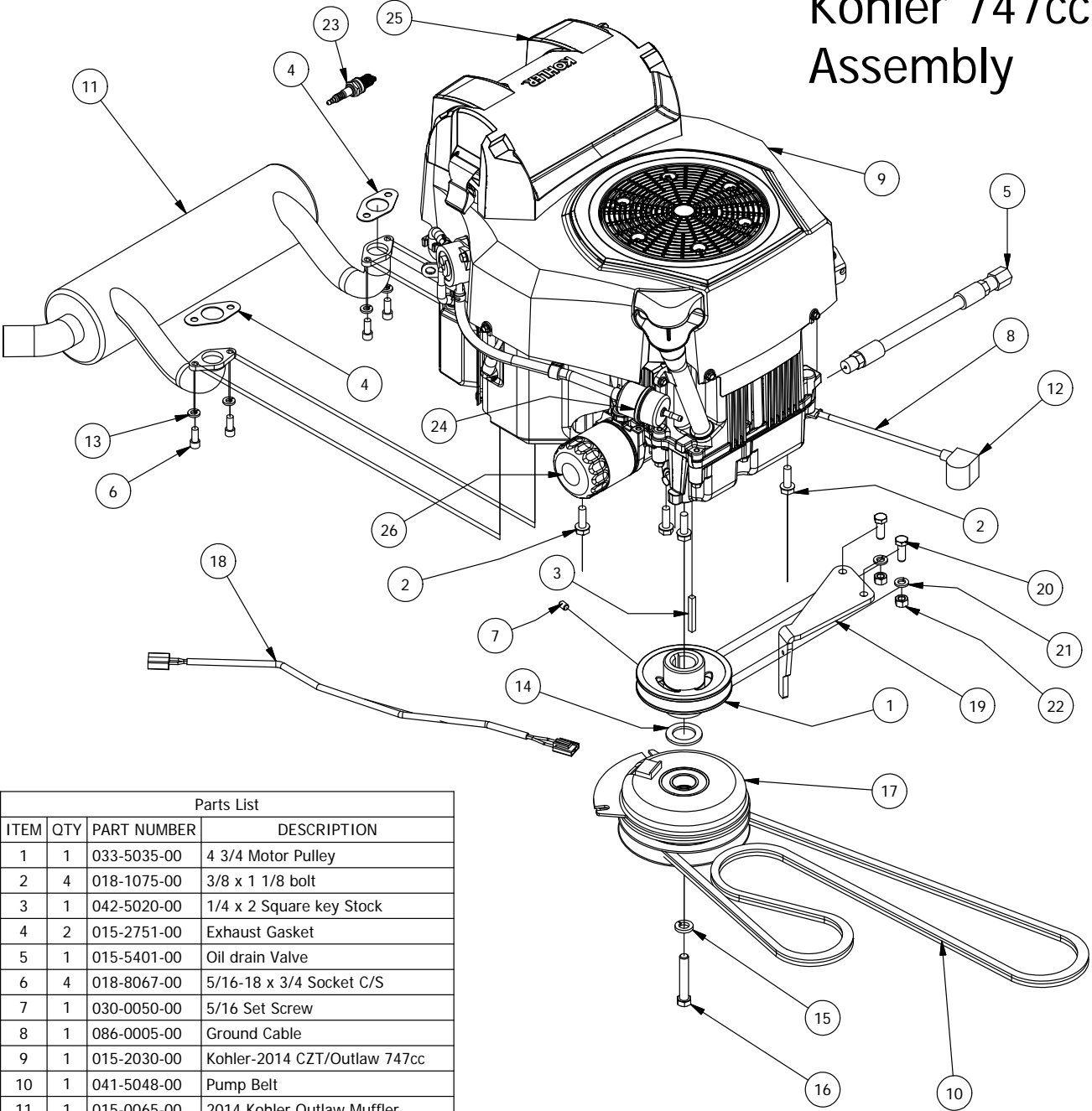

Parts List			
ITEM	QTY	PART NUMBER	DESCRIPTION
1	1	033-5035-00	4 3/4 Motor Pulley
2	4	018-1075-00	3/8 x 1 1/8 bolt
3	1	042-5020-00	1/4 x 2 Square key Stock
4	2	015-2751-00	Exhaust Gasket
5	1	015-5401-00	Oil drain Valve
6	4	018-8067-00	5/16-18 x 3/4 Socket C/S
7	1	030-0050-00	5/16 Set Screw
8	1	086-0005-00	Ground Cable
9	1	015-2030-00	Kohler-2014 CZT/Outlaw 747cc
10	1	041-5048-00	Pump Belt
11	1	015-0065-00	2014 Kohler Outlaw Muffler
12	1	103-5400-00	Black Boot For Ground Cable
13	4	019-8051-00	5/16" Lock Washer
14	1	019-6029-00	1 1/8" Flat Spacer
15	1	019-8053-00	7/16" Lock Washer
16	1	018-5300-00	7/16" x 2 1/2" Hex Bolt
17	1	070-1000-00	Clutch Assembly
18	1	070-2000-00	Clutch Pigtail
19	1	057-5906-00	PTO Engager Holder
20	2	018-6049-00	3/8" x 1" Hex Bolt
21	2	019-5037-00	3/8" Lock Washer
22	2	013-6014-00	3/8" Hex Nut
23	2	015-8000-00	Spark Plug
24	1	063-6000-00	Universal Inline Fuel Filter
25	1	063-5005-00	747 Kohler Air Filter
26	1	063-5400-00	725 & 747 Kohler Oil Filter



# 824cc EFI Kohler

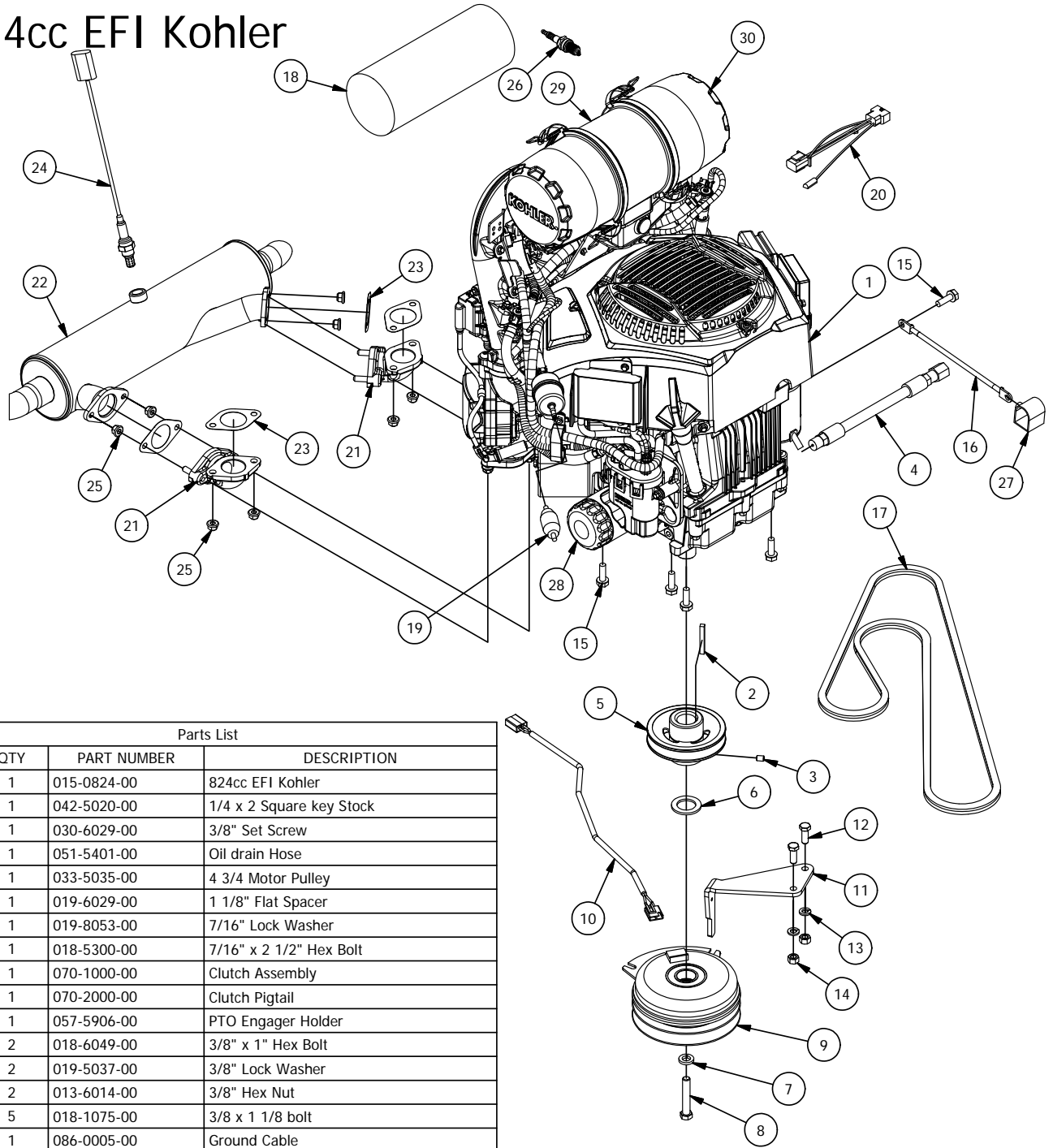

Parts List			
ITEM	QTY	PART NUMBER	DESCRIPTION
1	1	015-0824-00	824cc EFI Kohler
2	1	042-5020-00	1/4 x 2 Square key Stock
3	1	030-6029-00	3/8" Set Screw
4	1	051-5401-00	Oil drain Hose
5	1	033-5035-00	4 3/4 Motor Pulley
6	1	019-6029-00	1 1/8" Flat Spacer
7	1	019-8053-00	7/16" Lock Washer
8	1	018-5300-00	7/16" x 2 1/2" Hex Bolt
9	1	070-1000-00	Clutch Assembly
10	1	070-2000-00	Clutch Pigtail
11	1	057-5906-00	PTO Engager Holder
12	2	018-6049-00	3/8" x 1" Hex Bolt
13	2	019-5037-00	3/8" Lock Washer
14	2	013-6014-00	3/8" Hex Nut
15	5	018-1075-00	3/8 x 1 1/8 bolt
16	1	086-0005-00	Ground Cable
17	1	041-5048-00	Pump Belt
18	1	063-8019-00	Canister Air Filter- Outer
19	1	063-5001-00	25/26 HP Kohler Fuel Filter
20	1	086-9003-00	Harness Adaptor - 824cc EFI Kohler
21	2	031-9040-00	Cast 90 Elbow
22	1	015-0825-00	824cc Kohler Exhaust
23	4	015-9500-00	Exhaust Gasket for 824EFI Kohler
24	1	015-4100-00	O2 Sensor for 824EFI Kohler
25	8	013-1000-00	M8 .125 Mechanical locking Flange Nut
26	4	015-8002-00	Spark Plug - Kohler EFI
27	1	103-5400-00	Black Boot For Ground Cable
28	1	063-5400-00	Oil Filter
29	1	015-2703-00	Kohler Air Canister Complete
30	1	015-2704-00	Kohler End Cap

# 810cc Vanguard

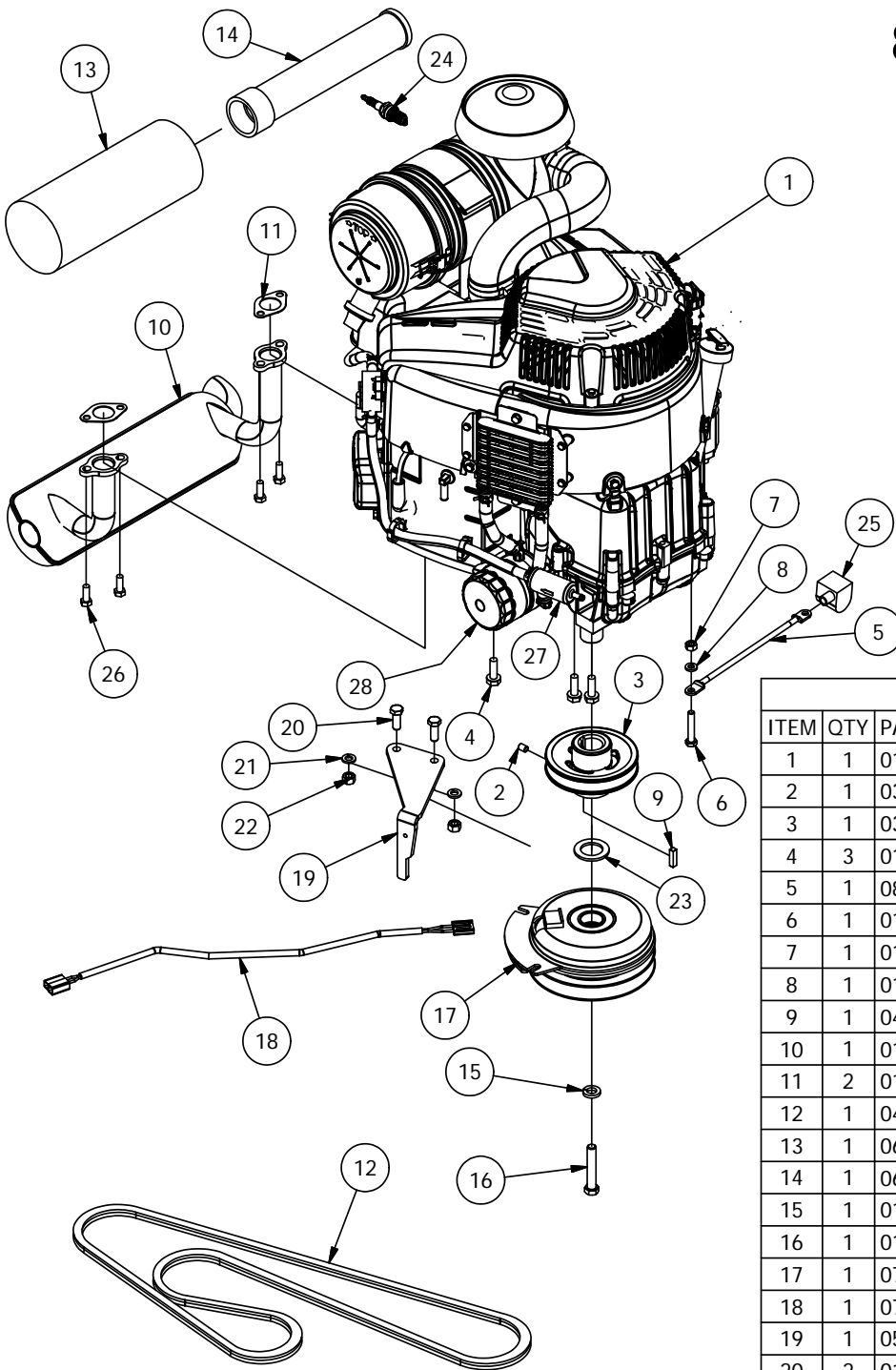

Parts List

ITEM	QTY	PART NUMBER	DESCRIPTION
1	1	015-0810-00	810 Vanguard
2	1	030-6029-00	3/8" Set Screw
3	1	033-5035-00	4 3/4 Motor Pulley
4	3	018-1075-00	3/8 x 1 1/8 bolt
5	1	086-0005-00	Ground Cable
6	1	018-8059-00	5/16" x 1 3/4" Hex Bolt
7	1	013-8043-00	5/16" Nut
8	1	019-8051-00	5/16" Lock Washer
9	1	042-6030-00	1/4" x 1" Key
10	1	015-0027-00	Briggs Exhaust
11	2	015-2709-00	Exhaust Gasket
12	1	041-5048-00	Pump Belt
13	1	063-8019-00	Canister Air Filter- Outer
14	1	063-8020-00	Canister Air Filter- Inner
15	1	019-8053-00	7/16" Lock Washer
16	1	018-5300-00	7/16" x 2 1/2" Hex Bolt
17	1	070-1000-00	Clutch Assembly
18	1	070-2000-00	Clutch Pigtail
19	1	057-5906-00	PTO Engager Holder
20	2	018-6049-00	3/8" x 1" Hex Bolt
21	2	019-5037-00	3/8" Lock Washer
22	2	013-6014-00	3/8" Hex Nut
23	1	019-6029-00	1 1/8" Flat Spacer
24	2	015-8000-00	Spark Plug
25	1	103-5400-00	Black Boot For Ground Cable
26	4	018-0017-00	Torx Bolt-Exhaust
27	1	063-6000-00	Universal Inline Fuel Filter
28	1	063-8018-00	Briggs Oil Filter



# Kawasaki FX 850-V

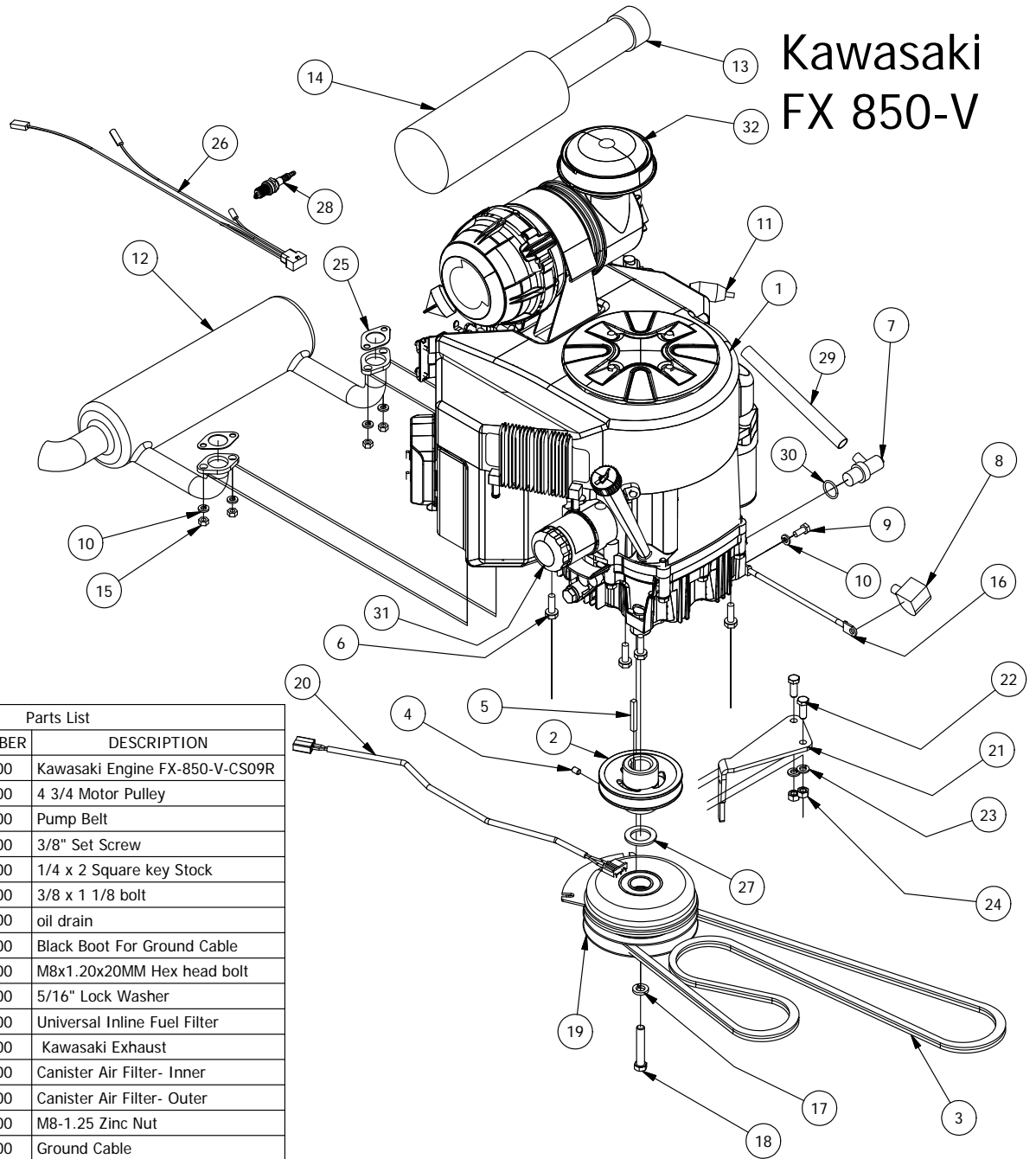

Parts List			
ITEM	QTY	PART NUMBER	DESCRIPTION
1	1	015-0031-00	Kawasaki Engine FX-850-V-CS09R
2	1	033-5035-00	4 3/4 Motor Pulley
3	1	041-5048-00	Pump Belt
4	1	030-6029-00	3/8" Set Screw
5	1	042-5020-00	1/4 x 2 Square key Stock
6	4	018-1075-00	3/8 x 1 1/8 bolt
7	1	015-5404-00	oil drain
8	1	103-5400-00	Black Boot For Ground Cable
9	1	018-5321-00	M8x1.20x20MM Hex head bolt
10	5	019-8051-00	5/16" Lock Washer
11	1	063-6000-00	Universal Inline Fuel Filter
12	1	015-0035-00	Kawasaki Exhaust
13	1	063-8020-00	Canister Air Filter- Inner
14	1	063-8019-00	Canister Air Filter- Outer
15	4	013-0075-00	M8-1.25 Zinc Nut
16	1	086-0005-00	Ground Cable
17	1	019-8053-00	7/16" Lock Washer
18	1	018-5300-00	7/16" x 2 1/2" Hex Bolt
19	1	070-1000-00	Clutch Assembly
20	1	070-2000-00	Clutch Pigtail
21	1	057-5906-00	PTO Engager Holder
22	2	018-6049-00	3/8" x 1" Hex Bolt
23	2	019-5037-00	3/8" Lock Washer
24	2	013-6014-00	3/8" Hex Nut
25	2	015-2709-00	Exhaust Gasket
26	1	086-9002-00	Harness Adaptor
27	1	019-6029-00	1 1/8" Flat Spacer
28	2	015-8001-00	Spark Plug - Kawasaki
29	1	051-8064-00	Oil Drain Hose
30	1	015-5403-00	O-Ring
31	1	063-8017-00	Kawasaki Oil Filter
32	1	088-1071-00	Kawasaki Rain Cap

# 993cc Vanguard

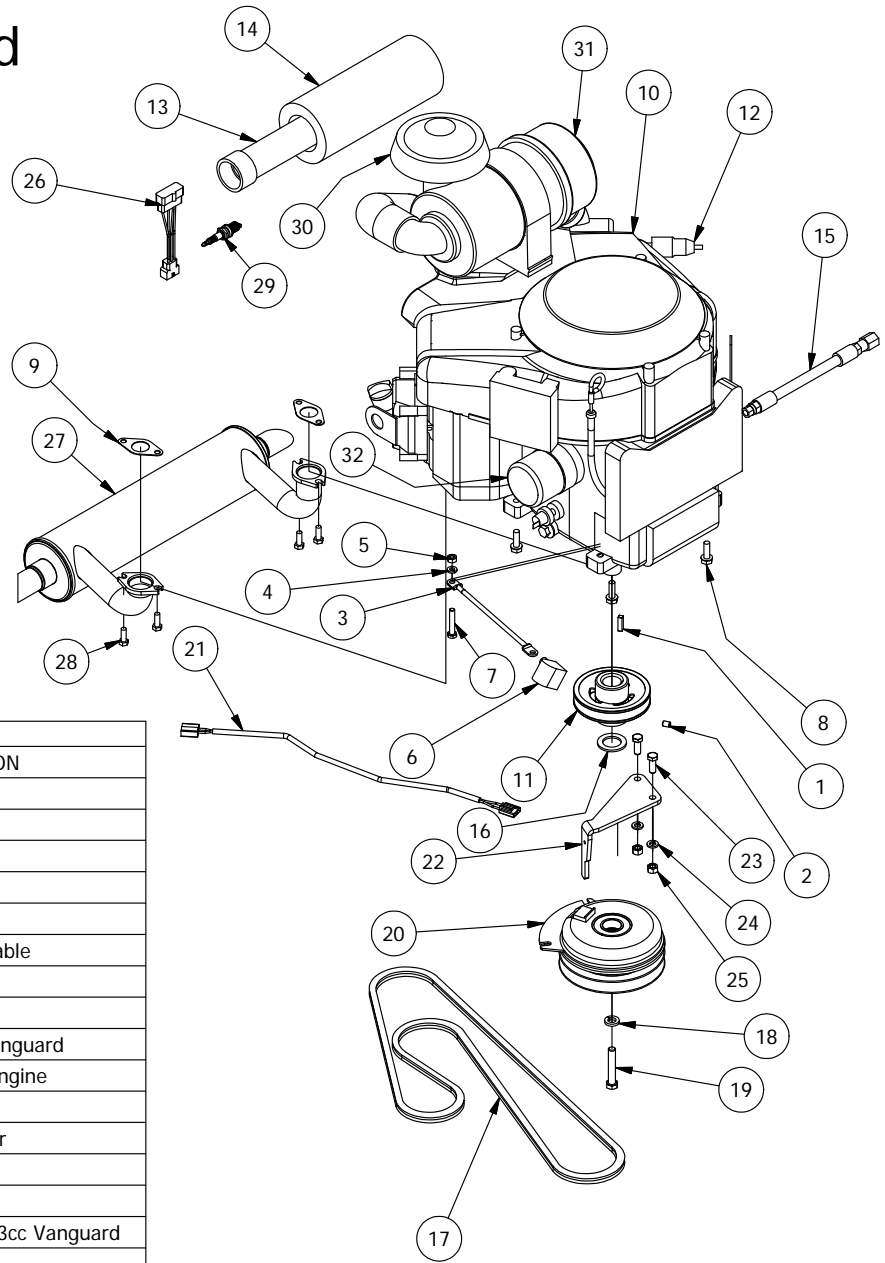

993cc Vanguard			
ITEM	QTY	PART NUMBER	DESCRIPTION
1	1	042-6030-00	1/4" x 1" Key
2	1	030-0050-00	5/16 Set Screw
3	1	086-0005-00	Ground Cable
4	1	019-8051-00	5/16" Lock Washer
5	1	013-8043-00	5/16" Nut
6	1	103-5400-00	Black Boot For Ground Cable
7	1	018-8059-00	5/16" x 1 3/4" Hex Bolt
8	3	018-1075-00	3/8 x 1 1/8 bolt
9	2	015-0025-00	Exhaust Gasket for 23 Vanguard
10	1	015-3600-00	993cc Briggs Vanguard Engine
11	1	033-5035-00	4 3/4 Motor Pulley
12	1	063-6000-00	Universal Inline Fuel Filter
13	1	063-8020-00	Canister Air Filter- Inner
14	1	063-8019-00	Canister Air Filter- Outer
15	1	051-5402-00	14 mm Oil drain Hose 993cc Vanguard
16	1	019-6029-00	1 1/8" Flat Spacer
17	1	041-5048-00	Pump Belt
18	1	019-8053-00	7/16" Lock Washer
19	1	018-5300-00	7/16" x 2 1/2" Hex Bolt
20	1	070-1000-00	Clutch Assembly
21	1	070-2000-00	Clutch Pigtail
22	1	057-5906-00	PTO Engager Holder
23	2	018-6049-00	3/8" x 1" Hex Bolt
24	2	019-5037-00	3/8" Lock Washer
25	2	013-6014-00	3/8" Hex Nut
26	1	086-9001-00	Harness Adaptor - 933cc Vanguard
27	1	015-0049-00	2015 Exhaust - 36hp Vanguard
28	4	018-0017-00	Torx Bolt-Exhaust
29	2	015-8000-00	Spark Plug
30	1	063-2045-00	Rain Cap Fits all Canisters
31	1	015-2705-00	Complete Canister
32	1	063-8018-00	Briggs Oil Filter



# Outlaw 54" Deck

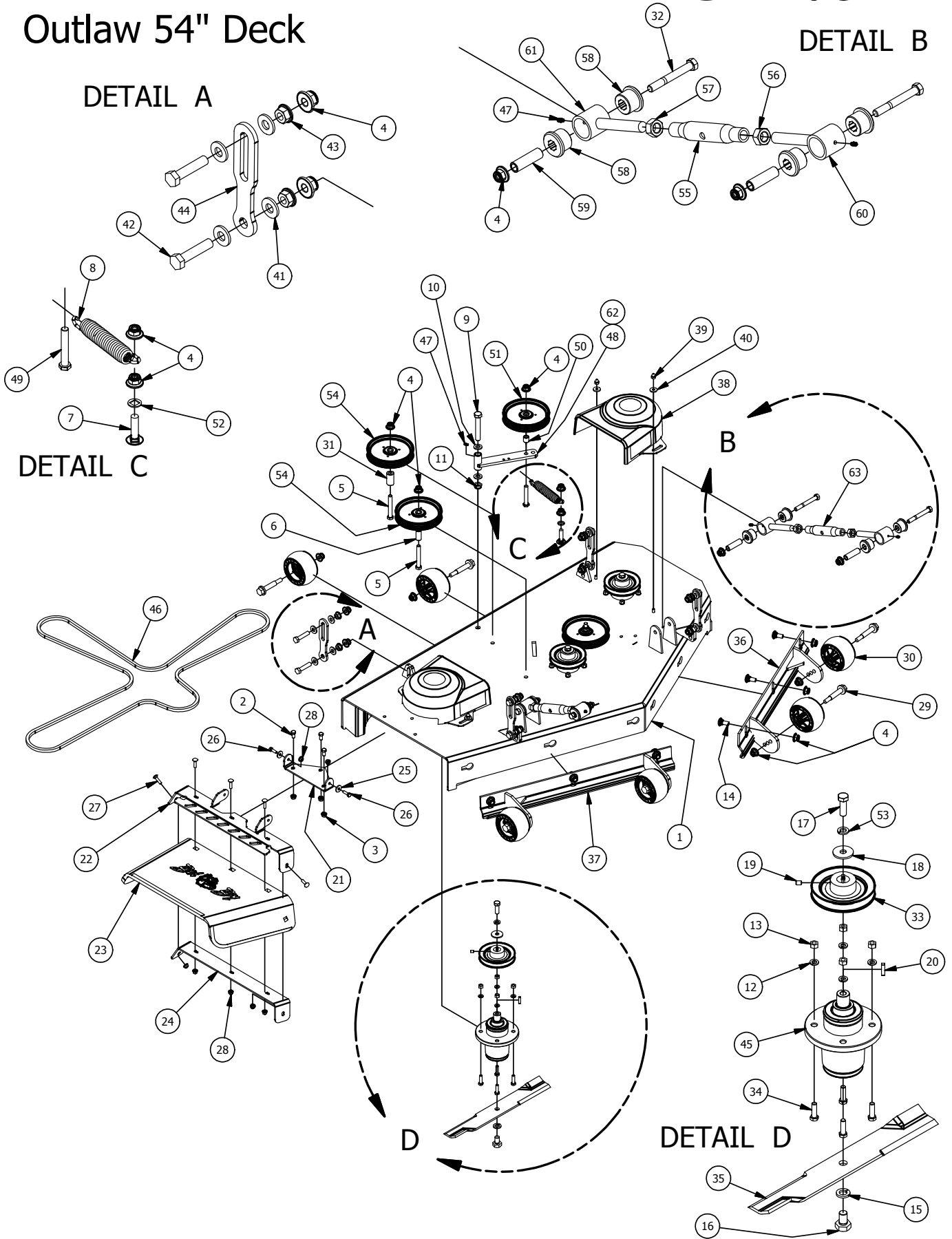

Parts List			
ITEM	QTY	PART NUMBER	DESCRIPTION
1	1	060-5550-00	2015 54" Deck
2	3	018-5250-00	3/8" x 3/4" Hex Bolt
3	3	013-5201-00	3/8" Flange Nut
4	30	013-8050-00	1/2-13 Nylon Flange Nut
5	3	018-2018-00	1/2 x 3 1/2 Flange Bolt Grade 8
6	2	025-5338-00	.502 ID X .750 OD X 1.500 Long Spacer
7	1	018-1050-00	1/2 x 2" Carriage Bolt
8	1	034-2020-00	2015 Deck Idler Spring Outlaws
9	1	018-5311-00	5/8" x 4" Hex Bolt
10	2	019-6017-00	.630 ID Plastic Washer
11	1	013-5301-00	5/8-11 Nylon Insert Jam Half Nut
12	12	019-5037-00	3/8 Lockwasher Zinc
13	12	013-6014-00	3/8-16 Hex Nuts Zinc
14	6	018-3003-00	1/2" x 1 1/4" Carriage Bolt
15	3	019-4807-00	5/8" Lock Washer
16	3	018-6020-00	5/8" x 1 1/2" Grade 8 Hex Bolt (Fine)
17	3	018-6019-00	1/2"-20 x 1 1/2 - Grade 5 Fine Thread Bolt
18	3	019-6020-00	1/2 Belleville Washer
19	3	030-0050-00	5/16 Set Screw
20	3	042-6030-00	1/4" x 1" Key
21	1	206-6017-00	Discharge Chute Hanger (deck mounted)
22	1	039-4864-00	60" Discharge Chute Upper Hanger
23	1	210-6005-00	Rubber Discharge Chute
24	1	039-4863-00	60" Discharge Lower Bracket
25	2	019-6042-00	.360 ID Plastic Washer
26	2	018-2007-00	5/16" x 1" Bolt
27	5	018-4703-00	5/16" x 1 1/4" Carriage Bolt
28	7	013-8049-00	5/16" Nylock Flange Nut Zinc
29	6	018-0010-00	Deck Wheel Bolt
30	6	022-1000-00	Anti-Scalp Rollers
31	1	025-5339-00	1 3/4" Pulley Spacer
32	4	018-5019-00	1/2" x 4" Bolt (Grade 8)
33	3	033-6003-00	5" Spindle Deck Pulley
34	12	018-5040-00	3/8" x 1 1/4" Hex Bolt
35	3	038-0001-00	54" Deck Fusion Blade For Outlaw
36	1	060-5520-00	54 Deck Adustable Front (Left)
37	1	060-5530-00	54 Deck Adustable Front (Right)
38	2	014-5000-00	Pulley Cover
39	4	013-0004-00	Acorn nut-pulley Cover
40	4	019-6050-00	.360 ID Plastic Washer-Black
41	16	019-8054-00	.505 Nylon Spacer
42	8	018-6037-00	1/2-13X 2-1/4 GR Hex Bolts
43	8	013-5300-00	1/2" Flange Nut
44	4	039-2125-00	Deck_Hanging_Tab
45	3	037-4000-50	OUTLAW SPINDLE ASSEMBLY
46	1	041-1650-00	60" ZT Deck Belt
47	5	024-6034-00	1/4" Press in Grease Fitting
48	1	039-6945-00	Deck Idler
49	1	018-7016-00	1/2-13 x GR 5 Hex Bolt Zinc
50	1	025-5203-00	Spacer 3/4 OD x 1/2 ID x 3\4 Length
51	1	033-7201-00	5-3/4 Idler Pulley-Don Dye
52	1	019-0007-00	.517 Square Hole Round Washer
53	3	019-5007-00	1/2" Lock Washer
54	3	033-7201-25	5-3/4 Idler Pulley-Capitol Stampings
55	2	048-7020-00	2015 Outlaw Toplink Body
56	2	013-0008-00	3/4-10 Left-Handed Hex Nuts Zinc
57	2	013-0007-00	3/4-10 Hex Nuts Zinc
58	8	032-2000-00	Bushing
59	4	032-2001-00	Sleeve
60	2	048-7022-00	Turn Left-Handed
61	2	048-7021-00	Right-Handed End
62	1	039-6945-98	Deck Idler Assembly - Includes parts: 4,47,48,50,51
63	2	048-7000-00	Turnbuckle Assembly





# Outlaw 61" Deck

DETAIL A

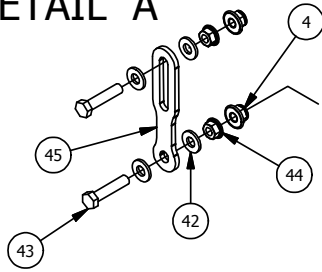

DETAIL B

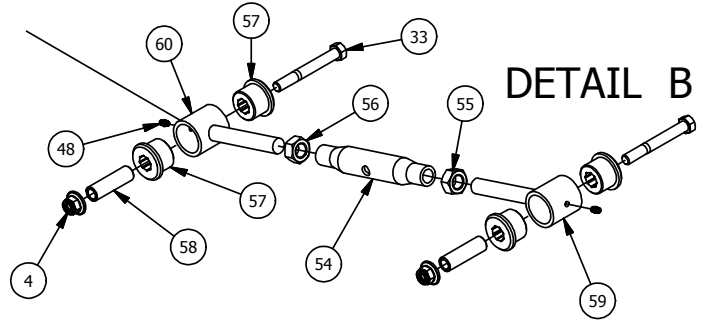

DETAIL C

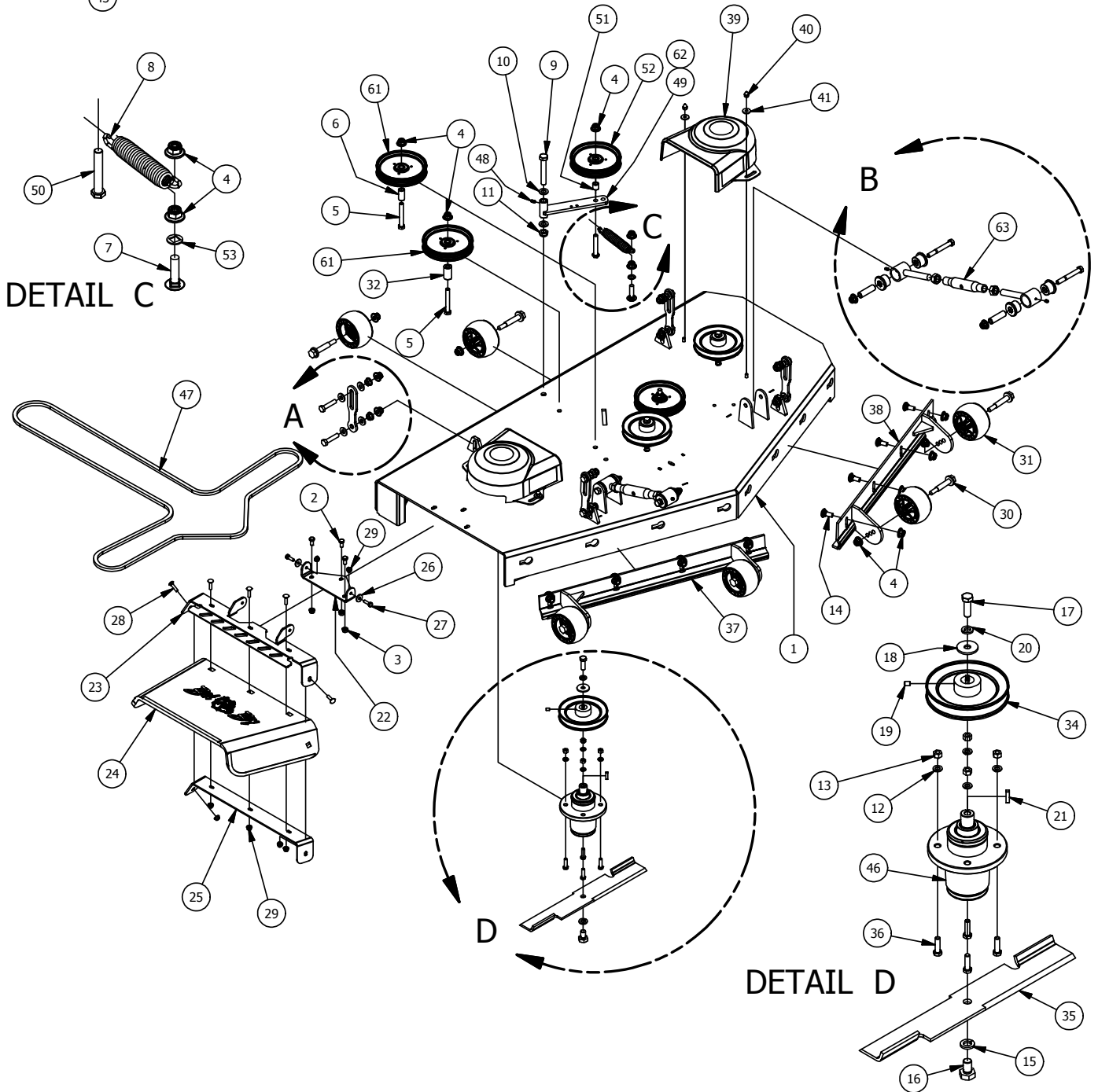
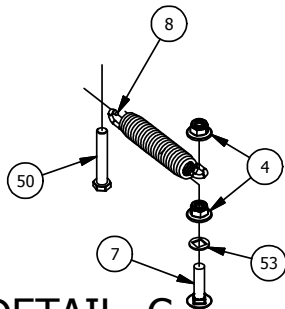

DETAIL D

Parts List			
ITEM	QTY	PART NUMBER	DESCRIPTION
1	1	060-6150-00	2015 61" Deck
2	3	018-5250-00	3/8" x 3/4" Hex Bolt
3	3	013-5201-00	3/8" Flange Nut
4	32	013-8050-00	1/2-13 Nylon Flange Nut
5	3	018-2018-00	1/2 x 3 1/2 Flange Bolt Grade 8
6	2	025-5338-00	.502 ID X .750 OD X 1.500 Long Spacer
7	1	018-1050-00	1/2 x 2" Carriage Bolt
8	1	034-2020-00	2015 Deck Idler Spring Outlaws
9	1	018-5311-00	5/8" x 4" Hex Bolt
10	2	019-6017-00	.630 ID Plastic Washer
11	1	013-5301-00	5/8-11 Nylon Insert Jam Half Nut
12	12	019-5037-00	3/8 Lockwasher Zinc
13	12	013-6014-00	3/8-16 Hex Nuts Zinc
14	8	018-3003-00	1/2" x 1 1/4 Carriage Bolt
15	3	019-4807-00	5/8" Lock Washer
16	3	018-6020-00	5/8" x 1 1/2" Grade 8 Hex Bolt (Fine)
17	3	018-6019-00	1/2"-20 x 1 1/2 - Grade 5 Fine Thread Bolt
18	3	019-6020-00	1/2 Belleville Washer
19	3	030-0050-00	5/16 Set Screw
20	3	019-5007-00	1/2" Lock Washer
21	3	042-6030-00	1/4" x 1" Key
22	1	206-6017-00	Discharge Chute Hanger (deck mounted)
23	1	039-4864-00	60" Discharge Chute Upper Hanger
24	1	210-6005-00	Rubber Discharge Chute
25	1	039-4863-00	60" Discharge Lower Bracket
26	2	019-6042-00	.360 ID Plastic Washer
27	2	018-2007-00	5/16" x 1" Bolt
28	5	018-4703-00	5/16" x 1 1/4" Carriage Bolt
29	7	013-8049-00	5/16" Nylock Flange Nut Zinc
30	6	018-0010-00	Deck Wheel Bolt
31	6	022-1000-00	Anti-Scalp Rollers
32	1	025-5339-00	1 3/4" Pulley Spacer
33	4	018-5019-00	1/2" x 4" Bolt (Grade 8)
34	3	033-6004-00	6 1/4" Drive Pulley
35	3	038-6080-00	61 inch Fusion Blade
36	12	018-5040-00	3/8" x 1 1/4" Hex Bolt
37	1	060-6220-00	61 Deck Adustable Front (Right)
38	1	060-6210-00	61 Deck Adustable Front (Left)
39	2	014-5000-00	Pulley Cover
40	4	013-0004-00	Acorn nut-pulley Cover
41	4	019-6050-00	.360 ID Plastic Washer-Black
42	16	019-8054-00	.505 Nylon Spacer
43	8	018-6037-00	1/2-13X 2-1/4 GR Hex Bolts
44	8	013-5300-00	1/2" Flange Nut
45	4	039-2125-00	Deck_Hanging_Tab
46	3	037-4000-50	OUTLAW SPINDLE ASSEMBLY
47	1	041-0178-00	B178 Belt For 61 Inch Outlaw
48	5	024-6034-00	1/4" Press in Grease Fitting
49	1	039-6945-00	Deck Idler
50	1	018-7016-00	1/2-13 x GR 5 Hex Bolt Zinc
51	1	025-5203-00	Spacer 3/4 OD x 1/2 ID x 3\4 Length
52	1	033-7201-00	5-3/4 Idler Pulley-Don Dye
53	1	019-0007-00	.517 Square Hole Round Washer
54	2	048-7020-00	2015 Outlaw Toplink Body
55	2	013-0008-00	3/4-10 Left-Handed Hex Nuts Zinc
56	2	013-0007-00	3/4-10 Hex Nuts Zinc
57	8	032-2000-00	Bushing
58	4	032-2001-00	Sleeve
59	2	048-7022-00	Turn Left-Handed
60	2	048-7021-00	Right-Handed End
61	3	033-7201-25	5-3/4 Idler Pulley-Capitol Stampings
62	1	039-6945-98	Deck Idler Assembly - Includes parts: 4,48,49,50,51
63	2	048-7000-00	Turnbuckle Assembly



# Outlaw 72" Deck

DETAIL A

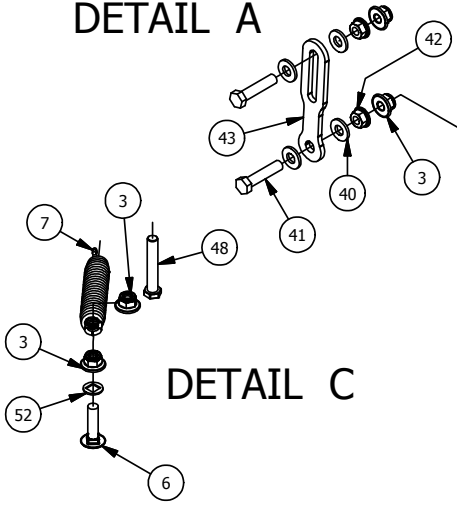

DETAIL B

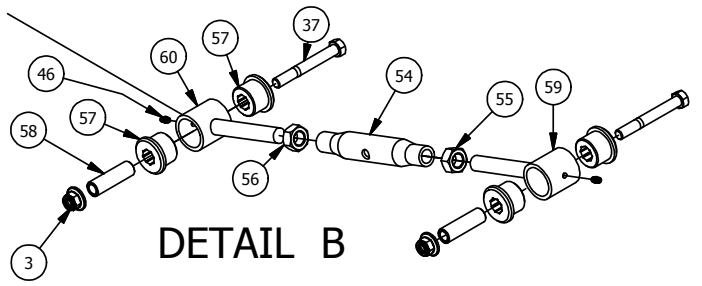

DETAIL C

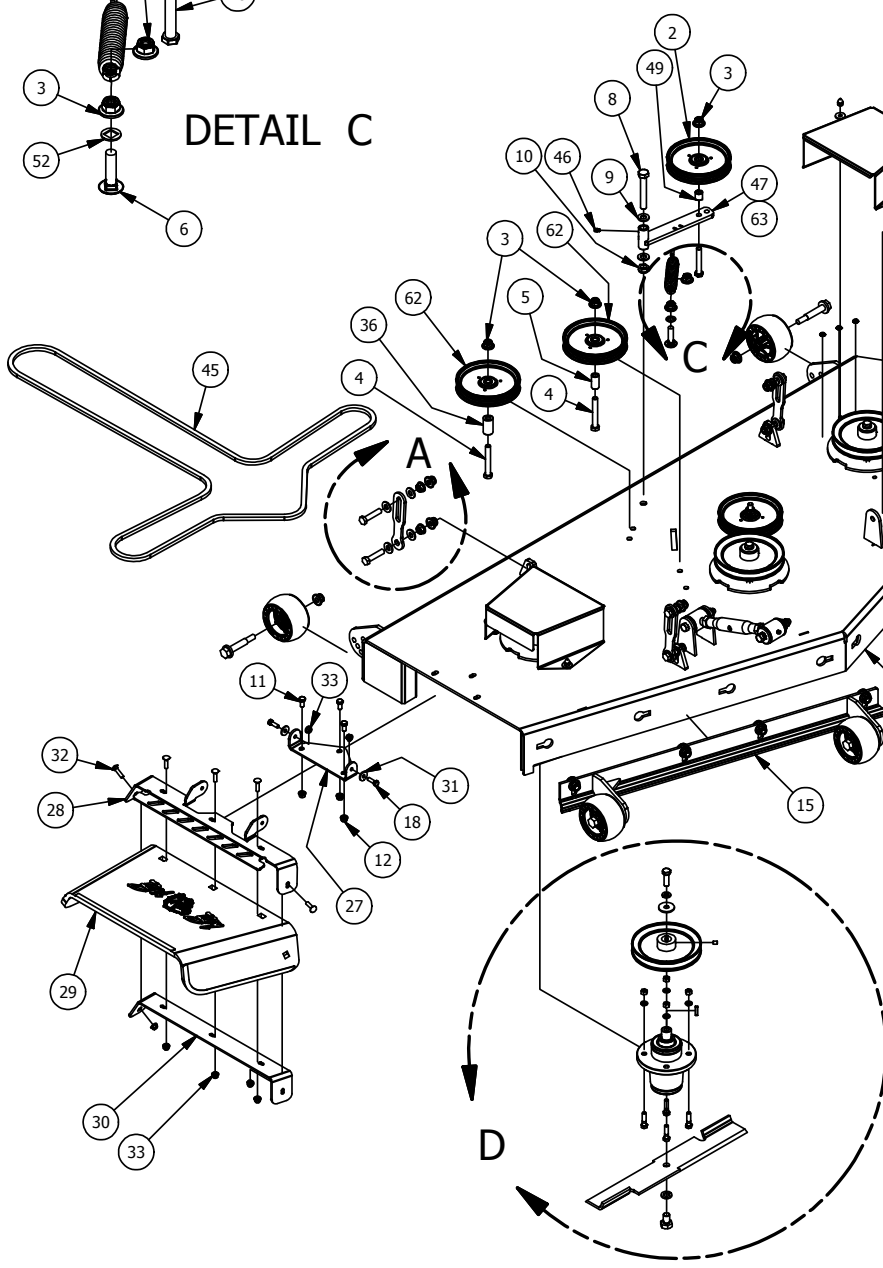

DETAIL D

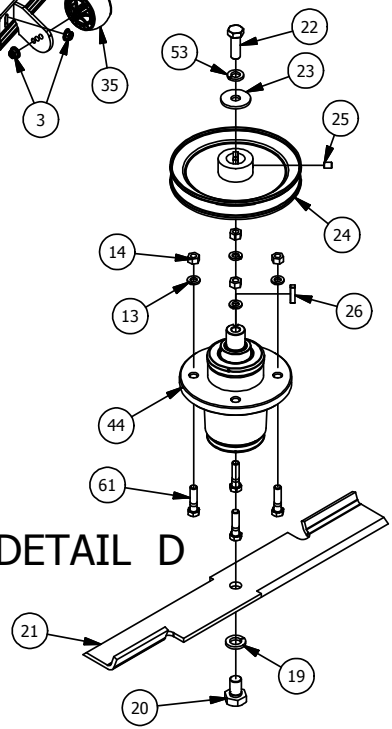

Parts List			
ITEM	QTY	PART NUMBER	DESCRIPTION
1	1	060-7250-00	2015 72" Deck
2	1	033-7201-00	5-3/4 Idler Pulley-Don Dye
3	32	013-8050-00	1/2-13 Nylon Flange Nut
4	3	018-2018-00	1/2 x 3 1/2 Flange Bolt Grade 8
5	2	025-5338-00	.502 ID X .750 OD X 1.500 Long Spacer
6	1	018-1050-00	1/2 x 2" Carriage Bolt
7	1	034-2020-00	2015 Deck Idler Spring Outlaws
8	1	018-5311-00	5/8" x 4" Hex Bolt
9	2	019-6017-00	.630 ID Plastic Washer
10	1	013-5301-00	5/8-11 Nylon Insert Jam Half Nut
11	3	018-5250-00	3/8" x 3/4" Hex Bolt
12	3	013-5201-00	3/8" Flange Nut
13	12	019-5037-00	3/8 Lockwasher Zinc
14	12	013-6014-00	3/8-16 Hex Nuts Zinc
15	1	060-7211-00	72" Deck Adjustable Front (Right)
16	1	060-7210-00	72" Deck Adjustable Front (Left)
17	8	018-3003-00	1/2" x 1 1/4 Carriage Bolt
18	2	018-2007-00	5/16" x 1" Bolt
19	3	019-4807-00	5/8" Lock Washer
20	3	018-6020-00	5/8" x 1 1/2" Grade 8 Hex Bolt (Fine)
21	3	038-7230-00	72" High Lift Fusion Blade
22	3	018-6019-00	1/2"-20 x 1 1/2 - Grade 5 Fine Thread Bolt
23	3	019-6020-00	1/2 Belleville Washer
24	3	033-7203-00	7" Deck Pulley
25	3	030-0050-00	5/16 Set Screw
26	3	042-6030-00	1/4" x 1" Key
27	1	206-6017-00	Discharge Chute Hanger (deck mounted)
28	1	039-4864-00	60" Discharge Chute Upper Hanger
29	1	210-6005-00	Rubber Discharge Chute
30	1	039-4863-00	60" Discharge Lower Bracket
31	2	019-6042-00	.360 ID Plastic Washer
32	5	018-4703-00	5/16" x 1 1/4" Carriage Bolt
33	7	013-8049-00	5/16" Nylock Flange Nut Zinc
34	6	018-0010-00	Deck Wheel Bolt
35	6	022-1000-00	Anti-Scalp Rollers
36	1	025-5339-00	1 3/4" Pulley Spacer
37	4	018-5019-00	1/2" x 4" Bolt (Grade 8)
38	4	013-0004-00	Acorn nut-pulley Cover
39	4	019-6050-00	.360 ID Plastic Washer-Black
40	16	019-8054-00	.505 Nylon Spacer
41	8	018-6037-00	1/2-13X 2-1/4 GR Hex Bolts
42	8	013-5300-00	1/2" Flange Nut
43	4	039-2125-00	Deck_Hanging_Tab
44	3	037-4000-50	OUTLAW SPINDLE ASSEMBLY
45	1	041-0202-00	B202 Belt for 72" Outlaw
46	5	024-6034-00	1/4" Press in Grease Fitting
47	1	039-6945-00	Deck Idler
48	1	018-7016-00	1/2-13 x GR 5 Hex Bolt Zinc
49	1	025-5203-00	Spacer 3/4 OD x 1/2 ID x 3\4 Length
50	2	014-7204-00	72 Spindle Cover
51	12	058-6000-00	Black, Round Stick-On Rubber Bumpon
52	1	019-0007-00	.517 Square Hole Round Washer
53	3	019-5007-00	1/2" Lock Washer
54	2	048-7020-00	2015 Outlaw Toplink Body
55	2	013-0008-00	3/4-10 Left-Handed Hex Nuts Zinc
56	2	013-0007-00	3/4-10 Hex Nuts Zinc
57	8	032-2000-00	Bushing
58	4	032-2001-00	Sleeve
59	2	048-7022-00	Turn Left-Handed
60	2	048-7021-00	Right-Handed End
61	12	018-6012-00	3/8" x 1 1/2" Hex Bolt
62	3	033-7201-25	5-3/4 Idler Pulley-Capitol Stampings
63	1	039-6945-98	Deck Idler Assembly - Includes parts: 2,3,47,48,49
64	2	048-7000-00	Turnbuckle Assembly



## 037-4000-50 Double Bearing Spindle

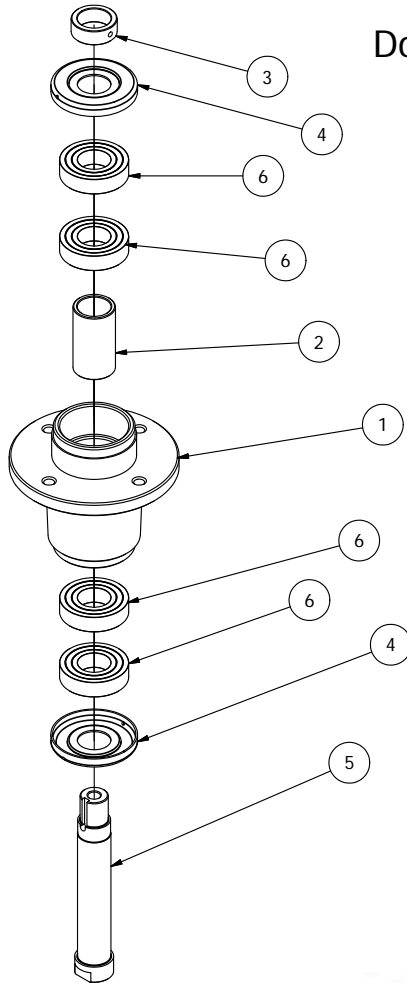

Parts List			
ITEM	QTY	PART NUMBER	DESCRIPTION
1	1	037-4001-00	4000 Series Spindle Housing
2	1	037-4002-00	4000 Series Spindle Spacer
3	1	037-9050-00	Locking Collar w/ 1/4"-20 Set Screw
4	2	037-8002-00	Spindle Dust Cap
5	1	037-6026-00	ZT-AOS Spindle Shaft
6	4	037-6023-00	Bearing - 6206



091-1111-00  
726cc Decal



091-1108-00  
747cc Decal



091-1110-00  
810cc Decal



091-1113-00  
824cc Decal



091-0904-00  
54" Decal



091-1152-00  
2015 Outlaw Control Panel Decal



091-3017-00  
Pump Belt Route Decal



091-1109-00  
852cc Decal



091-0917-00  
61" Decal



091-1102-00 Left Steering Control Decal  
091-1109-00 Right Steering Control Decal



091-3309-00  
Deck Belt Route Decal



091-1112-00  
993cc Decal



091-0918-00  
72" Decal



091-1104-00  
Throttle Decal

091-3012-00  
Danger Decal - Spindle/Discharge

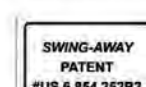

SWING-AWAY PATENT  
#US 6,854,252B2



091-1105-00  
Outlaw Deck Height Decal



091-0919-00  
ArmorTek Decal

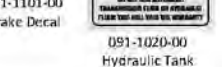

091-1101-00  
Brake Decal

091-1020-00  
Hydraulic Tank

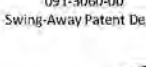

091-3060-00  
Swing-Away Patent Decal



091-3150-00  
Outlaw Warning Decal



091-0902-00  
Logo Decal-Floorboard

---

# 2016 LIMITED WARRANTY

## FOR

### BAD BOY COMMERCIAL MOWER

#### ( STAND ON, DIESEL, OUTLAW, OUTLAW EXTREME, and OUTLAWXP)

#### 1. WHAT THIS WARRANTY COVERS, AND FOR HOW LONG:

Bad Boy, Inc. will, at its option, repair or replace, without charge, any part covered by the warranty which is found to be defective in material and/or workmanship within two (2) years\* after date of sale to the original retail purchaser **unless the product is used for rental purposes, in which case this warranty is limited to ninety (90) days.**

The leading edge of the deck shell will be warranted for the entire lifetime of the machine to the original purchaser against defects in materials and workmanship. Labor required to repair or replace the leading edge of the deck shell will be covered by Bad Boy Inc. for two years and at the unit owner's expense during the balance of the lifetime of the machine.

Belts are warranted for a period of ninety (90) days against materials or workmanship defects.

Seats are warranted for a period of (6) months against material or workmanship defects.

At Bad Boy, Inc.'s request, customer will make the defective part available for inspection by Bad Boy, Inc. and/or return the defective part to Bad Boy, Inc., **transportation charges prepaid.**

#### 2. WHAT THIS WARRANTY DOES NOT COVER:

- A. This warranty does not cover defects caused by depreciation or damage caused by normal wear, accidents, improper maintenance, improper use or abuse of the product, alterations, or failure to follow the instruction contained in the Owner's Manual for operation and maintenance.
- B. The customer shall pay any charges for making service calls and/or for transporting the mower to and from the place where the inspection and/or warranty work is performed.  
**Bad Boy Inc. will not be responsible for the pickup and delivery of a machine for warranty purposes.**
- C. Engines are warranted separately by their respective manufacturer. The available warranties covering this item are furnished with each mower. Bad Boy, Inc. does not assume any warranty obligation, liability or modification for this item, which is covered exclusively by the stated warranty of the respective manufacturers.
- D. Tires, blades, deck anti-scalping wheels, and dust covers are considered to be consumable wear items and are therefore not warranted.
- E. Batteries are warranted for six months (free replacement) from the retail purchase date against materials or workmanship defects. The battery warranty must be obtained through the battery manufacturer.
- F. Normal maintenance services such as oil change, cleaning, lubrication, adjustment.
- G. Replacement of services, items, such as oil, lubricants, spark plugs, belts, rubber hoses or other items subject to normal service replacement.

#### 3. HOW TO OBTAIN SERVICE UNDER THIS WARRANTY:

- A. Warranty service can be arranged by contacting the dealer where you purchased the mower. Proof of the date of purchase may be required to verify warranty coverage.

<b>B. Warranty claims will not be reviewed or paid unless the warranty registration is received by Bad Boy, Inc. within 30 days of the retail purchase date.</b>
--

- C. Warranty claims requiring parts returned will be settled upon return of parts to Bad Boy for inspection.
- D. All warranty issues must be handled through an authorized service center or dealership.

#### 4. WARRANTY LIMITATION:

- A. **THERE IS NO OTHER EXPRESS WARRANTY. ANY WARRANTY THAT MAY BE IMPLIED FROM THIS PURCHASE INCLUDING MERCHANTABILITY AND FITNESS FOR A PARTICULAR PURPOSE IS HEREBY LIMITED TO THE DURATION OF THIS WARRANTY AND TO THE EXTENT PERMITTED BY LAW ANY AND ALL IMPLIED WARRANTIES ARE EXCLUDED.** Some states do not allow limitations on how long an implied warranty lasts, so the above limitations may not apply to you.
- B. **BAD BOY, INC. WILL NOT BE LIABLE FOR ANY INCIDENTAL, CONSEQUENTIAL, OR SPECIAL DAMAGES AND/OR EXPENSES IN CONNECTION WITH THE PURCHASE OR USE OF THE MOWER.** Some states do not allow the exclusion or limitation of incidental or consequential damages, so the above limitation(s) or exclusion(s) may not apply to you.
- C. Only the warranty expressed in this limited warranty shall apply and no dealer, distributor, or individual is authorized to amend, modify, or extend this warranty in any way. Accordingly, additional statements such as dealer advertising or presentations, whether oral or written, do not constitute warranties by Bad boy, Inc., and should not be relied on.
- D. This warranty extends only to turf equipment operated under normal conditions and properly serviced and maintained. The warranty expressly does not cover (i) any defects, damage or deterioration due to normal use, wear and tear, or exposure; (ii) normal maintenance services such as oil change, cleaning, lubrication, adjustment; (iii) replacement of services, items, such as oil, lubricants, spark plugs, belts, rubber hoses or other items subject to normal service replacement; (iv) damage or defects arising out of or relating to misuse, neglect, alteration, negligence or accident; (v) repair or replacement arising from operation of or use of the turf equipment which is not in accordance with operating instructions as specified in the operator's manual or other operational instructions provided by Bad Boy Inc.; (vi) repair or replacement arising as a result of any operation from turf equipment that has been altered or modified so as to, indetermination of Bad Boy, Inc., adversely affect the operation, performance or durability of the equipment or that has altered, modified or affected the turf equipment so as to change the intended use of the product; (vii) repair or replacement necessitated by use of parts, accessories or supplies, including gasoline, oil or lubricants, incompatible with the turf equipment or other than as recommended in the operator's manual or other operational instructions provided by Bad Boy, Inc.; (viii) repairs or replacements resulting from parts or accessories which have adversely affected the operation, performance or durability of the turf equipment; or (ix) damage or defects due to or arising out of repair of turf equipment by person or persons other than an authorized Bad Boy, Inc., service dealer or the installation of parts other than genuine Bad Boy, Inc., recommended parts.  
**As a condition to this warranty, customer shall have read the operator's manual and ensured the mower has been registered within 30 days of purchase.**
- E. This warranty gives you specific legal rights, and you may also have other rights, which vary from state to state.



---

**Bad Boy, Inc.**  
**102 Industrial Drive**  
**Batesville, AR 72501**  
**www.badboymowers.com**

**Technical Support:** .....techsupport@badboymowers.com

**Warranty:** .....warranty@badboymowers.com

**Parts:** .....partsdept@badboymowers.com

## **WARRANTY REGISTRATION**

**Ensure selling dealership has registered mower within  
30 days of purchase to validate warranty.**

Please record your serial number, date of purchase and dealership information  
for your records.

Serial # \_\_\_\_\_

Date of Purchase \_\_\_\_\_

Dealer Information \_\_\_\_\_



For additional information, please see us at

**[www.badboymowers.com](http://www.badboymowers.com)**

Bad Boy, Inc.  
102 Industrial Drive  
Batesville, Arkansas 72501